

OCULUS Searcher

Rugged pan/tilt unit with dual HD/SD video and thermal modules

The Oculus Searcher is the perfect solution for mid-range surveillance applications, providing the best performance available within a rugged pan and tilt casing of this size.

The Oculus Searcher employs DRS' proven un-cooled high resolution 640 x 480 (DB), 17µm VOx thermal imaging technologies to provide man detection up to 2.1 kilometres. The thermal uses ICE to enhance contrast and features continuous digital zoom. All models also offer simultaneous video verification provided by a 36x zoom module or 30x HD zoom module.

As with all Oculus units, everything is fully housed within a hard anodised aluminium casing, fully rated to IP67 and ready to handle the harshest environments. The toughened, optically flat glass provides clear images, even at the highest zoom levels and can be kept clean at all times by the compact wiper unit. Optical encoders for both the pan and tilt axes provide highly accurate positioning and repeatability, allied with self-correction systems that will counteract any external interference with the moving head.

The Oculus Searcher can be mounted upright or inverted and the yoke can be offset to eliminate blindspots through a full 360 degrees of rotation. Mounting accessories are available to suit standard mounting platforms, including 4" PCD.

Key features

- HD and SD video option
- ICE - Image enhancement technology
- Industry leading 17µm thermal technology
- Simultaneous video and thermal outputs
- Man detection up to 2.1km
- IP and HD-SDI option
- Optical encoders for accurate positioning and repeatability
- Protected to IP67 (IP68 option)
- 316L Stainless steel option
- Built-in camera lens wiper as standard
- Preset, tours and privacy masking
- Multiple mounting options
- Optional heater for reliable operation down to -40°C



Tamarisk® Image enhancement selections

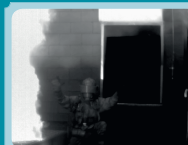

AGC

Firefighter is visible with minimal contrast. Background of scene is washed out and nothing is visible through the window.

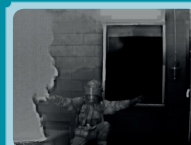

ICE Low

Firefighter and background are clearly visible with added contrast and edge enhancement. No visibility through the window.



ICE High

Maximum edge enhancement brings out details of firefighter and reveals elements in the distant background through the window.

AGC

Automatic Gain Control adjusts the image gain to the optimal range.

ICE Low

Provides moderate levels of contrast and edge enhancement.

ICE High

Additional local area contrast and edge enhancement to enrich background and foreground content.

The Silent Sentinel Range

Silent Sentinel offer an extensive range of camera and lens configurations to meet your exact surveillance requirements.

Contact customer service for more information on our full range of products and bespoke design and build services.

Tel: + 44 (0)1992 558 093

www.silentsentinel.com



OCULUS



AERON



OSIRIS



JAEGAR

OCULUS

Oculus standard and HD video range

Video type	SD	HD
Optical zoom	36x	36x
Digital Enlargement	12x (432x combined)	12x (360x with optical zoom)
Image Sensors	1/4" Exview CCD	1/2.8" type Exmor CMOS sensor
Resolution	530TVL	Approx 3.27 million
Signal System	PAL	HD: 1080p/SD:NTSC/PAL
Lens (wide to tele)	F=4.3mm to 122mm F1.6 to F4.5	f=4.3mm to 129.0mm, F1.6 to F4.7
Angle of view - horizontal	58.° (W) to 1.7° (T)	54.1° (W) to 2.9° (T)
Minimum illumination (SOIRE)	1.4 lux Colour, 0.01 lux Mono	1.7 lux, 0.5 lux in High Sens Mode
Video output	Composite	Digital/IP

Oculus thermal range

Video type	Thermal
Sensor type	Uncooled Vix Microbolometer
Pixel size	17µ
Spectral band	8-14µm
Thermal sensitivity	<50mK
Array format	640x480
Frames rates	9Hz, 25Hz
Image control	White hot, Black hot, Invert
Focus	Fixed, preset, Althermalised
Zoom	E-zoom 1-4, Region of interest
FOV	12° - 50mm f1.2
Video Output	Composite

Mechanical specifications

Construction	Die-cast hard anodised, powder coated aluminium with A4 stainless fittings	
Turning diameter	Normal 220mm / 8.66"	Offset 370mm / 14.57"
Height	370mm / 14.57"	340mm / 13.38"
Height with adaptor	500mm / 19.68"	470mm / 18.50"
Pan rotation limit / speed	360° continuous / 180° per second (excluding ramping)	
Tilt rotation limit / speed	+90° to -30° upright (-68° inclined) +30° to -90° inverted 180° per second (excluding ramping)	
Weight (with adaptor)	7Kg (8Kg) 15.43lb (17.63lb)	
Mounting profile	Upright / Inverted / Offset	
Pan/tilt bearings	Sealed for life - no maintenance required	
Motor drive	Long life toothed polypropylene belt drive Pulleys bonded to keypad shafts for minimum backlash	
Environmental rating	IP67	
Operating temperature range (ambient, dry)	-20°C to +60°C (-40°F to +140°F with optional heater) -4°F to +150°F (-40°F to +150°F with optional heater)	
Mounting	4" PCD mount	
Connection socket	IP67 Neptune multi-way SD, IP67 Marine HD-SDI option and IP67 IP option	

Electrical, electronic and software specifications

Optical encoder preset accuracy	0.01°
Rotational contacts	Heavy duty slip rings for power, data, video, switching for washer
Position control	"Capable of retaining position without drift Automatic position recovery if forced away by a "non-control" intervention"
Roll around mode	Auto 180° pan spin when tilt reaches end of travel while following subjects
Configuration	Via on screen menus
Presets	127 + wash preset (repeatability 0.05°)
Tours	16 preset tours (maximum of 60 positions each), four 8 minute mimic tours
Privacy zones	Maximum of eight on-screen simultaneously
Communications	Coaxial or RS485 half duplex data comms with absolute positioning output
Supported protocols	Pelco-D, Pelco-P, CBC OCP485, Forward Vision Mic1 FV300, Philips, Vicon.
Power requirements	"At Oculus unit: 14 to 36VDC or 14 to 26VAC, 45W peak (100W with optional heater) Supplied PSU requires 230VAC. 12VDC support on some models"
Additional details	In-built real-time clock

Detection, Recognition, Identification range charts

DB Type Thermal

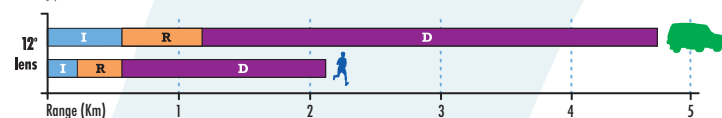

Key to Johnson's Criteria charts

- D** Detection - an object is present (-2 pixels)
- R** Recognition - the object can be discerned (- 8 pixels)
- I** Identification - the object can be identified e.g. male versus female, a specific car (- 12.8 pixels)

Note: Ranges may vary depending on atmospheric conditions

Dimensions (in millimeters)

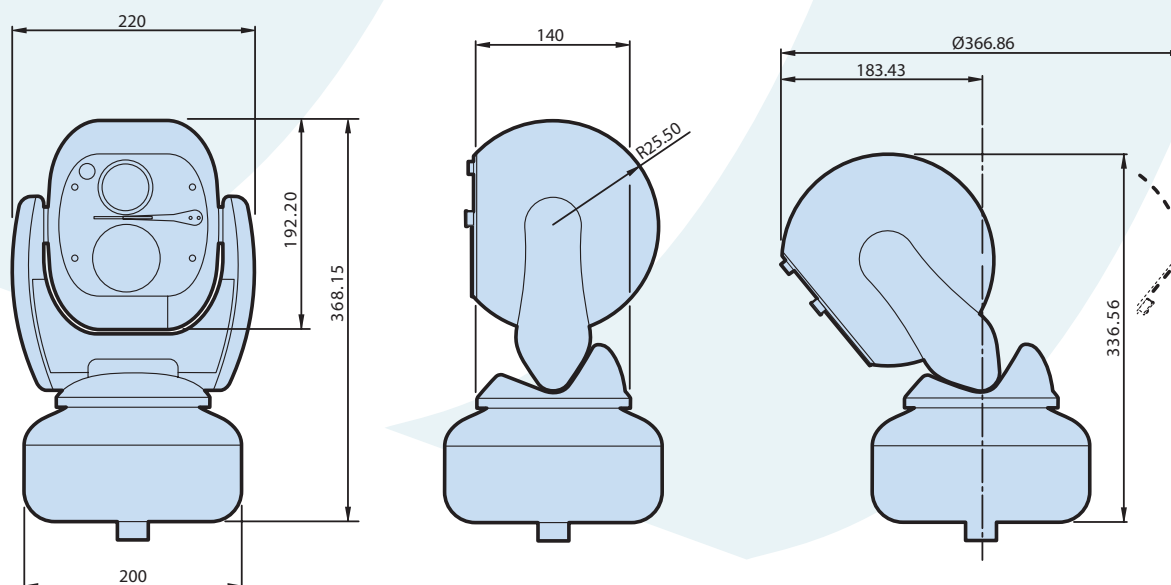

Designed and manufactured in the UK.

Specifications may be subject to change without notice • DN010914 - 1.1c • © 2014