



POWER & ENERGY METERS



BEAM PROFILING



THZ MEASUREMENT

# LASER BEAM MEASUREMENT & BEAM PROFILING

PRODUCT GUIDE **2015**

MID-YEAR EDITION

# NEW FOR SUMMER 2015

**NEW**

## COMPACT LASER POWER METER

FOR QUICK MEASUREMENTS UP TO 250 W

Gentec-EO is pleased to announce the launch of its brand new Pronto Laser Power Meter. This new meter is small but strong, with 250 W of **instantaneous laser power measurements**, thanks to an all-metal casing and the **strongest absorber** on the market. With its **intuitive touch screen display and unbeatable price**, the Pronto power meter is simply **perfect for laser marking applications**.

small  
but

**STRONG**

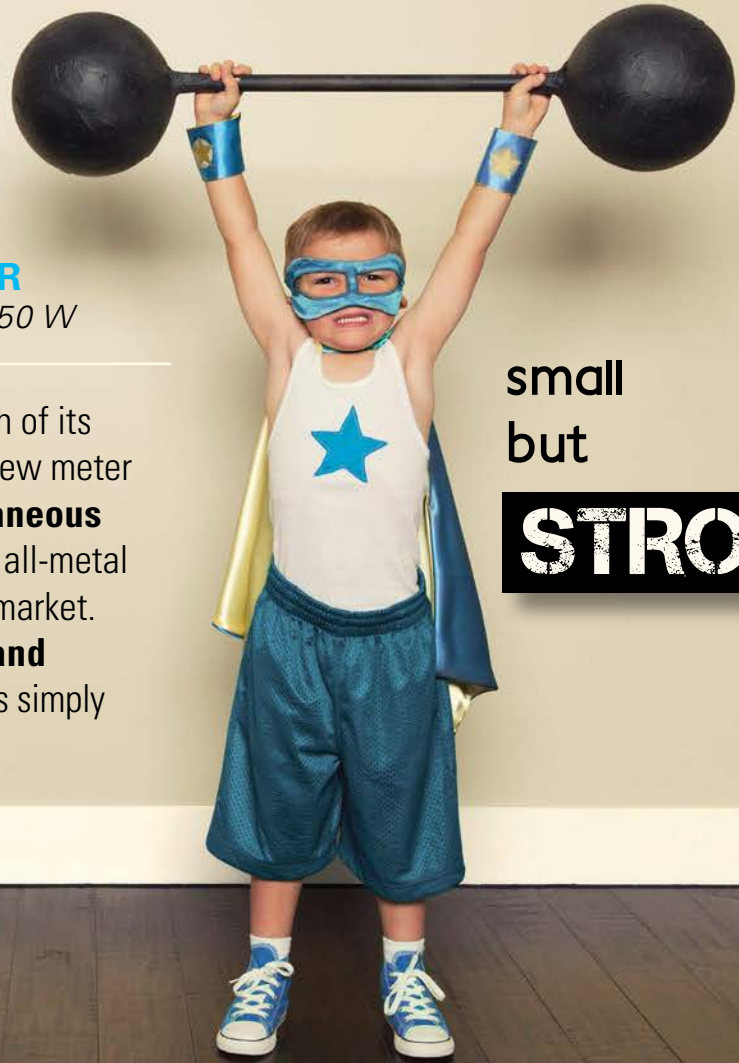

## PRONTO-250

- ★ Pocket-Sized
- ★ Easy-to-Use
- ★ Color Touch Screen Display
- ★ From Low to High Powers (1 to 250 W)
- ★ Advanced Features like Data Logging and Data Transfer to PC
- ★ Available in **2 Models**:
  - **Pronto-250**: Broadband YAG Calibration (0.248 – 2.5  $\mu\text{m}$ )
  - **Pronto-250-CO<sub>2</sub>**: CO<sub>2</sub> Calibration



See page 82

# PRODUCT GUIDE

**2015**

<b>COMPANY</b>	<b>4</b>	<b>PHOTO DETECTORS</b>	<b>108</b>
About Gentec-EO	4	Presentation	108
<b>HOW IT WORKS</b>	<b>6</b>	Comparison Table	109
Calibration	6	PH-B	110
Energy Detectors	12	PH	112
Power Detectors	14	PE-B	114
<b>MONITORS</b>	<b>18</b>	Technical Drawings	116
Presentation	18	Absorption Curves	117
Comparison Table	19	<b>THZ DETECTORS</b>	<b>118</b>
MAESTRO	20	Presentation	118
TUNER	24	THZ-D	120
UNO	26	THZ-I-BNC	122
S-LINK	28	THZ-B	124
P-LINK	30	QS-THZ	128
M-LINK	32	Technical Drawings	130
INTEGRA	36	Absorption Curves	132
<b>ENERGY DETECTORS</b>	<b>38</b>	<b>OEM DETECTORS</b>	<b>134</b>
Presentation	38	Presentation	134
QED Attenuator	39	UD Series	136
Comparison Table	40	UP series	138
QE-B	42	UP Series + PCB	140
QE12	44	<b>SPECIAL PRODUCTS</b>	<b>142</b>
QE25	46	Presentation	142
QE50	48	Ultrafast Joulemeter	144
QE65	50	MACH 6	144
QE95	52	Discrete Pyros	148
Technical Drawings	54	QS-L	149
Absorption Curves	56	QS-H	150
<b>POWER DETECTORS</b>	<b>58</b>	QS-VL	151
Presentation	58	QS-IF	152
Comparison Table	60	QS-IL	153
XLP12	62	Position Sensing Detectors	156
UP12-H	64	QUAD	156
UP19-H	66	Custom Products	160
UP25-H	68	Calorimeters	164
UP55-H	70	Presentation	165
UP17-H/W	72	Applications	166
UP19-W	74	Technical Aspects	167
UP50-W	76	Technical Drawings	168
UP19-VR	78	Absorption Curves	169
UP55-VR	80	<b>BEAM DIAGNOSTICS</b>	<b>170</b>
PRONTO-250	82	Presentation	170
UM-B	84	Beamage	172
FLASH-IPL	86	Camera Accessories	178
Technical Drawings	88	Wavelength Management	178
Absorption Curves	92	Beam Size Management	181
<b>HIGH POWER SOLUTIONS</b>	<b>94</b>	Power Management	182
Presentation	94	<b>ACCESSORIES LIST</b>	<b>184</b>
UP55-HD	96	<b>DISTRIBUTORS WORLDWIDE</b>	<b>186</b>
HP	98	<b>RETURNS &amp; WARRANTY</b>	<b>189</b>
SUPER HP	100		
FLASH	102		
Beam Dumps	104		
Technical Drawings	106		

# ABOUT GENTEC-EO



Photo courtesy of Lawrence Livermore National Laboratory

Located in the heart of the Quebec Optical Hub, in beautiful Quebec City, Canada, Gentec Electro-Optics (Gentec-EO) has a long history in the laser measurement field. With a 40 year track record of innovation and providing quality solutions for laser power and energy measurement applications from the factory to the hospital and laboratory, Gentec-EO stands ready to serve you now and in the future.

# PRESENTATION



## MILESTONES

The first laser energy meter in the world has been initially developed for internal use as Gentec Inc. were putting the first high repetition rate TEA CO<sub>2</sub> lasers on the market in 1970. Gentec, Inc. introduced the first pyroelectric joulemeters shortly after that. They were also the first to manufacture both thermopile wattmeters and pyroelectric joulemeters. In the mid 1990's, Gentec introduced the WB series with an average power density damage threshold of 100 kW/cm<sup>2</sup> that is still unrivalled today. In 2000, Gentec Electro-Optics, Inc. was formed from Gentec, Inc. so that the focus was entirely on laser measurement. And in 2010, the acquisition of Spectrum Detector Inc. allowed Gentec-EO to cover new markets, like THz Detectors, Ultra-Fast Pyroelectric Detectors and Highly Sensitive Photo Detectors, to name a few.

## OUR ESSENCE

The decision of adopting "Partners for Accuracy" as our branding slogan is the result of a long evolution that spanned over more than 40 years. It came to us naturally since it represents our very essence. We have always aspired to be more than a simple supplier of state-of-the-art laser measurement technologies. We truly believe that developing a very close partnership with our customers is essential and beneficial for every party. By definition, "partnership" means "aiming at the same goal" and "working together". This is what is driving us. As for "Accuracy", it does not solely refer to the precise measurements we are able to provide, but also to the complete understanding of our customers' needs and expectations. Finally, the key to our success is to focus all our energy into "rigorousness". No matter what the situation, Gentec-EO is always proud to offer its customers the most accurate laser measurements as well as the most personalized help for the development of custom products and solutions.

Let us be, your *Partners for Accuracy*.

## WORLDWIDE PRESENCE

Gentec-EO has an evergrowing presence everywhere around the world. Each year, we keep adding new partners in various countries. Our latest additions are South America, Mexico and Greece. We also have a strong presence in most of the European and Asian countries and, following the acquisition of Spectrum Detector, we now have an office in the US. When you send a unit to us for repair or recalibration, you are entitled to expect your unit back in as short a time as possible.

With calibration centers on 3 continents, and offices both in Canada and the US, Gentec-EO has a solid presence and fast turnaround times, just what you need to keep pace with today's rapid market.

**gentec-EO**  
PARTNERS for ACCURACY



# CALIBRATION



At Gentec-EO, we understand that the essence of our business since 40 years has been delivering accuracy. There are no half measures: it either measures accurately or it doesn't. This is why one of our company's values is "rigourousness", because our customers expect nothing less.

# CALIBRATION

## THE GENTEC-EO ADVANTAGE



We use only **GOLD Calibration Standards**, guaranteeing our customers the lowest calibration uncertainty possible



For each detector that we calibrate, **50 Parameters are collected and logged** in our quality system



**The calibration reference is checked 2 to 3 Times** during EACH calibration process

Our uncertainty values are based on **Proven Statistical Calculation Processes**



Our Personal Wavelength Correction™ (PWC) data offers you **NIST and/or NRC Traceability over the entire range of the detector**



Each of these steps contributes to the **TOTAL ACCURACY** of your detector



## THE TERMS

### ACCURACY

The accuracy of a measurement is defined as the closeness of the agreement between the result of a measurement and the true value.

### UNCERTAINTY

Uncertainty is a measure of the “goodness” of a result. The definition and concept of uncertainty is a quantitative attribute to the final result of measurement, considering all systematic and random components of all known input quantities.

### ERROR

The error on a measurement is the difference between the measurement result and the true value.

### REPEATABILITY

The repeatability is the closeness of the agreement between the results of successive measurements under the same conditions of measurements.

### REPRODUCIBILITY

The reproducibility is the closeness of the agreement between the results of successive measurements under changed conditions of measurements. This is also defined as “precision under reproducibility conditions”.

### PRECISION

The precision of a measurement is defined as the closeness of agreement between independent test results obtained under stipulated conditions.

MONITORS

ENERGY DETECTORS

POWER DETECTORS

HIGH POWER SOLUTIONS

PHOTO DETECTORS

THz DETECTORS

OEM DETECTORS

SPECIAL PRODUCTS

BEAM DIAGNOSTICS

# CALIBRATION

## THE CALIBRATION PROCESS

MONITORS

ENERGY DETECTORS

POWER DETECTORS

HIGH-POWER SOLUTIONS

PHOTO DETECTORS

THZ DETECTORS

OEM DETECTORS

SPECIAL PRODUCTS

BEAM DIAGNOSTICS



**1** Comparison Process



**4** Certification



ACCURACY

**2** Gold Standard

**3** Uncertainty Calculation



# CALIBRATION

## THE TECHNIQUE

By definition, calibration is a comparison between measurements, one of a known magnitude or correctness, which is typically called a “gold standard”, and another measurement comparable to the first one. In the calibration process, there are four critical aspects that need to be controlled precisely:

1. Comparison Process
2. Gold Standard (Traceability)
3. Uncertainty Calculation
4. Certification

### 1 COMPARISON PROCESS

The first step in the calibration process is the comparison to a known and traceable standard. At Gentec-EO, we always do this using Gold and not a Silver calibration standards, unlike some of our competitors. This extra carefulness in the comparison process comes from decades of experience in the laser measurement business.

### 2 GOLD STANDARD

Gentec-EO's gold laser power detector heads are compared to NIST standard calorimeters at different wavelengths, in accordance to the different lasers used to calibrate your own detector heads. The laser beam has a nominal diameter appropriate for the detector, and is centered on the detector's absorbing surface. The laser energy impinging upon the test instrument is measured concurrently using a NIST standard calorimeter and a calibrated beam splitter. The beam splitter ratio is measured using NIST standard calorimeters. Before the measurements are performed, the test instrument is allowed to reach equilibrium with the laboratory environment. The calibration factor is found by dividing the instrument output reading by the calculated average incident laser power. The calculation is based on the output reading of the NIST standard calorimeters.

### 3 UNCERTAINTY CALCULATION

At Gentec-EO we offer the best uncertainty on the market, which means more than just giving the customer the lowest uncertainty value. These calculations also need to follow recognized statistical calculation standards, including those given in NIST's Technical Note 1927. Another important parameter to verify, and one that is less known, is the confidence level. At Gentec-EO, we use a very high confidence level of 95%. Like every other step in the calibration process, our uncertainty calculations are done rigorously. We don't aim to give you just the lowest number, whatever its meaning, we rather aim to give you the true value, with the highest confidence possible.

### 4 CERTIFICATION

Gentec-EO has been using its own control quality system for many years and is now accredited ISO 9001:2008. Over and above the quality system certification process, the most important aspect is how rigorously the different steps and parameters are controlled in order to deliver an accurate calibration day after day.

# CALIBRATION

## ELECTRICAL INSTRUMENTS

All of our electrical instruments are calibrated by certified calibration suppliers. They certify that, at the time of calibration, the instruments used for calibration meet or exceed all published specifications and have been calibrated using standards whose calibrations are traceable to the NIST and/or other recognized international standards. The electrical and physical properties of their laboratories meet the highest requirements for ambient temperature, relative humidity and cleanliness. Their equipment is maintained by procedures that meet the requirements of ISO 9001:2000 and ISO 10012:2003.

## THE FACTS

### HOW GENTEC-EO CALIBRATES YOUR DETECTOR

Every detector is individually calibrated to the best possible accuracy traceable to NIST standards. Stable laser sources at various wavelengths are used in our calibration process.

### UNCERTAINTY

One very common misconception is the absolute value of calibration uncertainty. Be aware that this value is made using a complex statistical method that takes in account ALL the sources of uncertainty that are present in the process. Figure 1 below shows these steps and their respective contribution to the value of uncertainty. As you can see, the manufacturer itself is only one of these sources.

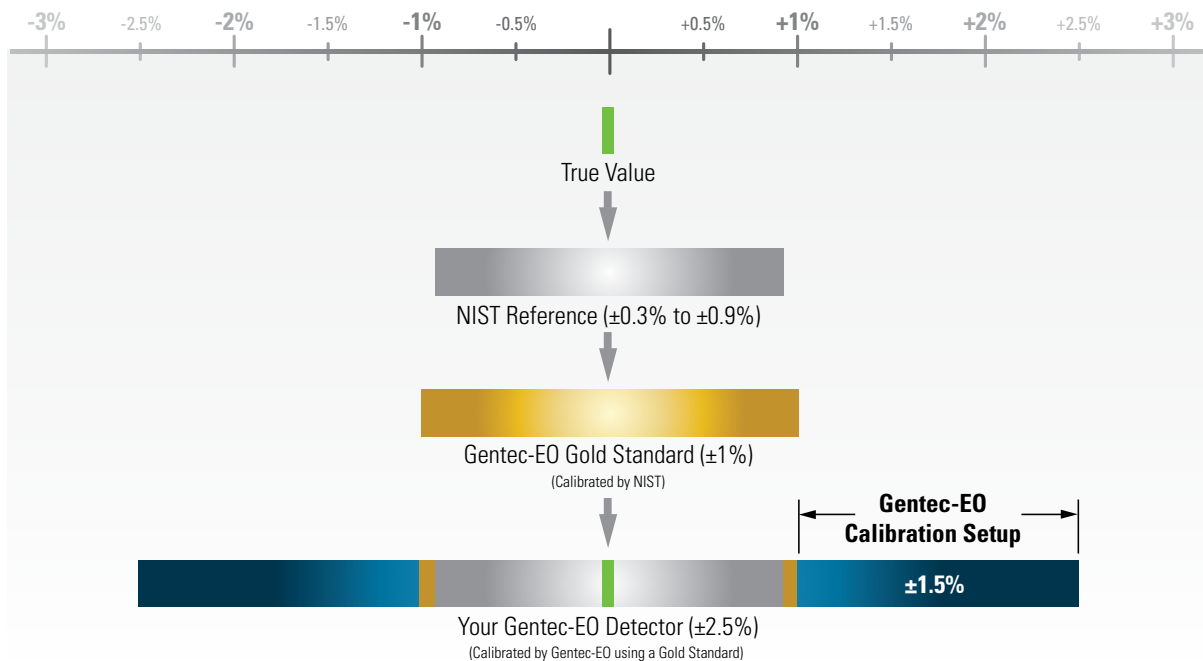

Figure 1. Sources of uncertainty in the calibration of a detector

MONITORS

ENERGY DETECTORS

POWER DETECTORS

HIGH POWER SOLUTIONS

PHOTO DETECTORS

THZ DETECTORS

OEM DETECTORS

SPECIAL PRODUCTS

BEAM DIAGNOSTICS

# CALIBRATION

## CALIBRATION WAVELENGTHS

Another misconception is that any wavelength can be NIST calibrated. The NIST only supplies references for distinct wavelengths contained between 157 nm (F<sub>2</sub> excimer lasers) and 10.6 μm (CO<sub>2</sub> lasers). Every other wavelength within this range or out of this range is subject to an additional error.

For more information about NIST's calibration wavelengths, please visit their website at: <http://www.nist.gov/calibrations/cal-op.cfm>

## PERSONAL WAVELENGTH CORRECTION™ CERTIFICATE

To fill the gaps between the NIST references, Gentec-EO offers you the only NIST traceable calibration in nm steps, from 250 nm to 2.5 μm. We achieve this using our proprietary setup that is based on a NIST traceable spectrophotometer. This way, instead of supplying you with typical values, we offer you a NIST traceable calibration. What you get is an overall accuracy that is not more than ±1% away from the original calibration accuracy, in the spectrum of 300 to 2200 nm.

Each Gentec-EO detector comes with a Personal Wavelength Correction Certificate. The correction factors are based on measurements that were made with YOUR detector. They are not based on the general curve of the absorbing material or the general response of equivalent products. This means you get the best wavelength correction tool available on the market. This data is stored in the Smart Interface of your Gentec-EO detector, you just have to select the wavelength in your monitor to get the most precise laser measurements on the market.



Your Detector Model

**Personal wavelength correction™ Certificate**

Spectral Absorption Plot measured for: UP19K-50L-H5-INT-D0 Power Detector Serial #220022

Absorption Curve of your Detector

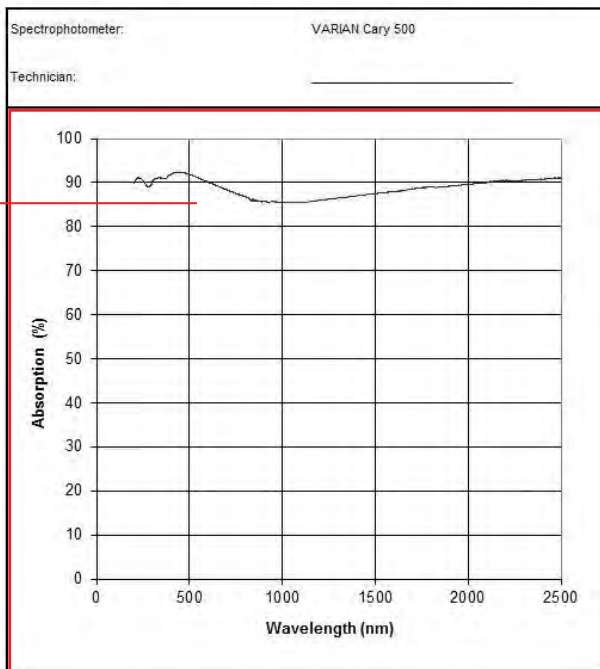

Personal Wavelength Correction™	
Wavelength (nm)	Correction multiplier
193	0,948
213	0,942
248	0,943
266	0,955
308	0,943
337	0,938
355	0,939
488	0,929
514	0,932
532	0,935
578	0,944
632	0,954
694	0,966
720	0,971
810	0,986
980	0,999
1064*	1,000
1550	0,974
2100	0,949
10600**	0,930

\* Calibration wavelength  
 \*\* Typical value  
 traceable.  
 For Gentec-EO monitors, select the proper wavelength in menu  
 For other monitors, multiply by the correction multiplier  
 Energy corrected = Energy read x correction multiplier  
 Example: Energiv (488 nm) = -10mJ x 0,929 = 9,29 mJ

Wavelength Correction

- 1 Wavelengths programmed in the EEPROM (nm) (Based on the Absorption Curve of your Detector)
- 2 Calibrated Wavelength (nm) (Using a Gold Standard)
- 3 Correction Factors (Multipliers)

For more info, see Application Note [202184](#) - Understanding your Calibration Certificate.

# ENERGY DETECTORS

## ENERGY DETECTORS AT GENTEC-EO

Gentec Electro Optics provides a full range of products to meet your pulse energy measurement needs. They range from the lean and portable QE12 and QE25 series, the large aperture QE50, QE65 and QE95 series to our large world class custom calorimeters. Having introduced the first pyroelectric joulemeter over 40 years ago, Gentec-EO is well established as an experienced source of energy measurement expertise. Be it in the laboratory or an OEM application Gentec-EO will have a solution.



## HOW THEY WORK

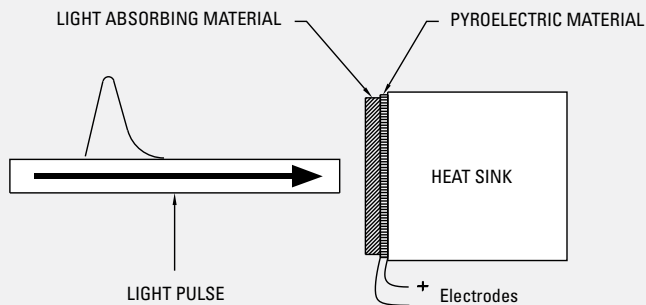

Figure 1. Joulemeter Construction

In the simplest terms, a pulse of light is absorbed by the surface of the detector and heats it up. That in turn, changes the temperature in a pyroelectric material underneath. This separates electrical charges in the pyroelectric which creates a voltage as the pulse of heat energy passes through it to a heat sink. The heat sink removes the heat energy to allow the pyroelectric to be ready for another pulse and to prevent it from over heating. The electrical voltage read by the measuring instrument is proportional to the energy. Figure 1 sketches out the basic structure of a pyroelectric joulemeter.

## THE ABSORBER

The business end of the detector is the absorber that coats the side of the pyroelectric that is exposed to the laser. That material absorbs most of the light energy from the laser and converts it to heat. A small fraction is reflected. How much is shown by the spectral response curve for the material. The thermal mass of the absorber and its thickness determine how quickly the heat can flow to the pyroelectric detector and hence its response time. Lowering the thermal impedance by using an absorber with a lower thermal mass or reducing the thickness of the absorber will increase its speed. The metallic MT coating is a good example. It allows for a measurement of each pulse up to 4000-6000 Hz.

## THE PYROELECTRIC

The heart of every Gentec-EO energy detector is a fast response pyroelectric material. It acts as a source of electrical current when subjected to changes in temperature provided by the absorber. Essentially it contains permanent electrical dipoles that are oriented in a specific direction. A rapid temperature change in the material will alter the orientation of these dipoles. That changes the internal electric field and causes an imbalance in electrical charge between the 2 large sides of the device. There are thin metal electrodes on these surfaces. They allow the charge to flow from one electrode into a circuit with a load resistor and then back to the crystal via the other electrode to eliminate the imbalance. The electrical current is converted into a voltage signal by the load resistor.

# ENERGY DETECTORS

## THE VOLTAGE RESPONSE

The result is a voltage pulse that rises quickly with the response time of the device to a level proportional to the laser energy (Figure 2). It then decays exponentially over a longer period of time that is a function of the pyroelectric device and load impedance. Figure 2 also shows that there is a longer recovery time to return to the initial state of the detector. This is a function of thermal phenomena and is not affected by the load impedance as are the rise and decay times. The integrated pulse energy over this period is proportional to the peak voltage.

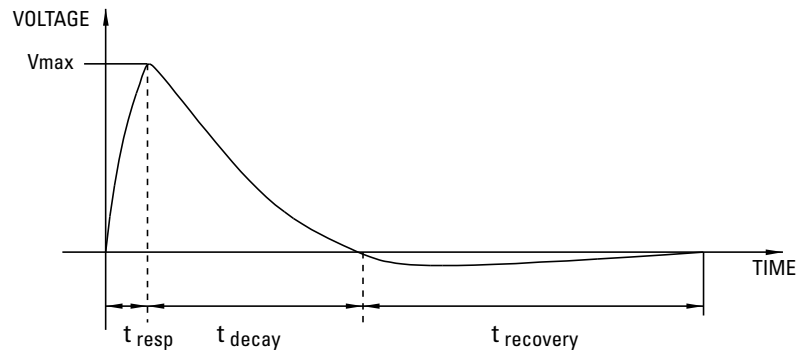

Figure 2.  
Typical voltage response  
of a Gentec-EO energy detector

## THE MEASUREMENT

The laser energy is given by the change in voltage divided by the sensitivity (in Volts/Joule) of the detector. The measured voltage is the change from the initial reference voltage to the maximum voltage of the pulse. The sensitivity is provided by Gentec-EO on our NIST-traceable calibration certificate. We measure this with extreme care with a well known laser energy provided by an NIST standard. This sensitivity is for the specific load impedance that is requested. The user can measure the voltage on an oscilloscope or computer data acquisition system and use the sensitivity value to make the energy measurement. An easier option is to read it directly in Joules from a Gentec-EO MAESTRO or S-LINK monitor, or when using our new integra series.

## THERMALLY ROBUST

The energy detector will make accurate measurements in spite of changing temperature in the environment or heating of the detector as long as the maximum voltage does not saturate. This is because it is the difference between the initial and peak voltages that measures the pulse energy. This relative measurement is good until the peak voltage is prevented from reaching its natural value by the maximum voltage available in the electronics.

## DAMAGE THRESHOLDS

Excessive pulse energy that is concentrated into to a small area can damage energy detectors. For the most demanding laser beams we offer the broadband MB coating which has pulse energy density thresholds that are among the best in the world. Slight discoloration from short pulses is due to a modification of the organic material in the absorber that does not affect the detector calibration. If enough of the coating is removed by ablation to expose the metal electrode underneath, then the output voltage may be affected too much for the application. Too much average power, (that is above the manufacturer's specification) can cause the detector to overheat. Contamination on the absorber surface can also interfere with the measurement or damage the detector by concentrating too much energy in one spot. Grease, dust, and fingerprints are some of the common contaminants to avoid.

View our complete line of pyroelectric Energy Detectors on page **38**

# POWER DETECTORS

## POWER DETECTORS AT GENTEC-EO

Well established in this field for over 40 years Gentec Electro Optics has been a leader in the field of laser power and energy measurement. The average power density damage threshold of  $100 \text{ kW/cm}^2$  that we introduced with the WB series in the mid 1990's is still unsurpassed. Gentec-EO also offers you broadband spectrally flat power detectors for general use in the UP12-H & UP19-H series, high peak power pulse damage resistance for specific UV and IR bands with the UP19-VR series, and high average power detectors in the air and water cooled High Power UP25-H, UP55-H & UP55-HD for the big jobs. All our detectors are available in OEM version and different size disks as well. Whatever your need Gentec Electro Optics has a solution.



## HOW THEY WORK

### HEAT SINK

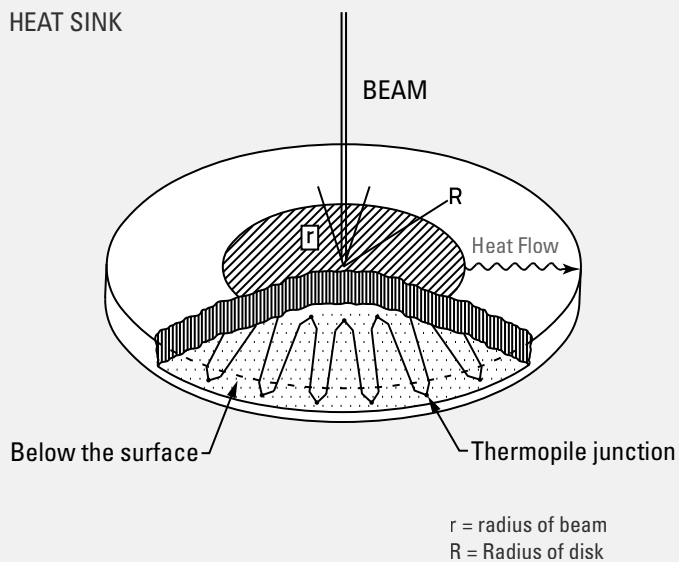

Figure 1. Disk type thermopile

The basic laser power detector is essentially a thermopile. The more familiar application for thermopiles, in fact where the common name “thermo electric cooler” comes from, is when a voltage is applied to cool one side of the thermopile and whatever it is bonded to. Thermopiles for laser power measurement however are used in the opposite fashion. That is, a temperature difference is used to create a voltage. On one side is material heated by the laser and on the other is a heat sink. The laser energy absorbed by that material is converted to heat. With the hot absorber on one surface and the cold heat sink on the other, there is a temperature difference across the thermo electric device as the heat flows through it. This temperature difference causes the thermopile to generate a voltage. That voltage is proportional to the temperature difference which in turn is proportional to the laser power. The monitor measures this voltage to provide the laser power reading in watts. Figure 1 shows the fundamentals of the thermopile-based power detectors.

## THE ABSORBER

The optically absorbing material is one of the most important parts of the detector. That is because its properties define much of the performance of the detector, especially its resistance to pulse damage. This material absorbs most of the light energy from the laser and converts it to heat. A fraction is reflected that can vary from a few percent to 50% of the total optical power, depending on the material and intended application. How much is shown by the spectral absorptivity response curve for the material. With an absorber like our broadband H coating, around 90% of the power may be absorbed across a very wide range of wavelengths (190 nm to  $20 \mu\text{m}$ ) with small variations. This is called a spectrally flat absorber. It is efficient and because of its low thermal mass it transfers the heat quickly.

# POWER DETECTORS

## THE HUMBLE BEGINNING

A thermopile is simply an array of thermocouples connected in series and close together. The fundamental technology of all state-of-the-art thermal laser power detectors actually goes back to 1821! That is when Thomas Seebeck joined two wires of dissimilar materials together at both ends and discovered electrical current flowing when he heated one end. Moreover, he found that the voltage between junctions was proportional to the temperature difference between them. That is called the Seebeck voltage and became the basis for the thermocouple. Years later Lord Kelvin (William Thomson) explained it. Essentially, the heat causes electrons to diffuse away from one end of a wire to the other. Since the effect is different for different metals, there is a net difference in voltage where the metals join, hence Seebeck's voltage. Peltier made his contribution in 1834 by observing that heat could be made to flow into, or out of, the junction depending on which way you make the current flow. Modern thermocouples are made by the joining of specially formulated metal alloys and even specially doped semiconductor materials.

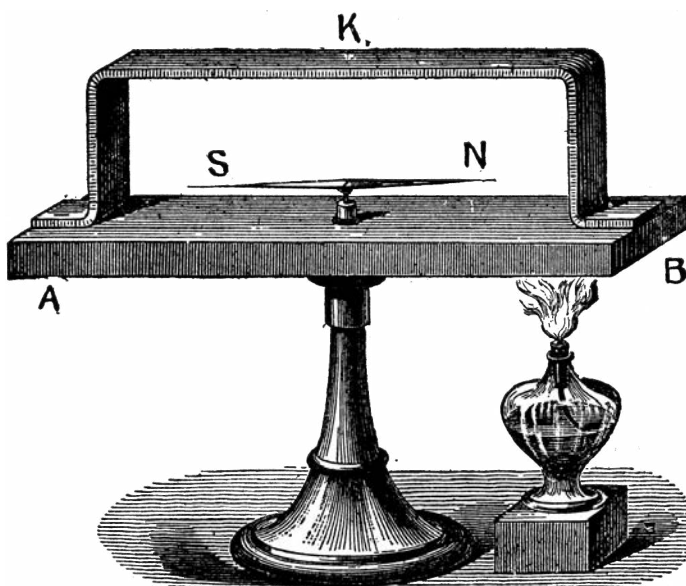

Figure 2.  
Seebeck's thermopile

## THE THERMOCOUPLE

A practical view of a thermocouple is essentially 2 wires of different metals attached at both ends like in Figure 3. One junction goes to the “hot” side of the device and the other goes to the “reference” or cold side of the device. In laser power measurement, the hot junction is placed next to the absorber and the other next to the heat sink. Any temperature difference between the two junctions causes a voltage difference between them. That electrical voltage is proportional to the temperature difference, therefore to laser power. This is the voltage that is measured by the power monitor to provide the power reading.

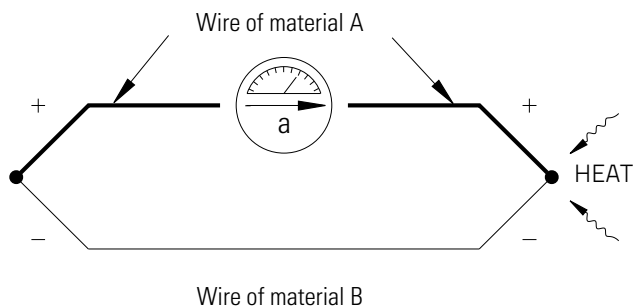

Figure 3.  
The thermocouple

# POWER DETECTORS

## THE THERMOPILE

The amount of voltage that can be produced by one thermocouple is small, so an array of thermocouples is connected in series to increase sensitivity and multiply the output. In the array, instead of the two wires being joined twice to each other, each wire is joined to two wires of the other type, but a different one at each end. The junctions alternate back and forth so that each wire has a junction on the hot side, and another on the cold side. This is easier to visualize in Figure 1. The more numerous and closer together the junctions are, the more sensitive the thermopile will be. So it gives more voltage for the same laser power.

## HOW THEY WORK

### DISK THERMOPILE

Two kinds of thermopiles are used in laser power measurement. One is the disk thermopile shown in Figure 1 and the other is the wafer-type thermopile. The disk is made of one set of junctions laid out radially. One set of junctions is arranged under the aperture while the alternate set is near the edge of the disk which is attached to a massive heat sink. The laser power heats the absorber in the center and creates a temperature difference between the center and the edge. The thermocouples generate a voltage corresponding to this difference.

The primary difference with the second type is that the heat flows radially through the disk which can handle more average power, especially with blown air or water cooling. The disk thermopile also has a much faster natural response time. Gentec-EO offers a complete line that combines a new technology disk with different cooling ways like heat-sink, fan or water cooling module.

### WAFER-TYPE THERMOPILE

The second one resembles a wafer, or sandwich, with thermocouples running between the two sides. One rectangular face of the wafer thermopile receives the heat. That creates a large temperature gradient across the small distance to the other face that is in contact with the massive heat sink. The array of solid state thermocouples in the thermopile generates a voltage proportional to this gradient just like in the disk thermopile. Because of the close spacing of the thermocouples to each other, the resulting large number of thermocouples in the wafer, and the large temperature gradient across the two surfaces, the output voltage of this thermopile is the most sensitive to laser power and the least sensitive to beam position and size.

## ANTICIPATION

The voltage response of a thermopile to the incoming power is predictable. It can be modeled. All Gentec-EO monitors have circuitry and software that model the incoming pulse and accurately predict its peak value before it actually occurs. This "anticipation" circuitry allows the wafer type thermopiles to have a much faster accelerated response time when used with a Gentec-EO monitor than the natural response time of the device.

View our complete line of thermopile Power Detectors on page **58**

# POWER DETECTORS

## DAMAGE THRESHOLDS

### THE THERMOCOUPLE

An average power that is too high simply overheats the detector until it damages the thermocouple junctions. As a consequence, the thermopile itself and the cooling system determine the average power capacity of the detector. This is also what you risk if you exceed the manufacturer's specification for too long. To avoid overheating, we offer the UP series which can, with its newest design, take a lot more heat than the usual thermopile.

### AVERAGE POWER DENSITY

Concentrating too much energy into too small an area can damage the absorber. Hence, the absorber determines how much energy and power density the detector can take. There are two fundamental types of damage. The first is from slow thermal effects and the second from short pulse impacts. The slow thermal damage is due to local heating when the average power density is too high. The result is melting, vaporizing and/or cracking of the absorber. CW, QUASI-CW and lasers with high repetition rates, such as used in micromachining can create high average power density, especially with small beam diameters. For these demanding laser beams, we offer the W5 and W9 Series which have, at 100 kW/cm<sup>2</sup>, the highest average power density threshold available today. For the most challenging cases, expanding the beam is often the easiest way to reduce the power density to something manageable.

### PEAK POWER DENSITY (PULSED)

When the pulse energy is concentrated into too short a time, as well as space, it explosively vaporizes some of the absorber material at the surface. That ablates or knocks away some of the absorber. When the thermopile underneath is eventually exposed, the sensitivity may be affected too much for the application. The VR series (volume absorbers) are designed to take the concentrated pulse energy by distributing it through a volume instead of just on the absorber surface. Unlike the broader band materials which absorb the energy right on the surface, the energy is absorbed throughout the thickness of the material. That spreads the energy throughout a cylindrical volume rather than just over an area of the beam diameter. Energy densities greater than 30 J/cm<sup>2</sup> and peak power densities above 100 GW/cm<sup>2</sup> can be handled this way depending on the wavelength. If damaged by excessive pulse energy density or peak pulse power density our absorbers can be easily replaced in the field.

### WAVELENGTH

The other important consideration is wavelength. Energy from the longer wavelengths, like Mid and Far IR tends to penetrate deeper into the absorber. Damage from exceeding the specification may occur first at the absorber-thermopile interface and work its way up to the surface. In the shorter wavelengths the energy is concentrated closer to the absorber surface. In the case of UV the photons are so energetic and concentrated on the surface that they cause electronic as well as optical-thermal damage. Essentially, they knock electrons out of atoms in the absorber material. Gentec-EO offers broadband absorbers for all kind of wavelength as well as absorber for specific wavelength. In practice, a combination of the two mechanisms is often at play and both may be visible. If your application is pushing the limits pay attention to the damage thresholds provided by the manufacturer and the spectral absorptivity curve for the material to adjust for wavelength where necessary.

### THE BOTTOM LINE

Damage to the absorber surface, whatever the mechanism (even if you scratch it), is only an issue when it changes the ratio of power reflected versus absorbed at your laser wavelength. Visible discolorations may not mean much at the wavelength of your laser if it is outside of the visible light spectrum. Then again they might. If more power is reflected, less will be absorbed so the detector will be less sensitive than when it was calibrated. When this damage is severe enough, and covers enough of the area under the beam to affect the accuracy required by the application, you should send the detector for recalibration, and possibly service. For many applications an annual recalibration is good policy.

# PRESENTATION

## OVERVIEW OF THE DIFFERENT MODELS

The Gentec-EO monitors come in various sizes and types to cover all applications. We have monitors with or without display (PC-based) and for power or energy readings, or both. We also offer the fastest digital needle display on the market.



### MAESTRO

The MAESTRO Power & Energy Meter is our top of the line display monitor with an extra-large 5.6in color LCD display and fully touch screen controls. With its unique user interface and faster electronics, it will do more, in less time, and with less effort than any other meter on the market!



COLOR LCD

MULTIPLE LANGUAGES\*



See page **20**

\* Every language may not be available yet



### TUNER

This Power Meter presents both a large LCD display and an ultrafast needle, up to 10X faster than anything else on the market. It comes with more features than the competition, like min and max holds for both displays, comet tail needle and bar graph function. The TUNER comes in Gentec-EO's ergonomic design, with a large LCD display and easy to use direct access keys.

■ ULTRA-FAST TUNING NEEDLE

See page **24**



### UNO

The UNO is a simple Power Meter, with large contrast fields and direct access buttons. Its extremely low power consumption allows it to work on standard alkaline batteries, making it the monitor of choice for service technicians working in the field. With the lowest price for a display meter, the UNO is the perfect choice when looking for a reliable, entry-level power meter.

■ ECONOMICAL POWER METER

See page **26**



### S-LINK, P-LINK & M-LINK

The S-LINK, P-LINK and M-LINK are PC-Based Power or Energy monitors that come with unique software applications. The S-LINK comes with 1 or 2 channels and measures energy detectors at a very fast rate. It comes with a USB interface, Ethernet being available in option. The P-LINK is a small power meter, available with either a USB or RS-232 interface. A 4-Channel version is also available. As for the M-LINK, it is a Universal Power & Energy Meter that measures ALL the detectors in our product range and features a unique noise suppression method.

■ PC-BASED POWER OR ENERGY METERS

See page **28, 30 and 32**

# COMPARISON TABLE

## integra ALL-IN-ONE DETECTOR + METER



The INTEGRA is a meterless line of All-in-One detectors that combine a detector and a meter in one convenient product. The small but powerful meter of the INTEGRA Series presents a direct USB connection so you can plug it into your PC. Simply use the PC-Gentec-EO software supplied with your product and be ready to make power or energy measurements within seconds! Each detector of the INTEGRA Series offers the same incredible performance as the usual detector and meter combination, from pW to kW and from fJ to J. And the good news is that all our most popular products are available with the Integra option.

Watch out for the INTEGRA logo on the product pages to identify the products available with INTEGRA.

See page 36

## COMPARISON TABLE



	MAESTRO	TUNER	UNO	S-LINK	P-LINK	M-LINK	INTEGRA
<b>DETECTOR COMPATIBILITY</b>							
Power (Thermopiles)	●	●	●	●	●	●	●
Power (Pyroelectrics -B)	●					●	
Power (Photo Detector)	●	●	●		●	●	●
Power (Photo Detector -B)	●			●		●	
Power (THZ-D Detector)	●					●	
Energy (Pyroelectrics)	●			●		●	●
Energy (Pyroelectrics -B)	●			●		●	●
Energy (Thermopiles in Single Shot)	●			●	●		●
Energy (Photo Detector -B)	●			●		●	●
<b>DISPLAY</b>	5.6in LCD Touch Screen 18bit Color	3.8in LCD With Tuning Needle	3.8in 32 mm Digits High Contrast	None	None	None	None
<b>PC INTERFACE</b>	●			●	●	●	●
<b>OUTPUTS</b>							
USB	●			●	Standard	●	●
USB Key Port	●						
RS-232	●			Optional	Optional		
Analog Output	●	●			●	●	
Ethernet	●			Optional			
<b>EXTERNAL TRIGGER</b>	●			●		●	
<b>FULL STATISTICAL FUNCTIONS</b>	●			●	●	●	●
<b>MAX REPETITION RATE</b>	2 kHz (10 kHz sampling)			10 kHz/Channel		1 kHz	6 kHz
<b>NUMBER OF CHANNELS</b>	1	1	1	1 or 2	1	1	1
<b>PRODUCT PAGE</b>	<b>20</b>	<b>24</b>	<b>26</b>	<b>28</b>	<b>30</b>	<b>32</b>	<b>36</b>

# MAESTRO

Touch Screen, Single Channel, Power & Energy Monitor



\* Every language may not be available yet

## FEATURES

1. **READS ALL HEADS**
  - Power: Thermopiles, Photo Detectors and Pyroelectrics
  - Energy: Thermopiles (in single shot mode), Photo Detectors and Pyroelectrics
2. **LARGE TOUCH SCREEN COLOR LCD DISPLAY**
  - 5.6in Diagonal
  - 640 x 480 Resolution
  - 18bit Color
  - FULLY Touch Screen Controls
3. **UNIQUE ERGONOMIC DESIGN**  
Great for both handheld and tabletop use, with improved rubber bands and kickstand for better stability
4. **INTUITIVE USER INTERFACE**  
Easy to navigate interface, with many display features:
  - Single or Dual Graph Display
  - Instant access to the main functions
  - Function Search tool
  - Interface available in multiple languages
5. **USB KEY ACCESS**  
Store data directly on a USB key
6. **REAL-TIME STATISTICAL FUNCTIONS**  
Max, Min, Average, Standard Deviation, RMS and PTP Stability, Pulse # and Repetition Rate
7. **AVAILABLE OUTPUTS**  
USB Key, Analog Output, RS-232, PC-USB, Ethernet

## CONNECTIVITY



## ACCESSORIES



Additional 9V Power Supply  
(Model Number: 200960)



Battery Pack  
(Model Number: 201013)



USB, RS-232, External Trigger &  
Analog Out Cables



Protective Pouch  
(Model Number: 200128)



Pelican Carrying Case

## PC-GENTEC-EO SOFTWARE

### UNIVERSAL

Compatible with INTEGRA detectors and MAESTRO

### EASY-TO-USE

Clear and concise user interface with attractive graphics and well organized functions

## SEE ALSO

ENERGY DETECTORS	<b>38</b>
POWER DETECTORS	<b>58</b>
HIGH POWER DETECTORS	<b>94</b>
PHOTO DETECTORS	<b>108</b>
THZ DETECTORS	<b>118</b>
OEM DETECTORS	<b>134</b>
LIST OF ALL ACCESSORIES	<b>184</b>

Watch the Introduction video available on our website at [www.gentec-eo.com](http://www.gentec-eo.com)

MONITORS

ENERGY DETECTORS

POWER DETECTORS

HIGH POWER SOLUTIONS

PHOTO DETECTORS

THZ DETECTORS

OEM DETECTORS

SPECIAL PRODUCTS

BEAM DIAGNOSTICS

# MAESTRO



\*Also traceable to NRC-CNRC

## SPECIFICATIONS

### MAESTRO

**DETECTOR TYPES** ALL MODELS: Thermopiles, Pyroelectrics, Photo Detectors

**DISPLAY** Touch Screen 5.6 in Color LCD

#### POWER METER SPECIFICATIONS

Power Range

Thermopile 1  $\mu$ W to 30 kW

Photo Detector 4 pW to 3 W

Monitor Accuracy 0.25 %  $\pm$  5  $\mu$ V best scale

Statistics Current Value, Max, Min, Average, Standard Deviation, RMS & PTP Stability, Time

#### ENERGY METER SPECIFICATIONS

Energy Range 30 fJ to 30 kJ

Monitor Accuracy  $\pm$ 1 % best scale

Software Trigger Level 0.1 to 99.9 %, 0.1 % resolution, default 2 %

Repetition Rate 2 000 Hz / 10 000 Hz in sampling

Real Time Data Transfer (To USB key) 2 000 Hz

Statistics Current Value, Max, Min, Average, Std Dev., RMS & PTP Stability, Pulse #, Rep. Rate and Avg Power

#### DETECTOR COMPATIBILITY

Thermopile Average Power & Single Shot Energy

Photo Detector Average Power & Pulse Energy

Pyroelectric Pulse Energy & Average Power

#### GENERAL SPECIFICATIONS

Interface Languages English, German, French and Japanese (Chinese to come)

Digital Display Size 112.9 x 84.7 mm LCD - 640 x 480 pixels

Data Display Real Time, Scope, Statistics, Digital Tuning Needle and Averaging

Analog Output 0-1 Volt, Full Scale,  $\pm$ 0.5 %

Rising Edge External Trigger TTL Compatible, 2-25 V @ 0.4 mA

Serial Commands Via USB (standard), Ethernet or RS-232 (cable in option)

Internet Upgrades Via USB key

Data Storage Via USB key

Dimensions 210W x 122H x 45D mm

Weight (With Batteries) 0.67 kg

Battery Type 4 x Rechargeable 1.2 V Ni-MH AA

Battery Life 6.5 hours

External Power Supply 100/240 VAC 50-60 Hz to 9 VDC 1.66 A

#### ORDERING INFORMATION

Product Name MAESTRO

Product Number 201235

Specifications are subject to change without notice

# MAESTRO

MONITORS



ENERGY DETECTORS

POWER DETECTORS

HIGH POWER SOLUTIONS

PHOTO DETECTORS

THZ DETECTORS

OEM DETECTORS

SPECIAL PRODUCTS

BEAM DIAGNOSTICS

## HOME

Set Device:	Set all the parameters related to your MAESTRO device.
Set Measure:	Set all the parameters related to your sensor.
Display:	Set the device in Dual or Full Screen display mode and choose the display(s) you want.
Acquisition:	Set all your acquisition parameters (time, sample rate, etc.).
Startup Config:	Choose how your MAESTRO will remember your sensor settings at startup.
About:	View the main parameters and update your MAESTRO.

## SET DEVICE

Use the elements in this menu to set the parameters related to your MAESTRO:

Number of Digits:	Use this menu to set the precision of the measurement.
Serial Commands:	Set compatibility with SOLO2 and use the RS-232, USB and Analog Outputs
Ethernet:	Configure the Ethernet communication protocol.
Languages:	Select the display language: English, German, Japanese or French (Firmware V1.04.02 or higher)





## SET MEASURE

Use the elements in this menu to set everything related to your measurements:

Wavelength:	Select one of the standard wavelengths offered, enter a custom value and create your own list of standard wavelengths.
Range:	Set the measuring range to autoscale or a fixed scale.
Measure Mode:	Use this menu to decide what type of measurements will be displayed: average power, single shot energy, pulse-to-pulse energy, etc.
Corrections:	Enter multipliers and offsets.
Trigger Level:	Set the trigger level in 0.1% steps, from 0.1% and 99.9%.



## DUAL SCREEN DISPLAY (SHOWN WITH SCOPE DISPLAY)

With the Dual Screen mode, the MAESTRO really takes full advantage of its extra-large screen! Any display mode can be used in both single or dual display mode. In dual display mode, the Real Time display takes the upper portion of the screen, while any of the other displays (Scope, Needle, Averaging or Statistics) is set on the lower portion. The display in the lower portion can be easily changed using the parameters bar with drop-down menus in the center of the screen. You can also expand one of the displays to have it in Full Screen mode using the maximize  button. Just as easily, you can go back to Dual Screen display by using the minimize  button.



# MAESTRO

CE NIST\* Traceable  
 \*Also traceable to NRC-CNRC

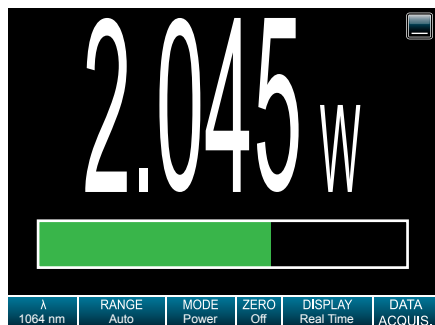

## REAL TIME DISPLAY

This display shows the measured value in real time, with a corresponding bar graph below. The large size of the digits and high contrast of the graphics allow to see the measurement from a good distance. This mode is also always present in dual screen mode, in the upper portion of the screen.

- Very Large Digits
- Bar graph

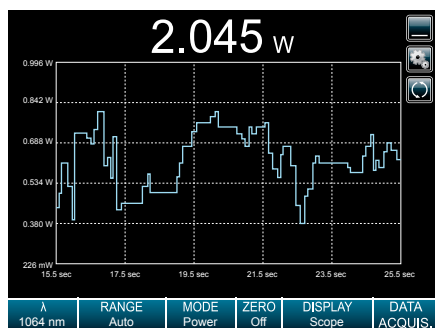

## SCOPE DISPLAY

With its line filling from the right of the screen, in a first-in/first-out manner, this display mode is a good approximation of an actual oscilloscope reading. Settings include time (x-axis) and range (y-axis). Basic statistics can also be displayed directly on the screen.

- Oscilloscope-type graph
- On-screen, real time statistics (min, max and average)
- Fully customizable x and y axis



## NEEDLE DISPLAY

Exactly like an analog needle, only faster! This mode is particularly useful when tuning a laser. The Real Time value is also displayed at the top of the screen.

- Ultra-fast readings
- Great for tuning
- Real Time value at the top of the screen
- Min and Max Values hold

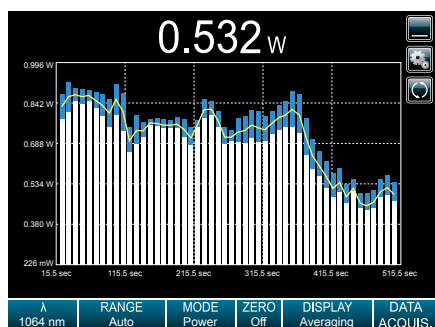

## AVERAGING DISPLAY

This very unique mode is perfect to show the trend of a laser over time. Set the number of points per batch and let the MAESTRO identify the minimum and maximum values of every batch. A yellow curve then follows the average of each batch, displayed as bars on the screen. The wider the difference between the white and blue portions of a bar (corresponding to the min and max values), the more unstable your laser is.

- Calculates the min, max and average values of batches of measurements
- Perfect to check laser stability over time

# TUNER

Single Channel, Power Monitor with Tuning Needle



## FEATURES

- 1. ULTRA-FAST NEEDLE**  
Less than 1 second response time
- 2. READS ALL POWER DETECTORS**  
Thermopiles and photo detectors of the PH100 and PH20 Series
- 3. LARGE LCD DISPLAY**
  - 77 x 58 mm
  - 17.5 mm digits
  - Backlight (with AC adaptor)
- 4. 3 DISPLAY FUNCTIONS FOR THE NEEDLE**
  - Normal
  - Tail Mode (indicates speed)
  - Bar graph

Also HIGH and LOW values hold
- 5. SINGLE-BUTTON NAVIGATION**  
Direct access and long press access to the main functions
- 6. LOW CONSUMPTION**  
Lasts 300 hours with 4 AA alkaline batteries

## DISPLAY MODES

### TAIL:

Follows the speed of the power change. The comet tail is longer for faster reading changes and shorter for slower reading changes.



### BAR GRAPH:

Fills the needle display up to the real time value (best mode when viewing from a distance).



### HIGH/LOW:

When activated, indicates the highest and lowest powers since activation. The high and low needles blink to help distinguish them from the real time value.



## ACCESSORIES



Additional 9V Power Supply  
(Model Number: 200960)



Wall Support  
(Model Number: 201241)



Protective Pouch  
(Model Number: 200128)



Pelican Carrying Case

## SEE ALSO

POWER DETECTORS	58
HIGH POWER DETECTORS	94
PH SERIES PHOTO DETECTORS	110
THZ DETECTORS	118
OEM DETECTORS	134
LIST OF ALL ACCESSORIES	184

# TUNER



\*Also traceable to NRC-CNRC

## SPECIFICATIONS

### TUNER

<b>DETECTOR TYPES</b>	Thermopiles, Photo Detectors (PH Series)
<b>DISPLAY</b>	LCD with Tuning Needle and Backlight

### POWER METER SPECIFICATIONS

Power Range	10 pW to 10 kW
Digital Resolution	
PH Series	10 pW
XLP Series	1 $\mu$ W
UP Series	1 mW
HP Series	100 mW (HP60A), 1 W (HP100A)
Monitor Accuracy	$\pm 1$ %, full scale
Statistics	Min, Max

### DETECTOR COMPATIBILITY

Thermopiles	Average Power (W, dBm)
Photo Detectors (PH Series)	Average Power (W, dBm)

### GENERAL SPECIFICATIONS

Digital Display Size	77 x 58 mm LCD
Needle Display	Ultrafast Tuning Needle
Needle Accuracy	0.9 %
Refresh Rate	4 Hz
Analog Output	0-1 Volt, Full Scale, $\pm 1$ %
Dimensions (Without Stand)	210W x 122H x 44D mm
Weight (With Batteries)	0.47 kg
Battery Type	4 x AA Alkaline
Battery Life (Estimated)	300 hours with detector
External Power Supply	100/240 VAC 50-60 Hz to 9 VDC 1.66 A

### ORDERING INFORMATION

Product Name	TUNER
Product Number	201207

Specifications are subject to change without notice

MONITORS

ENERGY DETECTORS

POWER DETECTORS

HIGH POWER SOLUTIONS

PHOTO DETECTORS

THZ DETECTORS

OEM DETECTORS

SPECIAL PRODUCTS

BEAM DIAGNOSTICS

# UNO

Single Channel, Power Monitor



## FEATURES

1. **READS ALL POWER DETECTORS**  
Thermopiles and photo detectors of the PH Series
2. **LARGE LCD DISPLAY**
  - 76 x 57 mm
  - 32 mm digits
3. **UNIQUE ERGONOMIC DESIGN**  
Great for both handheld and tabletop use
4. **ACCURATE**  
24 bit A/D converter for high resolution measurements
5. **SINGLE-BUTTON NAVIGATION**  
Direct access and long press access to all the functions
6. **EXTREMELY LOW CONSUMPTION**  
Lasts 670 hours with 4 AA alkaline batteries
7. **ECONOMICAL**  
Get the best value for your money with this inexpensive and simple to use power monitor

NOW AVAILABLE

## W/dBm

You can now toggle your display between Watts or dBm units

## ACCESSORIES



Optional 9V Power Supply  
(Model Number: 200960)



Wall Support  
(Model Number: 201241)



Protective Pouch  
(Model Number: 200128)



Pelican Carrying Case

## SEE ALSO

POWER DETECTORS	<b>58</b>
HIGH POWER DETECTORS	<b>94</b>
PHOTO DETECTORS	<b>108</b>
THZ DETECTORS	<b>118</b>
OEM DETECTORS	<b>134</b>
LIST OF ALL ACCESSORIES	<b>184</b>

MONITORS  
ENERGY DETECTORS  
POWER DETECTORS  
HIGH POWER SOLUTIONS  
PHOTO DETECTORS  
THZ DETECTORS  
OEM DETECTORS  
SPECIAL PRODUCTS  
BEAM DIAGNOSTICS

# UNO



\*Also traceable to NRC-CNRC

## SPECIFICATIONS

### UNO

**DETECTOR TYPES** Thermopiles, Photo Detectors (PH Series)

**DISPLAY** LCD

#### POWER METER SPECIFICATIONS

Power Range 5 pW to 10 kW

Thermopile Autoscale

Photo Detector Autoscale

Monitor Accuracy  $\pm 1\%$

Statistics None

#### DETECTOR COMPATIBILITY

Thermopiles Average Power (W, dBm)

Photo Detectors Average Power (W, dBm)

#### GENERAL SPECIFICATIONS

Digital Display Size 76 x 57 mm LCD

Digit Height 32 mm

Digit Type High Contrast Fields

Data Display Real Time

Dimensions (Without Stand) 210W x 122H x 44D mm

Weight (With Batteries) 0.47 kg

Battery Type 4 x AA Alkaline

Battery Life (Estimated) 670 hours with detector

External Power Supply (Optional) 100/240 VAC 50-60 Hz to 9 VDC 1.66 A

#### ORDERING INFORMATION

Product Name UNO

Product Number 200982

Specifications are subject to change without notice

MONITORS

ENERGY DETECTORS

POWER DETECTORS

HIGH POWER SOLUTIONS

PHOTO DETECTORS

THZ DETECTORS

OEM DETECTORS

SPECIAL PRODUCTS

BEAM DIAGNOSTICS

# S-LINK

Dual & Single Channel, PC-Based Power and Energy Monitor



## FEATURES

1. **READS BOTH POWER AND ENERGY**  
Thermopiles and pyroelectrics
2. **AVAILABLE WITH 1 OR 2 CHANNELS**  
S-LINK-1 and S-LINK-2 models now available
3. **PC-BASED**  
Connects to your PC with included software
4. **SERIAL COMMANDS**  
Serial commands are available on all versions to let you take full control
5. **FASTEST DATA TRANSFER RATE**  
Get all the points transferred directly into your PC at 10 kHz/Channel
6. **USB OR ETHERNET**  
Choose your favourite communications port. The USB version is port-powered
7. **EXTERNAL TRIGGER**  
Every model comes standard with a 2.4 V to 24 V external trigger

## AVAILABLE MODELS



S-LINK-1  
(USB)

S-LINK-1  
(Ethernet)

S-LINK-2  
(USB)

S-LINK-2  
(Ethernet)

## ACCESSORIES



Additional 9V Power Supply  
(Model Number: 200960)



USB Cable  
(Model Number: 202373)



Protective Pouch  
(Model Number: 200128)



Pelican Carrying Case

## SEE ALSO

ENERGY DETECTORS	<b>38</b>
POWER DETECTORS	<b>58</b>
HIGH POWER DETECTORS	<b>94</b>
THZ DETECTORS	<b>118</b>
OEM DETECTORS	<b>134</b>
LIST OF ALL ACCESSORIES	<b>184</b>

MONITORS

ENERGY DETECTORS

POWER DETECTORS

HIGH POWER SOLUTIONS

PHOTO DETECTORS

THZ DETECTORS

OEM DETECTORS

SPECIAL PRODUCTS

BEAM DIAGNOSTICS

## S-LINK



\*Also traceable to NRC-CNRC

## SPECIFICATIONS

	S-LINK-1	S-LINK-2	
<b>DETECTOR TYPES</b>	Thermopiles, Pyroelectrics		
<b>CHANNELS / DISPLAY</b>	1-Channel / PC-Based	2-Channels / PC-Based	
<b>POWER METER SPECIFICATIONS</b>			
Power Range	1 $\mu$ W to 10 kW	1 $\mu$ W to 10 kW	
Monitor Accuracy	$\pm 0.75$ % for 25 % to full scale	$\pm 0.75$ % for 25 % to full scale	
Statistics	Current Value, Max, Min, Average, Std Dev., RMS & PTP Stability, Time	Current Value, Max, Min, Average, Std Dev., RMS & PTP Stability, Time	
<b>ENERGY METER SPECIFICATIONS</b>			
Energy Range	30 fJ to 20 kJ	30 fJ to 20 kJ	
Resolution (Digital)	Normal Mode: Current scale/4096	Normal Mode: Current scale/4096	
Monitor Accuracy			
<500 Hz (MB), <1200 Hz (MT)	1 %	1 %	
500 to 1 200 Hz (MB)	2 %	2 %	
1 200 to 6 000 Hz (MT)	3 %	3 %	
6 000 to 10 000 Hz (MT)	6 %	6 %	
Real Time Data Transfer	10 kHz in normal mode, no missing point	10 kHz/Channel in normal mode, no missing point	
Statistics	Current Value, Max, Min, Average, Std Dev., RMS & PTP Stability, Pulse #, Repetition Rate, Average Power		
<b>DETECTOR COMPATIBILITY</b>			
Thermopile	Average Power & Single Shot Energy	Average Power & Single Shot Energy	
Pyroelectric	Pulse Energy	Pulse Energy	
<b>GENERAL SPECIFICATIONS</b>			
Number of Channels	1	2	
Digital Display	Computer Screen	Computer Screen	
Data Display	Real Time, Ratio, Line Plot, Histogram, Statistics and 3D Histogram	Real Time, Ratio, Line Plot, Histogram, Statistics and 3D Histogram	
Serial Commands and Data Transfer Via	USB (standard) or Ethernet (option) <sup>a</sup>	USB (standard) or Ethernet (option) <sup>a</sup>	
Real Time Data Transfer Rate	10 kHz/Channel in normal mode, no missing point (for pyroelectrics only) <sup>b</sup>	10 kHz/Channel in normal mode, no missing point (for pyroelectrics only) <sup>b</sup>	
Rising Edge External Trigger	3-24 V @ 13 mA, optically isolated	3-24 V @ 13 mA, optically isolated	
Dimensions	106W x 34H x 147D mm	106W x 34H x 147D mm	
Weight	0.424 kg	0.424 kg	
Ext. Power Supply (Ethernet version only)	100/240 VAC 50-60 Hz to 9 VDC 1.66 A	100/240 VAC 50-60 Hz to 9 VDC 1.66 A	
<b>ORDERING INFORMATION</b>			
	1 channel	1 channel	2 channels
Product Name	S-LINK-1	S-LINK-1 (Ethernet) <sup>a</sup>	S-LINK-2
Product Number	202225	202226	201030

Specifications are subject to change without notice

a. The Ethernet version also includes the USB output.

b. Actual rate may depend on the computer.

# P-LINK

1 and 4 Channels, PC-Based Power Monitors



## FEATURES

1. **READS ALL POWER DETECTORS TYPES**  
Thermopiles and photo detectors of the PH Series
2. **PC-BASED**  
Connects to your PC with included software
3. **MULTI-CHANNEL CAPABILITIES**  
Available with 1 or 4 channels
4. **SERIAL COMMANDS**  
Serial commands are available on both versions to let you take full control
5. **REAL-TIME STATISTICAL FUNCTIONS**  
Max, Min, Average, Standard Deviation, RMS and PTP Stability. Also High Low Alarm and Post-Analysis Mode (P-LINK-4 only)
6. **USB, RS-232 OR ETHERNET**  
Choose your favourite communications port. The USB version is port-powered. Ethernet available only on 4-Channel version

## AVAILABLE MODELS



P-LINK (USB)



P-LINK (RS-232)



P-LINK-4

## ACCESSORIES



Additional 9V Power Supply  
(RS-232 version only)



USB & RS-232 Cables



Protective Pouch  
(Model Number: 200128)



Pelican Carrying Case

## SEE ALSO

POWER DETECTORS	<b>58</b>
HIGH POWER DETECTORS	<b>94</b>
PHOTO DETECTORS	<b>108</b>
THZ DETECTORS	<b>118</b>
OEM DETECTORS	<b>134</b>
LIST OF ALL ACCESSORIES	<b>184</b>

# P-LINK



\*Also traceable to NRC-CNRC

## SPECIFICATIONS

	P-LINK		P-LINK-4	
<b>DETECTOR TYPES</b>	Thermopiles, Photo Detectors		Thermopiles, Photo Detectors	
<b>CHANNELS / DISPLAY</b>	1-Channel / PC-Based		4-Channel / PC-Based	
<b>POWER METER SPECIFICATIONS</b>				
Power Range				
Thermopile	3 $\mu$ W to 30 kW		3 $\mu$ W to 30 kW	
Photo Detector	1 pW to 3 W		1 pW to 3 W	
Monitor Accuracy	$\pm 0.5$ % full scale		$\pm 0.5$ % full scale	
Statistics	<sup>a</sup> Current Value, Max, Min, Average, Std Dev., RMS & PTP Stability, Time		<sup>b</sup> Current Value, Max, Min, Average, Std Dev., RMS & PTP Stability, Time	
<b>DETECTOR COMPATIBILITY</b>				
Thermopile	Average Power & Single Shot Energy		Average Power	
Photo Detector	Average Power (mW, dBm)		Average Power (mW)	
<b>GENERAL SPECIFICATIONS</b>				
Number of Channels	1		4	
Digital Display	Computer Screen		Computer Screen	
Data Display	<sup>a</sup> Real Time, Histogram, Statistics, Digital Tuning Needle		<sup>b</sup> Real Time, Graphic, Statistics, High/Low Alarm, Post-Analysis Mode, Multi-Channel	
Analog Output	0 - 2 Volt, Adjustable, Full Scale, $\pm 1$ %		N/A	
Serial Commands and Data Transfer Via	USB (standard) or RS-232 (option)		USB (standard) or Ethernet (option)	
Real Time Data Transfer Rate	10 Hz		10 Hz	
Dimensions	57W x 26H x 91D mm		286W x 233H x 43D mm	
Weight	0.12 kg		2.5 kg	
External Power Supply (RS-232 and Ethernet versions only)	100/240 VAC 50-60 Hz to 12 VDC 200 mA		100/240 VAC 50-60 Hz to 9-12 VDC 100 mA	
<b>ORDERING INFORMATION</b>				
	1 Channel	1 Channel	4 Channels	4 Channels
Product Name	P-LINK (USB)	P-LINK (RS-232)	P-LINK-4 (USB)	P-LINK-4 (Ethernet)
Product Number	200439	200440	202223	202224

Specifications are subject to change without notice

a. Using PC-LINK software.

b. Using Octolink software.

# M-LINK

Single Channel, PC-Based Universal Power and Energy Monitor



## AVAILABLE MODELS

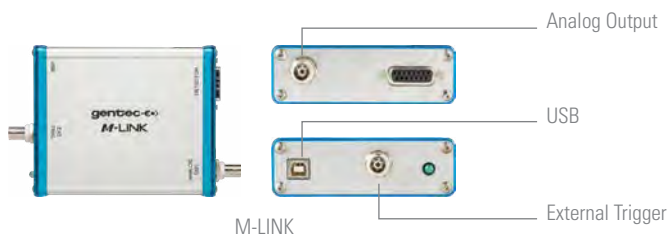

## ACCESSORIES



USB Cable

(Model Number: 202373)



Pelican Carrying Case

## FEATURES

- 1. THE UNIVERSAL PC-BASED METER**  
Reads ALL Heads:
  - Power: Thermopiles, Photo Detectors and Pyroelectrics
  - Energy: Thermopiles (in single shot mode), Photo Detectors and Pyroelectrics
- 2. MEASURE fJ ENERGY LEVELS**  
Thanks to a unique digital method for suppressing the noise on the lower ranges
- 3. EXTERNAL TRIGGER**  
Synchronize your M-LINK to your pulsed laser or digital chopper
- 4. DIGITAL (USB) OUTPUT**  
Connect the M-LINK module directly to your PC
- 5. POWERFUL LABVIEW SOFTWARE**  
Features include:
  - Complete instrument controls: Range, Trigger, Wavelength, etc.
  - Live display in J and J/cm<sup>2</sup> or W and W/cm<sup>2</sup>
  - Full Statistics: Min, Max, Mean, Standard Deviation, RMS Stability, Repetition Rate, etc.
  - Graphic Displays: Strip Chart, Histogram, Tuning Needle and more
  - Data File Collection and Analysis

## SEE ALSO

ENERGY DETECTORS	38
POWER DETECTORS	58
HIGH POWER DETECTORS	94
PHOTO DETECTORS	108
THZ DETECTORS	118
LIST OF ALL ACCESSORIES	184

Watch the video available on our website at

[www.gentec-eo.com](http://www.gentec-eo.com)

# M-LINK



\*Also traceable to NRC-CNRC

## SPECIFICATIONS

### M-LINK

**DETECTOR TYPES** ALL MODELS: Thermopiles, Pyroelectrics, Photo Detectors

**DISPLAY** PC-Based

#### POWER METER SPECIFICATIONS

Power Range 4 pW to 30 kW

Resolution (Digital) Current Scale/3000

Monitor Accuracy  $\pm 0.5\% \pm 2$  digits

Statistics Current Value, Max, Min, Average, Std Dev., RMS & PTP Stability, Time

#### ENERGY METER SPECIFICATIONS

Energy Range 30 fJ to 30 kJ

Resolution (Digital) Current Scale/3000

Monitor Accuracy  $1\% \pm 2$  digits (<1 kHz)

Software Trigger Level 0.1 to 99.9%, 0.1% resolution, default 2%

Repetition Rate<sup>a</sup> 1 000 Hz

Real Time Data Transfer 1 000 Hz with time stamp, no missing point

Statistics Current Value, Max, Min, Average, Std Dev., RMS & PTP Stability, Pulse #, Repetition Rate, Average Power

#### DETECTOR COMPATIBILITY

Thermopile Average Power & Single Shot Energy

Pyroelectric Pulse Energy & Average Power

Photo Detectors Average Power & Pulse Energy

#### GENERAL SPECIFICATIONS

Digital Display Computer Screen

Data Display Real Time, Scope, Averaging, Statistics and Digital Tuning Needle

Serial Commands and Data Transfer Via USB

Real Time Data Transfer Rate 1 000 Hz with time stamp, no missing point (for pyroelectrics only)

Analog Output 0-2 Volts, Full Scale,  $\pm 2\%$  (joulemeters)  $\pm 4\%$  (wattmeters)

Rising or Falling Edge External Trigger 4.5 to 10 V @ 20 mA, optically isolated

Dimensions 106W x 34H x 147D mm

Weight 0.424 kg

#### ORDERING INFORMATION

Product Name M-LINK

Product Number 201850

Specifications are subject to change without notice

a. Maximum repetition rate may vary with PC and detector speeds.

# M-LINK



## PC-BASED UNIVERSAL POWER/ENERGY MONITOR

This PC-Based monitor is compatible with ALL types of detectors - including thermopiles, pyroelectrics and photo detectors - for both power and energy measurements. The device is available as a single channel unit that directly interfaces with a computer using a USB2.0 connection. The LabView software is included and comes with all the necessary features. The M-LINK also presents a unique digital technique of suppressing the noise, thereby extending the measurement range all the way down to the fJ level.

## VERSATILE SOFTWARE FOR THE UNIVERSAL M-LINK

What makes the M-LINK so universal is its compatibility with every detector type and model we make, and our smart software that recognizes the type of detector attached, and configures itself accordingly. Some of the basic software features include:

- Live Digital Reading
- Full Statistics
- Strip Chart
- Histogram
- Analog Tuning
- Data Logging



## MEASURE POWER WITH A PHOTO DETECTOR

If you need to measure low power levels, from pW to mW, then we recommend one of our PH or PH-B detectors. In the software screen shown on the left, we have taken a data set working in the **“STATS”** display mode. We have set the batch size to 100 data points in the manual reset mode. You can see the live power (138 nW) and full complement of statistics: mean, max, min, RMS and PTP stability. In the bottom left hand corner you will note that a wavelength of 300 nm is displayed. This is where you will enter the wavelength of your laser and engage the wavelength correction factor.



## MEASURE POWER WITH A THERMOPILE DETECTOR

You can select any of our Thermal Detectors to measure your laser power from a few  $\mu\text{W}$  up to 30 kW. We used one of our most sensitive thermopile detectors, model XLP12-3S-H2, to generate the software screen shown on the left. We have selected the **“SCOPE”** mode, where you can view the live power reading (0.404 W), a bar graph and a strip chart while monitoring the power. This high level screen also provides access to range, trigger, auto scale, and many other monitor functions.

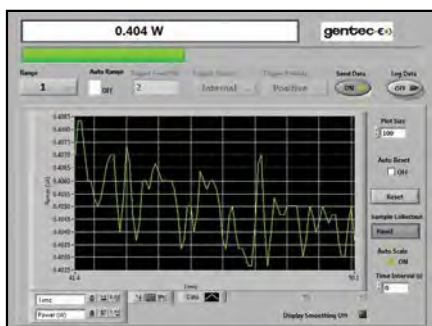

## M-LINK

CE NIST\*  
Traceable



\*Also traceable to NRC-CNRC

## MEASURE POWER WITH A PYROELECTRIC DETECTOR

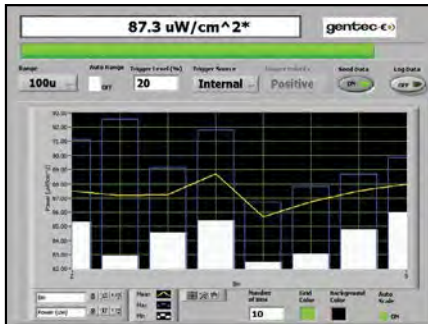

Need to measure the Radiant Flux (Watts) or Irradiance ( $W/cm^2$ ) of a broadband source like the sun, a lamp, a temperature controlled black body and/or a mid or far-IR laser? Our broadband pyroelectric detectors of the UM-B Series would be a great choice. To make the measurement that is displayed on the left, we set up our UM9B-BL detector with M-LINK, an SDC-500 Chopper running 10 Hz and our 725 °C Black Body Source. The M-LINK recognizes the UM9B-BL detector, sets the wavelength to 633 nm where it is calibrated and prepares it to measure the voltage square wave it generates. We have engaged the area correction as the 9 mm detector is over filled with radiation. We are therefore measuring Irradiance in  $W/cm^2$ .

## MEASURE ENERGY WITH A PYROELECTRIC DETECTOR



You can select one of our many large area Pyroelectric Detectors of the QE Series for energy measurements ranging from 50 nJ to 250 J and from DUV to Far IR. To demonstrate this capability, we have selected our QE8SP-B-BL and the M-LINK. We are looking at the **"HISTOGRAM"** screen, where you can continue to view the live measurement and a histogram that shows the energy distribution of your data set, along with a best-fit Gaussian curve. Note that you still have access to the instrument controls, like range, trigger, wavelength, etc.

## MEASURE AT THE fJ LEVEL WITH A PE-B DETECTOR



For measurements in the fJ to  $\mu J$  range, and from UV to Near-IR we suggest our PE3B-Si detector. It represents the state-of-the-art in low-end energy detector technology. Take advantage of our proprietary pulse averaging, noise reduction techniques available with M-LINK. In the example shown at the right, we have captured a data set while running in the **"AVERAGING"** mode. The bars represent minimum (white) and maximum (blue) energy values. The strip chart is based on the average energy value. You get to select the number of "BINS" represented here. "Pulse Averaging" is available in the Statistics screen.

## MEASURE A HIGH ENERGY PULSE WITH A UP DETECTOR

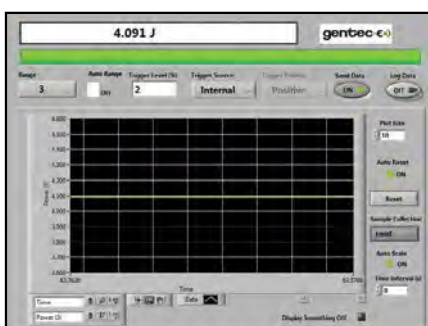

If you are trying to measure a relatively high energy (Joules) single pulse (up to 300 msec long), you will select one of our Thermopile Power detectors (like the UP50-W9), have it calibrated in single shot mode and use the M-LINK to make the measurement. In the screen at the right, we have captured a long pulse that had a duration of a few hundred milliseconds and are displaying the energy in the **"SCOPE"** screen. Using a variety of our thermopile detectors, you can measure from 12  $\mu J$  to 500 J in a single pulse.

MONITORS

ENERGY DETECTORS

POWER DETECTORS

HIGH POWER SOLUTIONS

PHOTO DETECTORS

THz DETECTORS

OEM DETECTORS

SPECIAL PRODUCTS

BEAM DIAGNOSTICS

# INTEGRA

Embedded Monitor



## FEATURES

1. **ALL-IN-ONE DETECTOR + METER**  
Plug your detectors directly into your PC with the INTEGRA embedded monitor
2. **INCREDIBLE PERFORMANCE**  
INTEGRA detectors offer the same performance as the usual detector + monitor combination
3. **COMPACT SIZE**  
Perfect for the lab, OEM applications and field servicing. No need to carry a meter!
4. **LOWER RECALIBRATION COSTS**  
One Product = One Calibration. Reduce your recalibration costs by half!
5. **UNIVERSAL SOFTWARE-PC-GENTEC-EO**  
Control your INTEGRA detector with the same powerful software as the MAESTRO

WATCH OUT FOR THIS LOGO!

AVAILABLE WITH



## PC-GENTEC-EO SOFTWARE

### UNIVERSAL

Compatible with INTEGRA, MAESTRO, P-LINK and HP

### EASY-TO-USE

Clear and concise user interface with attractive graphics and well organized functions



## SEE ALSO

ENERGY DETECTORS	<b>38</b>
POWER DETECTORS	<b>58</b>
HIGH POWER DETECTORS	<b>94</b>
PHOTO DETECTORS	<b>108</b>

MONITORS

ENERGY DETECTORS

POWER DETECTORS

HIGH POWER SOLUTIONS

PHOTO DETECTORS

THZ DETECTORS

OEM DETECTORS

SPECIAL PRODUCTS

BEAM DIAGNOSTICS

# PC-GENTEC-EO

UNIVERSAL SOFTWARE FOR **INTEGRA, MAESTRO, P-LINK AND HP**

## MAIN CONTROLS

Complete and easily navigable software interface with all the necessary options and tools:

- Connection:** Connect or Disconnect your device.
- Controls:** Turn the Turbo Mode ON or OFF, make a Zero to remove the thermal offset, start the Acquisition of the data and start the calculations of the Statistics associated with this data.
- Startup Config:** Save your measurements settings or Load the settings associated with an already existing file.
- Help:** Get information about the PC-Gentec-EO software and read the user manual.
- Measure:** Configure the parameters related to your measurements.
- Display:** Set the desired number of digits and settings associated with the selected display.
- Acquisition:** Enter the parameters related to the acquisition of data.



## MEASUREMENT PARAMETERS

The Measure tab allows you to configure the parameters related to your measurements:

- Wavelength:** Enter the Wavelength of your laser and the software will apply the appropriate correction factor on the measurements.
- Range:** Set the power or energy Range to a fixed scale or let the software automatically adjust the scale.
- Measure Mode:** Select the type of Measurement that will be displayed (power, energy) and let the software know if you want Anticipation and if there is any Attenuation.
- Corrections:** Apply a Multiplication Factor and/or an Offset to your measurements.
- Trigger Level:** Set the Trigger Level in 0.1% steps, from 0.1% to 99.9% (in energy mode only).



## MULTIPLE DISPLAYS

Select the display that suits you best and watch your measurements in real time! With the options toolbar in the bottom of the interface, you can manage the displays at your convenience:



- Real Time:** Real time value and corresponding bar graph
- Scope:** Line filling graph
- Needle:** Fast analog-like needle
- Averaging:** Shows trend of laser over time
- Histogram:** Displays up to 100 bars
- Statistics:** Min, Max, Average, RMS and PTP Stability, Rep. Rate and Standard Deviation

## DATA ACQUISITION

The Acquisition tab allows you to enter the parameters for data acquisition:

- Power Mode:** Choose a Sampling Rate (number of measurements per interval of time), a Total Duration (in days, hours, minutes and seconds) for the data acquisition, a Time Stamp for each value and the File Name and File Location. You can choose to save only the raw data and/or the statistics associated with your data acquisition.
- Energy Mode:** Choose a sampling rate (1 pulse out of X pulses), a total duration (total number of pulses) for the acquisition of data, a timestamp for each value, the file name and file location. Decide if you want to save raw data and/or the statistics associated with this data.

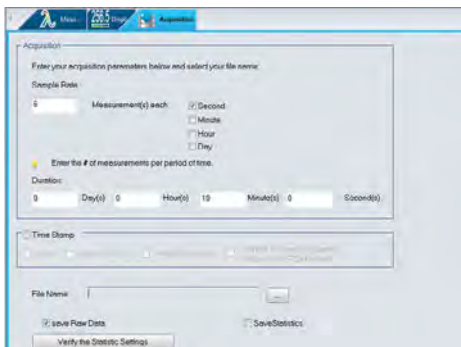

# PRESENTATION

## OVERVIEW OF THE DIFFERENT MODELS

Our pyroelectric energy meters cover a very wide range, going from nanojoules to several tens of joules per pulse. We also have them either in standalone formats, where the electronics are integrated in the device, or as standard sensors that you hook up to an energy meter.

Available with

integra



### QE-B

- Small Compact Detectors
- 8 mm Ø Aperture
- Organic Black or Metallic Coatings with Spectral Ranges from DUV to Far-IR
- Noise Levels as low as 50 nJ, without the need of a photo detector.

COMPACT PYROELECTRIC DETECTORS

NOISE LEVEL AS LOW AS 50 nJ

See page **42**

Available with

integra

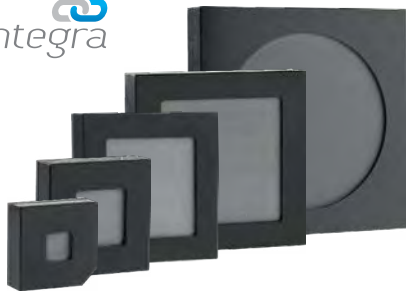

### QE-MB

- Standard (Broadband) Coating
- Available in 5 sizes:
  - 12 x 12 mm 65 x 65 mm
  - 25 x 25 mm 95 mm Ø
  - 50 x 50 mm
- Low Noise Levels and Possibility to Extend the Response for Long (ms) Pulses

STANDARD COATING, LONG PULSE CAPABILITY

See pages **44 to 52**

Available with

integra



### QE-MT

- Metallic (High Repetition Rate) Coating
- Available in 3 sizes:
  - 12 x 12 mm
  - 25 x 25 mm
  - 50 x 50 mm

- Pulse-to-Pulse Response up to 6000 Hz

METALLIC COATING, HIGH REP RATES

See pages **44 to 48**

### 200 kHz MACH 6

- High Speed Digital Joulemeter:
  - Mach 6: Measures EVERY PULSE at 200 kHz
- Capture and Store up to 4 Million Pulses at the Maximum Repetition Rate
- Track Missing Pulses and Pulses below Threshold
- Wide Energy Range: Measure from pJ to mJ

200 kHz ENERGY METER

See our  
Special Products Section  
for more details.

See page **144**



# QED ATTENUATOR

## DESCRIPTION

The QED attenuators increase the energy, energy density, average power and average power density capabilities of the QE Series detectors. They are engineered to typically transmit 30-50% (@1.064  $\mu\text{m}$ )<sup>a</sup> of the incident radiation to the detector in a near Lambertian pattern (very wide diffusion pattern). Their slide-in casing make them easy to install and remove and they are held securely in place with the use of simple set screws. Since they become part of the detector, it is important to understand how they will affect the calibration.

For UV applications, we offer the QEAS attenuator that covers the 190 to 300 nm range. This model is available on demand and in 2 sizes: 25 and 50 mm.

## CALIBRATION OPTIONS

When buying a QE detector with a QED attenuator, 3 calibration options are available:

### STANDARD CALIBRATION

QE Detector Alone:	Fully calibrated, from 0.25 - 2.5 $\mu\text{m}$
With QED Attenuator:	Not calibrated (Calibrated by the user)



### CALIBRATED AS A PAIR (-QED EXTENSION)

QE Detector Alone:	Not calibrated
With QED Attenuator:	Fully calibrated, from 0.3 - 2.1 $\mu\text{m}$



### EXTRA QED CALIBRATION

QE Detector Alone:	Fully calibrated, from 0.25 - 2.5 $\mu\text{m}$
With QED Attenuator:	Calibrated at one wavelength (532 nm or 1064 nm)



## SPECIFICATIONS

PHYSICAL CHARACTERISTICS	QED-12	QED-25	QED-50	QED-65	QED-95	QEAS-25*	QEAS-50*
Spectral Range	300 - 2100 nm	300 - 2100 nm	300 - 2100 nm	300 - 2100 nm	300 - 2100 nm	190 - 300 nm	190 - 300 nm
Effective Aperture	9 x 9 mm	22 x 22 mm	47 x 47 mm	62 x 62 mm	90 mm $\varnothing$	22 x 22 mm	47 x 47 mm
Dimensions	30.5H x 41W x 12.5D mm	44H x 55W x 12.5D mm	69H x 80W x 12.5D mm	85H x 97W x 12.5D mm	115H x 127W x 12.5D mm	52.5H x 55W x 15.5D mm	77.5H x 80W x 15.5D mm
For use with	QE12	QE25	QE50	QE65	QE95	QE25	QE50

### ORDERING INFORMATION<sup>b,c</sup>

Product Name (QED alone)	QED-12	QED-25	QED-50	QED-65	QED-95	QEAS-25	QEAS-50
Product Number	201200	201199	201198	201282	201323	200316	200317

a. See the full transmittance curve on page 56

b. For ordering information about the detectors, check the product pages.

c. Ordering information of the QE-QED kits calibrated as a pair can be found on the individual specifications sheets of the QE products.

\* This attenuator comes uncalibrated

## COMPARISON TABLE

 Available with INTEGRA all-in-one detector + meter

MODEL	EMAX*	NOISE LEVEL	P <sub>MAX</sub>	λ <sub>MIN</sub>	λ <sub>MAX</sub>	MAX REP RATE	ABSORBER TYPE	APERTURE	SEE PAGE
QE8SP-B-MT	1.3 mJ	50 nJ	500 mW	190 nm	20 μm	1000 Hz	Metallic	7.8 x 7.8 mm	42
QE8SP-B-BL	3.6 mJ	100 nJ	500 mW	190 nm	20 μm	400 Hz	Black	7.8 x 7.8 mm	42
QE12SP-S-MT	700 mJ	800 nJ	3 W	190 nm	20 μm	6000 Hz	Metallic	12 x 12 mm	44
QE12SP-H-MT	700 mJ	800 nJ	5 W	190 nm	20 μm	6000 Hz	Metallic	12 x 12 mm	44
QE12LP-S-MB	850 mJ	700 nJ	3 W	190 nm	20 μm	300 Hz	Broadband	12 x 12 mm	44
QE12LP-H-MB	850 mJ	700 nJ	5 W	190 nm	20 μm	300 Hz	Broadband	12 x 12 mm	44
QE12SP-S-MT + QED-12	1.6 J	25 μJ	7.5 W	308 nm	2.1 μm	6000 Hz	Metallic	9 x 9 mm	44
QE12SP-H-MT + QED-12	1.6 J	25 μJ	12.5 W	308 nm	2.1 μm	6000 Hz	Metallic	9 x 9 mm	44
QE25SP-S-MT	3 J	2 μJ	5 W	190 nm	20 μm	6000 Hz	Metallic	25 x 25 mm	46
QE25SP-H-MT	3 J	2 μJ	10 W	190 nm	20 μm	6000 Hz	Metallic	25 x 25 mm	46
QE25LP-S-MB	3.8 J	4 μJ	5 W	190 nm	20 μm	300 Hz	Broadband	25 x 25 mm	46
QE25LP-H-MB	3.8 J	4 μJ	10 W	190 nm	20 μm	300 Hz	Broadband	25 x 25 mm	46
QE12LP-S-MB + QED-12	3.9 J	3 μJ	7.5 W	308 nm	2.1 μm	300 Hz	Broadband	9 x 9 mm	44
QE12LP-H-MB + QED-12	3.9 J	3 μJ	12.5 W	308 nm	2.1 μm	300 Hz	Broadband	9 x 9 mm	44
QE25SP-S-MT + QED-25	10 J	6 μJ	15 W	308 nm	2.1 μm	6000 Hz	Metallic	22 x 22 mm	46
QE25SP-H-MT + QED-25	10 J	6 μJ	30 W	308 nm	2.1 μm	6000 Hz	Metallic	22 x 22 mm	46
QE50SP-S-MT	13 J	10 μJ	10 W	190 nm	20 μm	4000 Hz	Metallic	50 x 50 mm	48
QE50SP-H-MT	13 J	10 μJ	20 W	190 nm	20 μm	4000 Hz	Metallic	50 x 50 mm	48
QE50LP-S-MB	15 J	10 μJ	10 W	190 nm	20 μm	200 Hz	Broadband	50 x 50 mm	48
QE50LP-H-MB	15 J	10 μJ	20 W	190 nm	20 μm	200 Hz	Broadband	50 x 50 mm	48
QE25LP-S-MB + QED-25	23 J	15 μJ	15 W	308 nm	2.1 μm	300 Hz	Broadband	22 x 22 mm	46
QE25LP-H-MB + QED-25	23 J	15 μJ	30 W	308 nm	2.1 μm	300 Hz	Broadband	22 x 22 mm	46
QE65LP-S-MB	25 J	10 μJ	12 W	190 nm	20 μm	100 Hz	Broadband	65 x 65 mm	50
QE65LP-H-MB	25 J	10 μJ	40 W	190 nm	20 μm	100 Hz	Broadband	65 x 65 mm	50
QE65ELP-S-MB	25 J	20 μJ	12 W	190 nm	20 μm	20 Hz	Broadband	65 x 65 mm	50
QE65ELP-H-MB	25 J	20 μJ	40 W	190 nm	20 μm	20 Hz	Broadband	65 x 65 mm	50
QE95LP-S-MB	35 J	15 μJ	20 W	190 nm	20 μm	40 Hz	Broadband	95 mm Ø	52
QE95LP-H-MB	35 J	15 μJ	40 W	190 nm	20 μm	40 Hz	Broadband	95 mm Ø	52
QE95ELP-S-MB	35 J	30 μJ	20 W	190 nm	20 μm	10 Hz	Broadband	95 mm Ø	52
QE95ELP-H-MB	35 J	30 μJ	40 W	190 nm	20 μm	10 Hz	Broadband	95 mm Ø	52
QE50SP-S-MT + QED-50	44 J	30 μJ	25 W	308 nm	2.1 μm	4000 Hz	Metallic	47 x 47 mm	48
QE50SP-H-MT + QED-50	44 J	30 μJ	45 W	308 nm	2.1 μm	4000 Hz	Metallic	47 x 47 mm	48
QE50LP-S-MB + QED-50	85 J	30 μJ	25 W	308 nm	2.1 μm	200 Hz	Broadband	47 x 47 mm	48
QE50LP-H-MB + QED-50	85 J	30 μJ	45 W	308 nm	2.1 μm	200 Hz	Broadband	47 x 47 mm	48
QE65LP-S-MB + QED-65	125 J	30 μJ	30 W	308 nm	2.1 μm	100 Hz	Broadband	62 x 62 mm	50
QE65LP-H-MB + QED-65	125 J	30 μJ	90 W	308 nm	2.1 μm	100 Hz	Broadband	62 x 62 mm	50
QE95LP-S-MB + QED-95	150 J	45 μJ	45 W	308 nm	2.1 μm	40 Hz	Broadband	90 mm Ø	52
QE95LP-H-MB + QED-95	150 J	45 μJ	90 W	308 nm	2.1 μm	40 Hz	Broadband	90 mm Ø	52

\* at 1064 nm, 7 ns, 10 Hz

MONITORS

ENERGY DETECTORS

POWER DETECTORS

HIGH POWER SOLUTIONS

PHOTO DETECTORS

THZ DETECTORS

OEM DETECTORS

SPECIAL PRODUCTS

BEAM DIAGNOSTICS

# COMPARISON TABLE

## ENERGY RANGES

You can use the graph below to compare the energy ranges of our pyroelectric energy detectors. Ranges go from the noise level to the maximum energy reading (including attenuator when available).

Table 1.  
Comparison of the energy ranges of the pyroelectric energy detectors

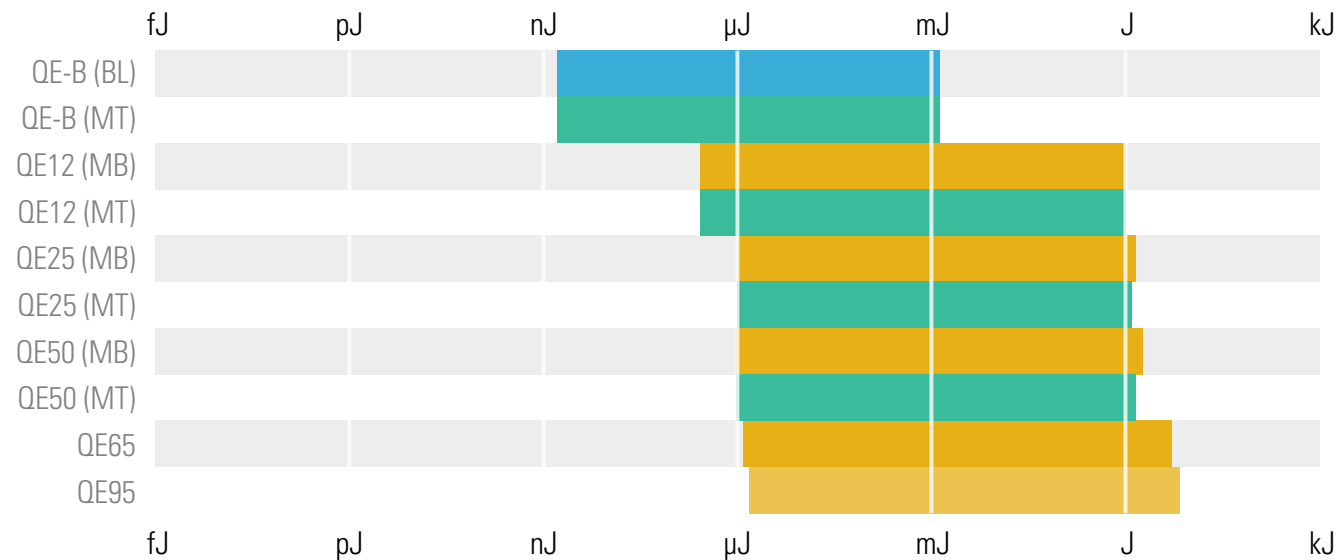

**Black Absorber**  
(Low Rep Rates, Up to 400 Hz)

**Metallic Absorber**  
(High Rep Rates, Up to 6000 Hz)

**Broadband Absorber**  
(Low Rep Rates, Up to 300 Hz + Long Pulses, Up to 5 ms)

- MONITORS
- ENERGY DETECTORS
- POWER DETECTORS
- HIGH POWER SOLUTIONS
- PHOTO DETECTORS
- THZ DETECTORS
- OEM DETECTORS
- SPECIAL PRODUCTS
- BEAM DIAGNOSTICS



# QE-B

50 nJ - 3.6 mJ, Ultra-Low Energy Measurements



## KEY FEATURES

- 1. VERY LOW NOISE LEVELS**  
Noise levels of a photo detector, but with the high energies of a pyroelectric:
  - 50 nJ with the MT coating
  - 100 nJ with the BL coating
- 2. 2 COATINGS AVAILABLE**
  - BL: Black coating, sensitivity of 900 V/J, readings up to 400 Hz
  - MT: Metallic coating, sensitivity of 2400 V/J, readings up to 1000 Hz
- 3. SMART INTERFACE**  
Containing all the calibration data

## AVAILABLE MODELS



QE8SP-B-BL  
(8 mm-Organic Black)



QE8SP-B-MT  
(8 mm-Metallic)

## ACCESSORIES



Stand with Delrin Post  
(Model Number: 200428)



APM Analog Power Supply  
(Model Number: 201848)



Pelican Carrying Case

## SEE ALSO

TECHNICAL DRAWINGS	54
ABSORPTION CURVES	56
COMPATIBLE MONITORS	
MAESTRO	20
S-LINK	28
M-LINK	32
LIST OF ALL ACCESSORIES	184

## APPLICATION NOTES

MEASUREMENT LIMITS USING JOULEMETERS	<a href="#">201932</a>
LONG PULSE JOULEMETER IN BURST MODE	<a href="#">202153</a>

## QE-B

## SPECIFICATIONS

	QE8SP-B-BL	QE8SP-B-MT
<b>MAX MEASURABLE ENERGY</b>	3.6 mJ	1.3 mJ
<b>MAX REPETITION FREQUENCY</b>	400 Hz	1 000 Hz
<b>EFFECTIVE APERTURE</b>	7.8 X 7.8 mm	7.8 X 7.8 mm
<b>MEASUREMENT CAPABILITY</b>		
Spectral Range *	0.19 - 20 $\mu$ m	0.19 - 20 $\mu$ m
Max Measurable Energy		
With M-LINK	3.6 mJ	1.3 mJ
With S-LINK	2.9 mJ	1.1 mJ
With MAESTRO	2.5 mJ	0.93 mJ
Noise Equivalent Energy		
With M-LINK (with noise suppression) <sup>a</sup>	100 nJ (N/A)	50 nJ (3 nJ)
With S-LINK	100 nJ	50 nJ
With MAESTRO	150 nJ	80 nJ
Sensitivity	900 V/J	2400 V/J
Max Repetition Frequency	400 Hz	1000 Hz
Max Pulse Width	10 $\mu$ s	10 $\mu$ s
Rise Time (0-100%)	30 $\mu$ s	30 $\mu$ s
Calibration Uncertainty	$\pm$ 4.0%	$\pm$ 4.0%
Repeatability	<0.5 %	<0.5 %
<b>DAMAGE THRESHOLDS</b>		
Maximum Average Power	0.5 W	0.5 W
Maximum Average Power Density		
1064 nm, 7 ns, 10 Hz	1 W/cm <sup>2</sup>	1 W/cm <sup>2</sup>
Maximum Energy Density		
1064 nm, 7 ns, 10 Hz	50 mJ/cm <sup>2</sup>	50 mJ/cm <sup>2</sup>
<b>PHYSICAL CHARACTERISTICS</b>		
Effective Aperture	7.8 x 7.8 mm	7.8 x 7.8 mm
Absorber	Organic Black	Metallic
Dimensions	38.1 $\varnothing$ X 27.4D mm	38.1 $\varnothing$ X 27.4D mm
Weight	91 g	91 g
<b>ORDERING INFORMATION</b>		
Product Name	QE8SP-B-BL	QE8SP-B-MT
Product Number (Including stand)	202104	202101
 Add Extension for INTEGRA	-INT	-INT

Specifications are subject to change without notice

\* For the calibrated spectral range, see the user manual.

a. Obtain a lower noise level using the Noise Suppression function in the PC M-LINK application. Setting the sampling size at 128 will get the lowest noise level possible.

\* For details, contact your Gentec-EO representative



# QE12

12 x 12 mm, 0.7  $\mu$ J - 3.9 J



## KEY FEATURES

- 1. MODULAR CONCEPT**  
Increase the power capability of your detector:  
2 different cooling modules
- 2. LOW NOISE LEVEL**  
0.7  $\mu$ J for the MB coating
- 3. QED ATTENUATOR AVAILABLE**
  - Measure up to 5X higher energies
  - Available with optional calibration, all wavelengths between 532 & 1064 nm, or single wavelength
- 4. AVAILABLE WITH METALLIC ABSORBER**  
High Repetition Rate (6000 Hz)
- 5. TEST TARGET INCLUDED**  
With the MB models
- 6. SMART INTERFACE**  
Containing all the calibration data

## AVAILABLE MODELS



QE12LP-S-MB  
(Broadband-Convection)



QE12LP-H-MB  
(Broadband-Heatsink)



QE12SP-S-MT  
(Metallic-Convection)



QE12SP-H-MT  
(Metallic-Heatsink)

## ACCESSORIES



Stand with Delrin Post  
(Model Number: 200428)



DB-15 to BNC Adaptor  
(Model Number: 200036)

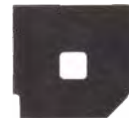

QE12 Attenuator  
(Model Number: 201200)



Pelican Carrying Case

## SEE ALSO

HOW IT WORKS	12
CALIBRATION	6
TECHNICAL DRAWINGS	54
ABSORPTION CURVES	56
QED ATTENUATOR	39
COMPATIBLE MONITORS	
MAESTRO	20
S-LINK	28
M-LINK	32
LIST OF ALL ACCESSORIES	184

## APPLICATION NOTE

LONG PULSE JOULEMETER  
IN BURST MODE

202153

## QE12

## SPECIFICATIONS

	QE12LP-S-MB		QE12LP-H-MB		QE12SP-S-MT		QE12SP-H-MT	
<b>MAX MEASURABLE ENERGY (WITH ATTENUATOR)</b>	3.9 J		3.9 J		1.6 J		1.6 J	
<b>MAX REPETITION FREQUENCY</b>	300 Hz		300 Hz		6000 Hz		6000 Hz	
<b>EFFECTIVE APERTURE</b>	12 x 12 mm		12 x 12 mm		12 x 12 mm		12 x 12 mm	
<b>MEASUREMENT CAPABILITY</b>								
Spectral Range *	Alone	Attenuator	Alone	Attenuator	Alone	Attenuator	Alone	Attenuator
	0.19 – 20 µm	0.3 - 2.1 µm	0.19 – 20 µm	0.3 - 2.1 µm	0.19 – 20 µm <sup>a</sup>	0.3 - 2.1 µm	0.19 – 20 µm <sup>a</sup>	0.3 - 2.1 µm
Maximum Measurable Energy <sup>b</sup>	Alone	Attenuator	Alone	Attenuator	Alone	Attenuator	Alone	Attenuator
1064 nm, 7 ns, 10 Hz <sup>c</sup>	0.85 J	3.9 J	0.85 J	3.9 J	0.70 J	1.60 J	0.70 J	1.60 J
266 nm, 7 ns, 10 Hz	0.70 J	0.81 J	0.70 J	0.81 J	0.10 J	0.25 J	0.10 J	0.25 J
Noise Equivalent Energy <sup>d</sup>	0.7 µJ		0.7 µJ		0.8 µJ		0.8 µJ	
Sensitivity <sup>e, f</sup>	60 V/J		60 V/J		100 V/J		100 V/J	
Max Repetition Frequency	300 Hz		300 Hz		6000 Hz <sup>g</sup>		6000 Hz <sup>g</sup>	
Maximum Pulse Width (typical)	400 µs <sup>**</sup>		400 µs <sup>**</sup>		10 µs		10 µs	
Rise Time (typical 0-100 %)	550 µs		550 µs		20 µs		20 µs	
Calibration Uncertainty <sup>h</sup>	±3 %		±3 %		±3 %		±3 %	
Repeatability	<0.5 %		<0.5 %		<0.5 %		<0.5 %	
<b>DAMAGE THRESHOLDS</b>								
Maximum Average Power	Alone	Attenuator	Alone	Attenuator	Alone	Attenuator	Alone	Attenuator
All Wavelengths	3 W	7.5 W	5 W	12.5 W	3 W	7.5 W	5 W	12.5 W
Maximum Energy Density	Alone	Attenuator	Alone	Attenuator	Alone	Attenuator	Alone	Attenuator
1064 nm, 7 ns, single shot	0.6 J/cm <sup>2</sup>	16 J/cm <sup>2</sup>	0.6 J/cm <sup>2</sup>	16 J/cm <sup>2</sup>	0.50 J/cm <sup>2</sup>	4 J/cm <sup>2</sup>	0.50 J/cm <sup>2</sup>	4 J/cm <sup>2</sup>
1064 nm, 7 ns, 10 Hz	0.6 J/cm <sup>2</sup>	8 J/cm <sup>2</sup>	0.6 J/cm <sup>2</sup>	8 J/cm <sup>2</sup>	0.50 J/cm <sup>2</sup>	2 J/cm <sup>2</sup>	0.50 J/cm <sup>2</sup>	2 J/cm <sup>2</sup>
532 nm, 7 ns, 10 Hz	0.6 J/cm <sup>2</sup>	6 J/cm <sup>2</sup>	0.6 J/cm <sup>2</sup>	6 J/cm <sup>2</sup>	0.07 J/cm <sup>2</sup>	0.35 J/cm <sup>2</sup>	0.07 J/cm <sup>2</sup>	0.35 J/cm <sup>2</sup>
266 nm, 7 ns, 10 Hz	0.5 J/cm <sup>2</sup>	1 J/cm <sup>2</sup>	0.5 J/cm <sup>2</sup>	1 J/cm <sup>2</sup>	0.07 J/cm <sup>2</sup>	0.30 J/cm <sup>2</sup>	0.07 J/cm <sup>2</sup>	0.30 J/cm <sup>2</sup>
Maximum Average Power Density	10 W/cm <sup>2</sup>	600 W/cm <sup>2</sup>	10 W/cm <sup>2</sup> <sup>i</sup>	600 W/cm <sup>2</sup>	10 W/cm <sup>2</sup>	600 W/cm <sup>2</sup>	10 W/cm <sup>2</sup> <sup>i</sup>	600 W/cm <sup>2</sup>
<b>PHYSICAL CHARACTERISTICS</b>								
Effective Aperture (with Attenuator)	12 X 12 mm (9 X 9 mm)							
Absorber	Multi-Band		Multi-Band		Metallic		Metallic	
Dimensions	36H x 36W x 14D mm		36H x 36W x 33D mm		36H x 36W x 14D mm		36H x 36W x 33D mm	
Weight	87 g		117 g		87 g		117 g	
<b>ORDERING INFORMATION</b>								
	Standard	With Attenuator <sup>i</sup>	Standard	With Attenuator <sup>i</sup>	Standard	With Attenuator <sup>i</sup>	Standard	With Attenuator <sup>i</sup>
Product Name	QE12LP-S-MB	QE12LP-S-MB-QED	QE12LP-H-MB	QE12LP-H-MB-QED	QE12SP-S-MT	Call	QE12SP-H-MT	Call
Product Number (Including stand)	200508	202180	200510	202181	200511		200512	
 Add Extension for INTEGRA	-INT	-INT	-INT	-INT	-INT	Call	-INT	Call
Product Number (Including stand)	202723	202725	202181	202721	202729		202727	

Specifications are subject to change without notice

\* \* Also available on special order: The Extra Long Pulse Series QE12ELP-MB for pulse widths up to 2 msec, custom-tuned for rep. rate, sensitivity, and pulse width.

\* For the calibrated spectral range, see the user manual.

a. Detectors with the MT coating can be used within the range 0.19 to 20 µm, however the absorption in the IR wavelengths decreases significantly. This, in turn, reduces the sensitivity and increases the noise level.

b. Not exceeding Maximum Average Power.

c. Increasing pulse width increases the maximum measurable energy.

d. Nominal value, actual value depends on electrical noise in the measurement system.

e. Load: 1 MΩ and ≤ 30 pF.

f. Maximum output voltage = sensitivity x maximum energy.

g. 5700 Hz with Integra version.

h. Excludes non-linearities.

i. At 3 W. Maximum Average Power Density is 10 W/cm<sup>2</sup> @ 5 W for -H versions.

j. When -QED extension is added, the QE + QED come as one unit with a combined calibration only. See the "QED Attenuator" page for more options on the calibration.



# QE25

25 x 25 mm, 2  $\mu$ J - 23 J

MONITORS

ENERGY DETECTORS

POWER DETECTORS

HIGH POWER SOLUTIONS

PHOTO DETECTORS

THZ DETECTORS

OEM DETECTORS

SPECIAL PRODUCTS

BEAM DIAGNOSTICS



## KEY FEATURES

- 1. MODULAR CONCEPT**  
Increase the power capability of your detector:  
2 different cooling modules
- 2. LOW NOISE LEVEL**  
2  $\mu$ J for the MT coating
- 3. QED ATTENUATOR AVAILABLE**
  - Measure up to 5X higher energies
  - Available with optional calibration, all wavelengths between 532 & 1064 nm, or single wavelength
- 4. AVAILABLE WITH METALLIC ABSORBER**  
High Repetition Rate (6000 Hz)
- 5. TEST TARGET INCLUDED**  
With the MB models
- 6. SMART INTERFACE**  
Containing all the calibration data

## AVAILABLE MODELS

QE25LP-S-MB  
(Broadband-Convection)QE25LP-H-MB  
(Broadband-Heatsink)QE25SP-S-MT  
(Metallic-Convection)QE25SP-H-MT  
(Metallic-Heatsink)

## ACCESSORIES

Stand with Delrin Post  
(Model Number: 200428)DB-15 to BNC Adaptor  
(Model Number: 200036)QE25 Attenuator  
(Model Number: 201199)

Pelican Carrying Case

## SEE ALSO

HOW IT WORKS	12
CALIBRATION	6
TECHNICAL DRAWINGS	54
ABSORPTION CURVES	56
QED ATTENUATOR	39
COMPATIBLE MONITORS	
MAESTRO	20
S-LINK	28
M-LINK	32
LIST OF ALL ACCESSORIES	184
APPLICATION NOTES	
LONG PULSE JOULEMETER IN BURST MODE	202153
QEAS: UV ATTENUATOR	202185

## QE25

## SPECIFICATIONS

	QE25LP-S-MB	QE25LP-H-MB	QE25SP-S-MT	QE25SP-H-MT
<b>MAX MEASURABLE ENERGY (WITH ATTENUATOR)</b>	23 J	23 J	10 J	10 J
<b>MAX REPETITION FREQUENCY</b>	300 Hz	300 Hz	6000 Hz	6000 Hz
<b>EFFECTIVE APERTURE</b>	25 x 25 mm	25 x 25 mm	25 x 25 mm	25 x 25 mm

MEASUREMENT CAPABILITY								
Spectral Range *	QE25LP-S-MB		QE25LP-H-MB		QE25SP-S-MT		QE25SP-H-MT	
	Alone	Attenuator	Alone	Attenuator	Alone	Attenuator	Alone	Attenuator
Maximum Measurable Energy <sup>c</sup>	Alone	Attenuator	Alone	Attenuator	Alone	Attenuator	Alone	Attenuator
1064 nm, 7 ns, 10 Hz <sup>d</sup>	3.8 J	23 J	3.8 J	23 J	3.0 J	10 J	3.0 J	10 J
266 nm, 7 ns, 10 Hz	3.1 J	4.8 J	3.1 J	4.8 J	0.44 J	1.45 J	0.44 J	1.45 J
Noise Equivalent Energy <sup>e</sup>	4 µJ		4 µJ		2 µJ		2 µJ	
Sensitivity <sup>f,g</sup>	10 V/J		10 V/J		20 V/J		20 V/J	
Max Repetition Frequency	300 Hz (1000 Hz in option)		300 Hz (1000 Hz in option)		6000 Hz <sup>h</sup>		6000 Hz <sup>h</sup>	
Maximum Pulse Width (typical)	400 µs <sup>**</sup>		400 µs <sup>**</sup>		10 µs		10 µs	
Rise Time (typical 0-100 %)	550 µs		550 µs		20 µs		20 µs	
Calibration Uncertainty <sup>i</sup>	±3 %		±3 %		±3 %		±3 %	
Repeatability	<0.5 %		<0.5 %		<0.5 %		<0.5 %	

DAMAGE THRESHOLDS								
Maximum Average Power	QE25LP-S-MB		QE25LP-H-MB		QE25SP-S-MT		QE25SP-H-MT	
	Alone	Attenuator	Alone	Attenuator	Alone	Attenuator	Alone	Attenuator
All Wavelengths	5 W	15 W	10 W	30 W	5 W	15 W	10 W	30 W
Maximum Energy Density	QE25LP-S-MB		QE25LP-H-MB		QE25SP-S-MT		QE25SP-H-MT	
	Alone	Attenuator	Alone	Attenuator	Alone	Attenuator	Alone	Attenuator
1064 nm, 7 ns, single shot	0.6 J/cm <sup>2</sup>	16 J/cm <sup>2</sup>	0.6 J/cm <sup>2</sup>	16 J/cm <sup>2</sup>	0.50 J/cm <sup>2</sup>	4 J/cm <sup>2</sup>	0.50 J/cm <sup>2</sup>	4 J/cm <sup>2</sup>
1064 nm, 7 ns, 10 Hz	0.6 J/cm <sup>2</sup>	8 J/cm <sup>2</sup>	0.6 J/cm <sup>2</sup>	8 J/cm <sup>2</sup>	0.50 J/cm <sup>2</sup>	2 J/cm <sup>2</sup>	0.50 J/cm <sup>2</sup>	2 J/cm <sup>2</sup>
532 nm, 7 ns, 10 Hz	0.6 J/cm <sup>2</sup>	6 J/cm <sup>2</sup>	0.6 J/cm <sup>2</sup>	6 J/cm <sup>2</sup>	0.07 J/cm <sup>2</sup>	0.35 J/cm <sup>2</sup>	0.07 J/cm <sup>2</sup>	0.35 J/cm <sup>2</sup>
266 nm, 7 ns, 10 Hz	0.5 J/cm <sup>2</sup>	1 J/cm <sup>2</sup>	0.5 J/cm <sup>2</sup>	1 J/cm <sup>2</sup>	0.07 J/cm <sup>2</sup>	0.30 J/cm <sup>2</sup>	0.07 J/cm <sup>2</sup>	0.30 J/cm <sup>2</sup>
Maximum Average Power Density	10 W/cm <sup>2</sup>	600 W/cm <sup>2</sup>	10 W/cm <sup>2</sup> <sup>j</sup>	600 W/cm <sup>2</sup>	10 W/cm <sup>2</sup>	600 W/cm <sup>2</sup>	10 W/cm <sup>2</sup> <sup>j</sup>	600 W/cm <sup>2</sup>

PHYSICAL CHARACTERISTICS								
Effective Aperture (with Attenuator)	25 X 25 mm (22 X 22 mm)							
Absorber	Multi-Band		Multi-Band		Metallic		Metallic	
Dimensions	50H x 50W x 14D mm		50H x 50W x 52.5D mm		50H x 50W x 14D mm		50H x 50W x 52.5D mm	
Weight	120 g		187 g		120 g		187 g	

ORDERING INFORMATION	QE25LP-S-MB		QE25LP-H-MB		QE25SP-S-MT		QE25SP-H-MT	
	Standard	With Attenuator <sup>k</sup>	Standard	With Attenuator <sup>k</sup>	Standard	With Attenuator <sup>k</sup>	Standard	With Attenuator <sup>k</sup>
Product Name	QE25LP-S-MB	QE25LP-S-MB-QED	QE25LP-H-MB	QE25LP-H-MB-QED	QE25SP-S-MT	Call	QE25SP-H-MT	Call
Product Number (Including stand)	200312	202184	200313	202185	200310		200311	
 Add Extension for INTEGRA	-INT	-INT	-INT	-INT	-INT	Call	-INT	Call
Product Number (Including stand)	202380	202739	202382	202733	202384		202386	

Specifications are subject to change without notice

\* \* Also available on special order: The Extra Long Pulse Series QE25ELP-MB for pulse widths up to 4 msec, custom-tuned for rep. rate, sensitivity, and pulse width.

\* For the calibrated spectral range, see the user manual.

- a. 0.19 - 0.3 µm with QEAS Attenuator, 0.3 - 2.1 µm with QED Attenuator.  
 b. Detectors with the MT coating can be used within the range 0.19 to 20 µm, however the absorption in the IR wavelengths decreases significantly. This, in turn, reduces the sensitivity and increases the noise level. Nevertheless, each detector is individually scanned and the wavelength correction factor (PWC) is NIST traceable in the range of 248 nm to 2.5 µm.  
 c. Not exceeding Maximum Average Power.

d. Increasing pulse width increases the maximum measurable energy.

e. Nominal value, actual value depends on electrical noise in the measurement system.

f. Load: 1 MΩ and ≤ 30 pF.

g. Maximum output voltage = sensitivity x maximum energy.

h. 5700 Hz with Integra version.

i. Excludes non-linearities.

j. At 5 W. Maximum Average Power Density is 10 W/cm<sup>2</sup> @ 10 W for -H versions.

k. When -QED extension is added, the QE + QED come as one unit with a combined calibration only. See the "QED Attenuator" page for more options on the calibration.



# QE50

50 x 50 mm, 10  $\mu$ J - 85 J

## KEY FEATURES

- 1. MODULAR CONCEPT**  
Increase the power capability of your detector:  
2 different cooling modules
- 2. LOW NOISE LEVEL**  
10  $\mu$ J for both coatings
- 3. QED ATTENUATOR AVAILABLE**
  - Measure up to 5X higher energies
  - Available with optional calibration, all wavelengths between 532 & 1064 nm, or single wavelength
- 4. AVAILABLE WITH METALLIC ABSORBER**  
High Repetition Rate (4000 Hz)
- 5. TEST TARGET INCLUDED**  
With the MB models
- 6. SMART INTERFACE**  
Containing all the calibration data

## AVAILABLE MODELS

QE50LP-S-MB  
(Broadband-Convection)QE50LP-H-MB  
(Broadband-Heatsink)QE50SP-S-MT  
(Metallic-Convection)QE50SP-H-MT  
(Metallic-Heatsink)

## ACCESSORIES

Stand with Delrin Post  
(Model Number: 200428)DB-15 to BNC Adaptor  
(Model Number: 200036)QE50 Attenuator  
(Model Number: 201198)

Pelican Carrying Case

## SEE ALSO

HOW IT WORKS	12
CALIBRATION	6
TECHNICAL DRAWINGS	54
ABSORPTION CURVES	56
QED ATTENUATOR	39
COMPATIBLE MONITORS	
MAESTRO	20
S-LINK	28
M-LINK	32
LIST OF ALL ACCESSORIES	184
APPLICATION NOTES	
LONG PULSE JOULEMETER IN BURST MODE	202153
QEAS: UV ATTENUATOR	202185

## QE50



\*Also traceable to NRC-CNRC

## SPECIFICATIONS

	QE50LP-S-MB		QE50LP-H-MB		QE50SP-S-MT		QE50SP-H-MT	
<b>MAX MEASURABLE ENERGY (WITH ATTENUATOR)</b>	85 J		85 J		44 J		44 J	
<b>MAX REPETITION FREQUENCY</b>	200 Hz		200 Hz		4000 Hz		4000 Hz	
<b>EFFECTIVE APERTURE</b>	50 x 50 mm		50 x 50 mm		50 x 50 mm		50 x 50 mm	
<b>MEASUREMENT CAPABILITY</b>								
Spectral Range *	Alone	Attenuator	Alone	Attenuator	Alone	Attenuator	Alone	Attenuator
	0.19 – 20 µm	0.19 - 2.1 µm <sup>a</sup>	0.19 – 20 µm	0.19 - 2.1 µm <sup>a</sup>	0.19 – 20 µm <sup>b</sup>	0.19 - 2.1 µm <sup>a</sup>	0.19 – 20 µm <sup>b</sup>	0.19 - 2.1 µm <sup>a</sup>
Maximum Measurable Energy <sup>c</sup>	Alone	Attenuator	Alone	Attenuator	Alone	Attenuator	Alone	Attenuator
1064 nm, 7 ns, 10 Hz <sup>d</sup>	15 J	85 J	15 J	85 J	13 J	44 J	13 J	44 J
266 nm, 7 ns, 10 Hz	12.5 J	22 J	12.5 J	22 J	1.8 J	6.5 J	1.8 J	6.5 J
Noise Equivalent Energy <sup>e</sup>	10 µJ		10 µJ		10 µJ		10 µJ	
Sensitivity <sup>f,g</sup>	3 V/J		3 V/J		4 V/J		4 V/J	
Max Repetition Frequency	200 Hz		200 Hz		4000 Hz		4000 Hz	
Maximum Pulse Width (typical)	675 µs <sup>**</sup>		675 µs <sup>**</sup>		10 µs		10 µs	
Rise Time (typical 0-100 %)	900 µs		900 µs		20 µs		20 µs	
Calibration Uncertainty <sup>h</sup>	±3 %		±3 %		±3 %		±3 %	
Repeatability	<0.5 %		<0.5 %		<0.5 %		<0.5 %	
<b>DAMAGE THRESHOLDS</b>								
Maximum Average Power	Alone	Attenuator	Alone	Attenuator	Alone	Attenuator	Alone	Attenuator
All Wavelengths	10 W	25 W	20 W	45 W	10 W	25 W	20 W	45 W
Maximum Energy Density	Alone	Attenuator	Alone	Attenuator	Alone	Attenuator	Alone	Attenuator
1064 nm, 7 ns, single shot	0.6 J/cm <sup>2</sup>	16 J/cm <sup>2</sup>	0.6 J/cm <sup>2</sup>	16 J/cm <sup>2</sup>	0.50 J/cm <sup>2</sup>	4 J/cm <sup>2</sup>	0.50 J/cm <sup>2</sup>	4 J/cm <sup>2</sup>
1064 nm, 7 ns, 10 Hz	0.6 J/cm <sup>2</sup>	8 J/cm <sup>2</sup>	0.6 J/cm <sup>2</sup>	8 J/cm <sup>2</sup>	0.50 J/cm <sup>2</sup>	2 J/cm <sup>2</sup>	0.50 J/cm <sup>2</sup>	2 J/cm <sup>2</sup>
532 nm, 7 ns, 10 Hz	0.6 J/cm <sup>2</sup>	6 J/cm <sup>2</sup>	0.6 J/cm <sup>2</sup>	6 J/cm <sup>2</sup>	0.07 J/cm <sup>2</sup>	0.35 J/cm <sup>2</sup>	0.07 J/cm <sup>2</sup>	0.35 J/cm <sup>2</sup>
266 nm, 7 ns, 10 Hz	0.5 J/cm <sup>2</sup>	1 J/cm <sup>2</sup>	0.5 J/cm <sup>2</sup>	1 J/cm <sup>2</sup>	0.07 J/cm <sup>2</sup>	0.30 J/cm <sup>2</sup>	0.07 J/cm <sup>2</sup>	0.30 J/cm <sup>2</sup>
Maximum Average Power Density	10 W/cm <sup>2</sup>	600 W/cm <sup>2</sup>	10 W/cm <sup>2</sup> <sup>i</sup>	600 W/cm <sup>2</sup>	10 W/cm <sup>2</sup>	600 W/cm <sup>2</sup>	10 W/cm <sup>2</sup> <sup>i</sup>	600 W/cm <sup>2</sup>
<b>PHYSICAL CHARACTERISTICS</b>								
Effective Aperture (with Attenuator)	50 X 50 mm (47 X 47 mm)							
Absorber	Multi-Band		Multi-Band		Metallic		Metallic	
Dimensions	75H x 75W x 15D mm		75H x 75W x 44D mm		75H x 75W x 15D mm		75H x 75W x 44D mm	
Weight	209 g		338 g		209 g		338 g	
<b>ORDERING INFORMATION</b>								
	Standard	With Attenuator <sup>j</sup>	Standard	With Attenuator <sup>j</sup>	Standard	With Attenuator <sup>j</sup>	Standard	With Attenuator <sup>j</sup>
Product Name	QE50LP-S-MB	QE50LP-S-MB-QED	QE50LP-H-MB	QE50LP-H-MB-QED	QE50SP-S-MT	Call	QE50SP-H-MT	Call
Product Number (Including stand)	200307	202188	200308	202189	200305		200306	
Add Extension for INTEGRA	-INT	-INT	-INT	-INT	-INT	Call	-INT	Call
Product Number (Including stand)	202749	202751	202745	202747	202755		202753	

Specifications are subject to change without notice

\* \* Also available on special order: The Extra Long Pulse Series QE50ELP-MB for pulse widths up to 5 msec, custom-tuned for rep. rate, sensitivity, and pulse width.

\* For the calibrated spectral range, see the user manual.

a. 0.19 - 0.3 µm with QEAS Attenuator, 0.3 - 2.1 µm with QED Attenuator.

b. Detectors with the MT coating can be used within the range 0.19 to 20 µm, however the absorption in the IR wavelengths decreases significantly. This, in turn, reduces the sensitivity and increases the noise level. Nevertheless, each detector is individually scanned and the wavelength correction factor (PWC) is NIST traceable in the range of 248 nm to 2.5 µm.

c. Not exceeding Maximum Average Power.

d. Increasing pulse width increases the maximum measurable energy.

e. Nominal value, actual value depends on electrical noise in the measurement system.

f. Load: 1 MΩ and ≤ 30 pF.

g. Maximum output voltage = sensitivity x maximum energy.

h. Excludes non-linearities.

i. At 10 W. Maximum Average Power Density is 5 W/cm<sup>2</sup> @ 20 W for -H versions.

j. When -QED extension is added, the QE + QED come as one unit with a combined calibration only. See the "QED Attenuator" page for more options on the calibration.



# QE65

65 x 65 mm, 10  $\mu$ J - 200 J

## KEY FEATURES

- 1. MODULAR CONCEPT**  
Increase the power capability of your detector:  
2 different cooling modules
- 2. LARGE APERTURE**  
Effective aperture of 65 x 65 mm
- 3. QED ATTENUATOR AVAILABLE**
  - Measure up to 5X higher energies
  - Available with optional calibration, all wavelengths between 532 & 1064 nm, or single wavelength
- 4. LOW NOISE LEVEL**  
10  $\mu$ J for the MB coating
- 5. TEST TARGET INCLUDED**  
With the MB models
- 6. SMART INTERFACE**  
Containing all the calibration data

## AVAILABLE MODELS



QE65LP-S-MB  
(Broadband-Convection)



QE65LP-H-MB  
(Broadband-Heatsink)



QE65ELP-S-MB  
(XLong Pulse-Convection)



QE65ELP-S-MB  
(XLong Pulse-Heatsink)

## ACCESSORIES



Stand with Delrin Post  
(200428, For -S Model)



Stand with Delrin Post  
(201284, For -H Model)



DB-15 to BNC Adaptor  
(Model Number: 200036)



QED-65 Attenuator  
(Model Number: 201282)



Pelican Carrying Case

## SEE ALSO

HOW IT WORKS	12
CALIBRATION	6
TECHNICAL DRAWINGS	54
ABSORPTION CURVES	56
QED ATTENUATOR	39
COMPATIBLE MONITORS	
MAESTRO	20
S-LINK	28
M-LINK	32
LIST OF ALL ACCESSORIES	184
APPLICATION NOTE	
LONG PULSE JOULEMETER IN BURST MODE	202153

## QE65



\*Also traceable to NRC-CNRC

## SPECIFICATIONS

	QE65LP-S-MB		QE65LP-H-MB		QE65ELP-S-MB		QE65ELP-H-MB	
<b>MAX MEASURABLE ENERGY (WITH ATTENUATOR)</b>	200 J		200 J		200 J		200 J	
<b>MAX REPETITION FREQUENCY</b>	100 Hz		100 Hz		20 Hz		20 Hz	
<b>EFFECTIVE APERTURE</b>	65 x 65 mm		65 x 65 mm		65 x 65 mm		65 x 65 mm	
<b>MEASUREMENT CAPABILITY</b>								
Spectral Range *	Alone	Attenuator	Alone	Attenuator	Alone	Attenuator	Alone	Attenuator
	0.19 – 20 $\mu\text{m}$	0.3 - 2.1 $\mu\text{m}$	0.19 – 20 $\mu\text{m}$	0.3 - 2.1 $\mu\text{m}$	0.19 – 20 $\mu\text{m}$	0.3 - 2.1 $\mu\text{m}$	0.19 – 20 $\mu\text{m}$	0.3 - 2.1 $\mu\text{m}$
Maximum Measurable Energy <sup>a, b</sup>	Alone	Attenuator	Alone	Attenuator	Alone	Attenuator	Alone	Attenuator
1064 nm, 150 $\mu\text{s}$ pulse, Single shot <sup>c</sup>	50 J	200 J	50 J	200 J	50 J	200 J	50 J	200 J
1064 nm, 7 ns, 10 Hz	25 J	125 J	25 J	125 J	25 J	125 J	25 J	125 J
266 nm, 7 ns, 10 Hz	20 J	35 J	20 J	35 J	20 J	35 J	20 J	35 J
Noise Equivalent Energy <sup>d</sup>	10 $\mu\text{J}$		10 $\mu\text{J}$		20 $\mu\text{J}$		20 $\mu\text{J}$	
Sensitivity <sup>e, f</sup>	4 V/J		4 V/J		1.5 V/J		1.5 V/J	
Max Repetition Frequency	100 Hz		100 Hz		20 Hz		20 Hz	
Maximum Pulse Width (typical)	0.7 ms		0.7 ms		5 ms		5 ms	
Rise Time (typical 0-100 %)	1 ms		1 ms		6 ms		6 ms	
Calibration Uncertainty <sup>g</sup>	$\pm 3\%$		$\pm 3\%$		$\pm 3\%$		$\pm 3\%$	
Repeatability	<0.5 %		<0.5 %		<0.5 %		<0.5 %	
<b>DAMAGE THRESHOLDS</b>								
Maximum Average Power	Alone	Attenuator	Alone	Attenuator	Alone	Attenuator	Alone	Attenuator
All Wavelengths	12 W	30 W	40 W	90 W	12 W	30 W	40 W	90 W
Maximum Energy Density	Alone	Attenuator	Alone	Attenuator	Alone	Attenuator	Alone	Attenuator
1064 nm, 150 $\mu\text{s}$ , 10 Hz	1.2 J/cm <sup>2</sup>	14 J/cm <sup>2</sup>	1.2 J/cm <sup>2</sup>	14 J/cm <sup>2</sup>	1.2 J/cm <sup>2</sup>	14 J/cm <sup>2</sup>	1.2 J/cm <sup>2</sup>	14 J/cm <sup>2</sup>
1064 nm, 7 ns, single shot	0.6 J/cm <sup>2</sup>	16 J/cm <sup>2</sup>	0.6 J/cm <sup>2</sup>	16 J/cm <sup>2</sup>	0.6 J/cm <sup>2</sup>	16 J/cm <sup>2</sup>	0.6 J/cm <sup>2</sup>	16 J/cm <sup>2</sup>
1064 nm, 7 ns, 10 Hz	0.6 J/cm <sup>2</sup>	8 J/cm <sup>2</sup>	0.6 J/cm <sup>2</sup>	8 J/cm <sup>2</sup>	0.6 J/cm <sup>2</sup>	8 J/cm <sup>2</sup>	0.6 J/cm <sup>2</sup>	8 J/cm <sup>2</sup>
532 nm, 7 ns, 10 Hz	0.6 J/cm <sup>2</sup>	6 J/cm <sup>2</sup>	0.6 J/cm <sup>2</sup>	6 J/cm <sup>2</sup>	0.6 J/cm <sup>2</sup>	6 J/cm <sup>2</sup>	0.6 J/cm <sup>2</sup>	6 J/cm <sup>2</sup>
266 nm, 7 ns, 10 Hz	0.5 J/cm <sup>2</sup>	1 J/cm <sup>2</sup>	0.5 J/cm <sup>2</sup>	1 J/cm <sup>2</sup>	0.5 J/cm <sup>2</sup>	1 J/cm <sup>2</sup>	0.5 J/cm <sup>2</sup>	1 J/cm <sup>2</sup>
Maximum Average Power Density (@12 W)	10 W/cm <sup>2</sup>	600 W/cm <sup>2</sup>	10 W/cm <sup>2</sup> <sup>h</sup>	600 W/cm <sup>2</sup>	10 W/cm <sup>2</sup>	600 W/cm <sup>2</sup>	10 W/cm <sup>2</sup> <sup>h</sup>	600 W/cm <sup>2</sup>
<b>PHYSICAL CHARACTERISTICS</b>								
Effective Aperture (with Attenuator)	65 X 65 mm (62 X 62 mm)							
Absorber	Multi-Band		Multi-Band		Multi-Band		Multi-Band	
Dimensions	90H x 90W x 20D mm		90H x 90W x 94D mm		90H x 90W x 20D mm		90H x 90W x 94D mm	
Weight	440 g		900 g		440 g		900 g	
<b>ORDERING INFORMATION</b>								
	Standard	With Attenuator <sup>i</sup>	Standard	With Attenuator <sup>i</sup>	Standard	Standard		
Product Name	QE65LP-S-MB	QE65LP-S-MB-QED	QE65LP-H-MB	QE65LP-H-MB-QED	QE65ELP-S-MB	QE65ELP-H-MB		
Product Number (Including stand)	201255	202192	201256	202193	201324	201325		
Add Extension for INTEGRA	-INT	-INT	-INT	-INT	-INT	-INT		
Product Number (Including stand)	202765		202761		202759	202757		

Specifications are subject to change without notice

\* For the calibrated spectral range, see the user manual.

a. Not exceeding Maximum Average Power.

b. Maximum measurable energy depends on the monitor.

c. Increasing pulse width increases the maximum measurable energy.

d. Nominal value, actual value depends on electrical noise in the measurement system.

e. Load: 1 M $\Omega$  and  $\leq$  30 pF.

f. Maximum output voltage = sensitivity x maximum energy.

g. Excludes non-linearities.

h. At 12 W. Maximum Average Power Density is 5 W/cm<sup>2</sup> @ 40 W.

i. When -QED extension is added, the QE + QED come as one unit with a combined calibration only. See the "QED Attenuator" page for more options on the calibration.



# QE95

95 mm Ø, 15 µJ - 250 J



## KEY FEATURES

- 1. MODULAR CONCEPT**  
Increase the power capability of your detector:  
2 different cooling modules
- 2. EXTRA LARGE APERTURE**  
Effective aperture of 95 mm Ø
- 3. QED ATTENUATOR AVAILABLE**
  - Measure up to 5X higher energies
  - Available with optional calibration, all wavelengths between 532 & 1064 nm, or single wavelength
- 4. LOW NOISE LEVEL**  
15 µJ for the MB coating
- 5. TEST TARGET INCLUDED**  
With the MB models
- 6. SMART INTERFACE**  
Containing all the calibration data

## AVAILABLE MODELS



QE95LP-S-MB  
(Broadband-Convection)



QE95LP-H-MB  
(Broadband-Heatsink)



QE95ELP-S-MB  
(Long Pulse-Convection)



QE95ELP-H-MB  
(Long Pulse-Heatsink)

## ACCESSORIES



Stand with Delrin Post  
(200428, For -S Model)



Stand with Delrin Post  
(201284, For -H Model)



DB-15 to BNC Adaptor  
(Model Number: 200036)



QED-95 Attenuator  
(Model Number: 201323)



Pelican Carrying Case

## SEE ALSO

HOW IT WORKS	<b>12</b>
CALIBRATION	<b>6</b>
TECHNICAL DRAWINGS	<b>54</b>
ABSORPTION CURVES	<b>56</b>
QED ATTENUATOR	<b>39</b>
COMPATIBLE MONITORS	
MAESTRO	<b>20</b>
S-LINK	<b>28</b>
M-LINK	<b>32</b>
LIST OF ALL ACCESSORIES	<b>184</b>

## APPLICATION NOTE

LONG PULSE JOULEMETER  
IN BURST MODE

202153

## QE95



\*Also traceable to NRC-CNRC

## SPECIFICATIONS

	QE95LP-S-MB		QE95LP-H-MB		QE95ELP-S-MB		QE95ELP-H-MB	
<b>MAX MEASURABLE ENERGY (WITH ATTENUATOR)</b>	250 J		250 J		250 J		250 J	
<b>MAX REPETITION FREQUENCY</b>	40 Hz		40 Hz		10 Hz		10 Hz	
<b>EFFECTIVE APERTURE</b>	95 mm Ø		95 mm Ø		95 mm Ø		95 mm Ø	
<b>MEASUREMENT CAPABILITY</b>								
Spectral Range *	Alone	Attenuator	Alone	Attenuator	Alone	Attenuator	Alone	Attenuator
	0.19 – 20 µm	0.3 - 2.1 µm	0.19 – 20 µm	0.3 - 2.1 µm	0.19 – 20 µm	0.3 - 2.1 µm	0.19 – 20 µm	0.3 - 2.1 µm
Maximum Measurable Energy <sup>a,b</sup>	Alone	Attenuator	Alone	Attenuator	Alone	Attenuator	Alone	Attenuator
1064 nm, 150 µs pulse, Single shot <sup>c</sup>	70 J	250 J	70 J	250 J	70 J	250 J	70 J	250 J
1064 nm, 7 ns, 10 Hz	35 J	150 J	35 J	150 J	35 J	150 J	35 J	150 J
266 nm, 7 ns, 10 Hz	30 J	50 J	30 J	50 J	30 J	50 J	30 J	50 J
Noise Equivalent Energy <sup>d</sup>	15 µJ		15 µJ		30 µJ		30 µJ	
Sensitivity <sup>e,f</sup>	2 V/J		2 V/J		0.6 V/J		0.6 V/J	
Max Repetition Frequency	40 Hz		40 Hz		10 Hz		10 Hz	
Maximum Pulse Width (typical)	1.5 ms		1.5 ms		5 ms		5 ms	
Rise Time (typical 0-100 %)	2 ms		2 ms		6 ms		6 ms	
Calibration Uncertainty <sup>g</sup>	±3 %		±3 %		±3 %		±3 %	
Repeatability	<0.5 %		<0.5 %		<0.5 %		<0.5 %	
<b>DAMAGE THRESHOLDS</b>								
Maximum Average Power	Alone	Attenuator	Alone	Attenuator	Alone	Attenuator	Alone	Attenuator
All Wavelengths	20 W	45 W	40 W	90 W	20 W	45 W	40 W	90 W
Maximum Energy Density	Alone	Attenuator	Alone	Attenuator	Alone	Attenuator	Alone	Attenuator
1064 nm, 150 µs, 10 Hz	1.2 J/cm <sup>2</sup>	14 J/cm <sup>2</sup>	1.2 J/cm <sup>2</sup>	14 J/cm <sup>2</sup>	1.2 J/cm <sup>2</sup>	14 J/cm <sup>2</sup>	1.2 J/cm <sup>2</sup>	14 J/cm <sup>2</sup>
1064 nm, 7 ns, single shot	0.6 J/cm <sup>2</sup>	16 J/cm <sup>2</sup>	0.6 J/cm <sup>2</sup>	16 J/cm <sup>2</sup>	0.6 J/cm <sup>2</sup>	16 J/cm <sup>2</sup>	0.6 J/cm <sup>2</sup>	16 J/cm <sup>2</sup>
1064 nm, 7 ns, 10 Hz	0.6 J/cm <sup>2</sup>	8 J/cm <sup>2</sup>	0.6 J/cm <sup>2</sup>	8 J/cm <sup>2</sup>	0.6 J/cm <sup>2</sup>	8 J/cm <sup>2</sup>	0.6 J/cm <sup>2</sup>	8 J/cm <sup>2</sup>
532 nm, 7 ns, 10 Hz	0.6 J/cm <sup>2</sup>	6 J/cm <sup>2</sup>	0.6 J/cm <sup>2</sup>	6 J/cm <sup>2</sup>	0.6 J/cm <sup>2</sup>	6 J/cm <sup>2</sup>	0.6 J/cm <sup>2</sup>	6 J/cm <sup>2</sup>
266 nm, 7 ns, 10 Hz	0.5 J/cm <sup>2</sup>	1 J/cm <sup>2</sup>	0.5 J/cm <sup>2</sup>	1 J/cm <sup>2</sup>	0.5 J/cm <sup>2</sup>	1 J/cm <sup>2</sup>	0.5 J/cm <sup>2</sup>	1 J/cm <sup>2</sup>
Maximum Average Power Density (@12 W)	10 W/cm <sup>2</sup>	600 W/cm <sup>2</sup>	10 W/cm <sup>2</sup> <sup>h</sup>	600 W/cm <sup>2</sup>	10 W/cm <sup>2</sup>	600 W/cm <sup>2</sup>	10 W/cm <sup>2</sup> <sup>h</sup>	600 W/cm <sup>2</sup>
<b>PHYSICAL CHARACTERISTICS</b>								
Effective Aperture (with Attenuator)	95 mm Ø (90 mm Ø)							
Absorber	Multi-Band		Multi-Band		Multi-Band		Multi-Band	
Dimensions	122H x 122W x 20D mm		122H x 122W x 98D mm		122H x 122W x 20D mm		122H x 122W x 98D mm	
Weight	0.78 kg		1.2 kg		0.78 kg		1.2 kg	
<b>ORDERING INFORMATION</b>								
	Standard	With Attenuator <sup>i</sup>	Standard	With Attenuator <sup>i</sup>	Standard	Standard		
Product Name	QE95LP-S-MB	QE95LP-S-MB-QED	QE95LP-H-MB	QE95LP-H-MB-QED	QE95ELP-S-MB	QE95ELP-H-MB		
Product Number (Including stand)	201315	202196	201316	202197	201317	201318		
Add Extension for INTEGRA	-INT	-INT	-INT	-INT	-INT	-INT		
Product Number (Including stand)	202777	202779	202773	202775	202771	202769		

Specifications are subject to change without notice

\* For the calibrated spectral range, see the user manual.

a. Not exceeding Maximum Average Power.

b. maximum depends on monitor.

c. Increasing pulse width increases the maximum measurable energy.

d. Nominal value, actual value depends on electrical noise in the measurement system.

e. Load: 1 MΩ and ≤ 30 pF.

f. Maximum output voltage = sensitivity x maximum energy.

g. Excludes non-linearities.

h. At 12 W. Maximum Average Power Density is 5 W/cm<sup>2</sup> @ 40 W

i. When -QED extension is added, the QE + QED come as one unit with a combined calibration only. See the "QED Attenuator" page for more options on the calibration.

# TECHNICAL DRAWINGS

All dimensions in mm

## QE-B

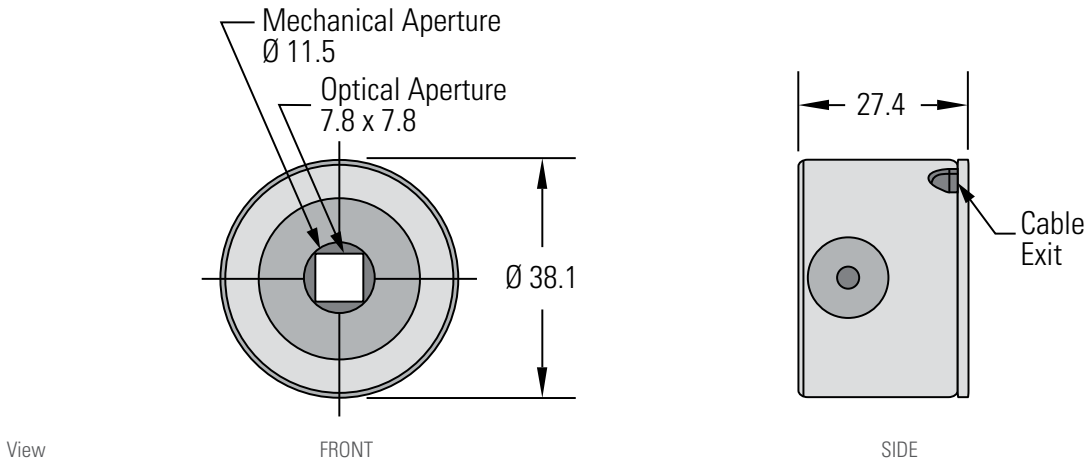

## QE12

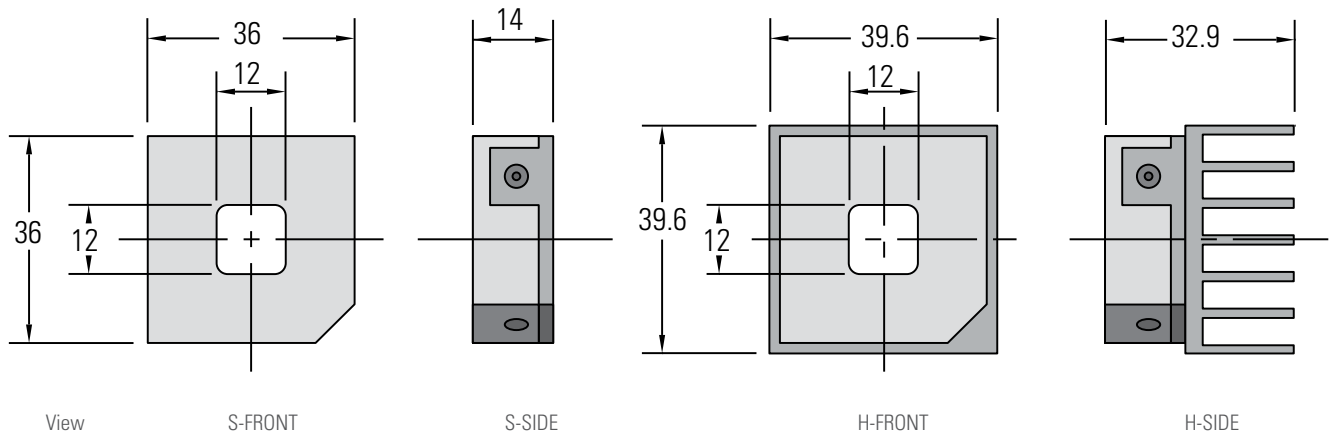

## QE25

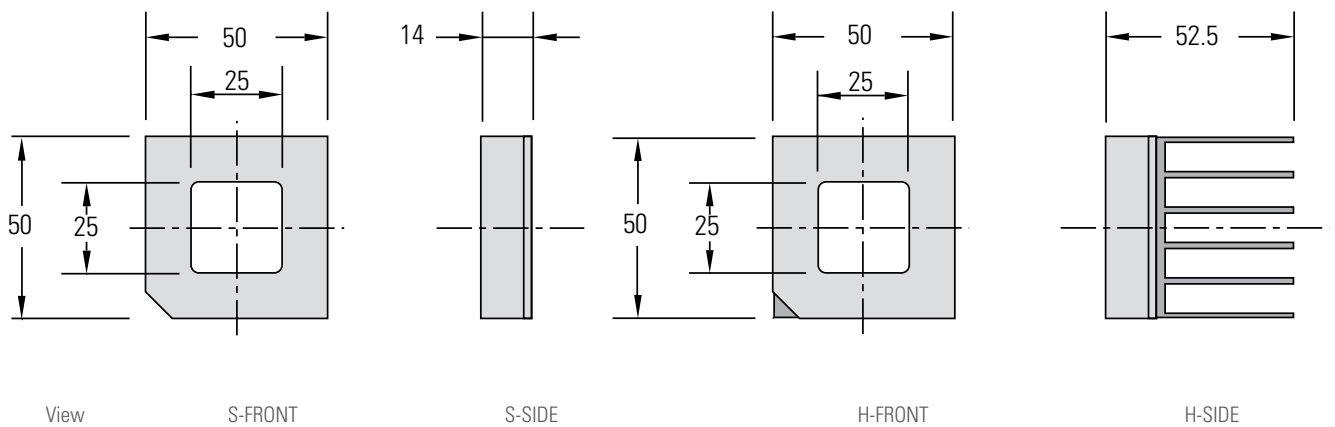

MONITORS  
ENERGY DETECTORS  
POWER DETECTORS  
HIGH-POWER SOLUTIONS  
PHOTO DETECTORS  
THZ DETECTORS  
OEM DETECTORS  
SPECIAL PRODUCTS  
BEAM DIAGNOSTICS

# TECHNICAL DRAWINGS

All dimensions in mm

## QE50

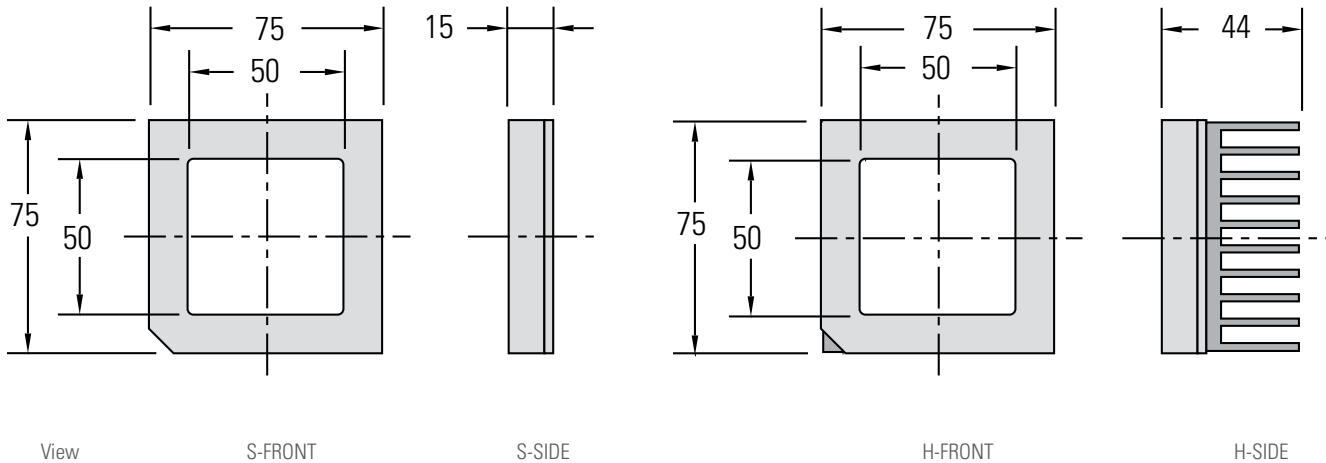

## QE65

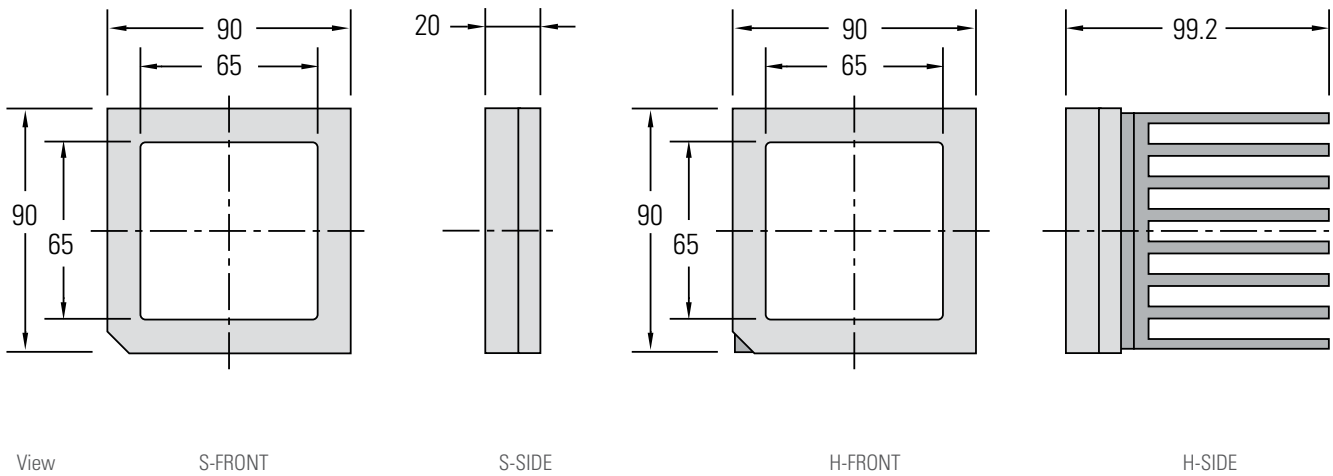

## QE95

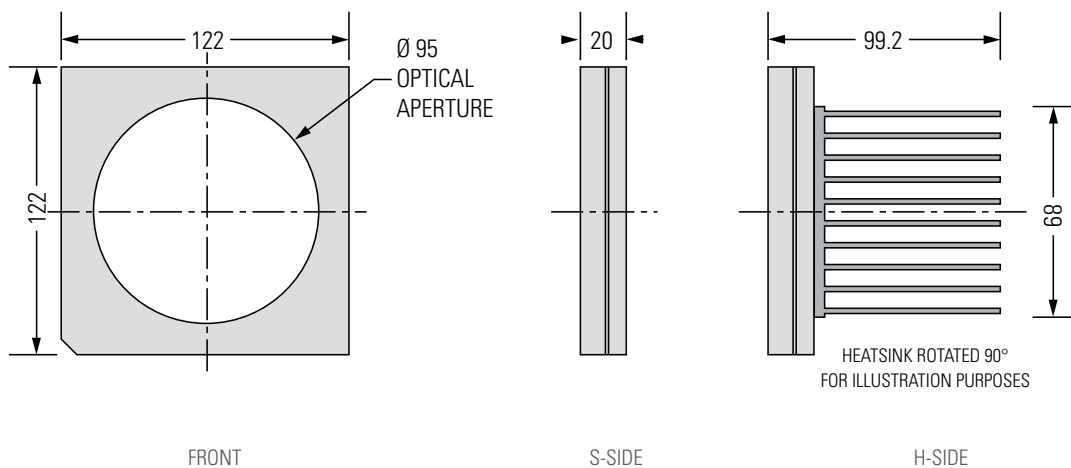

# ABSORPTION CURVES

## QE-B

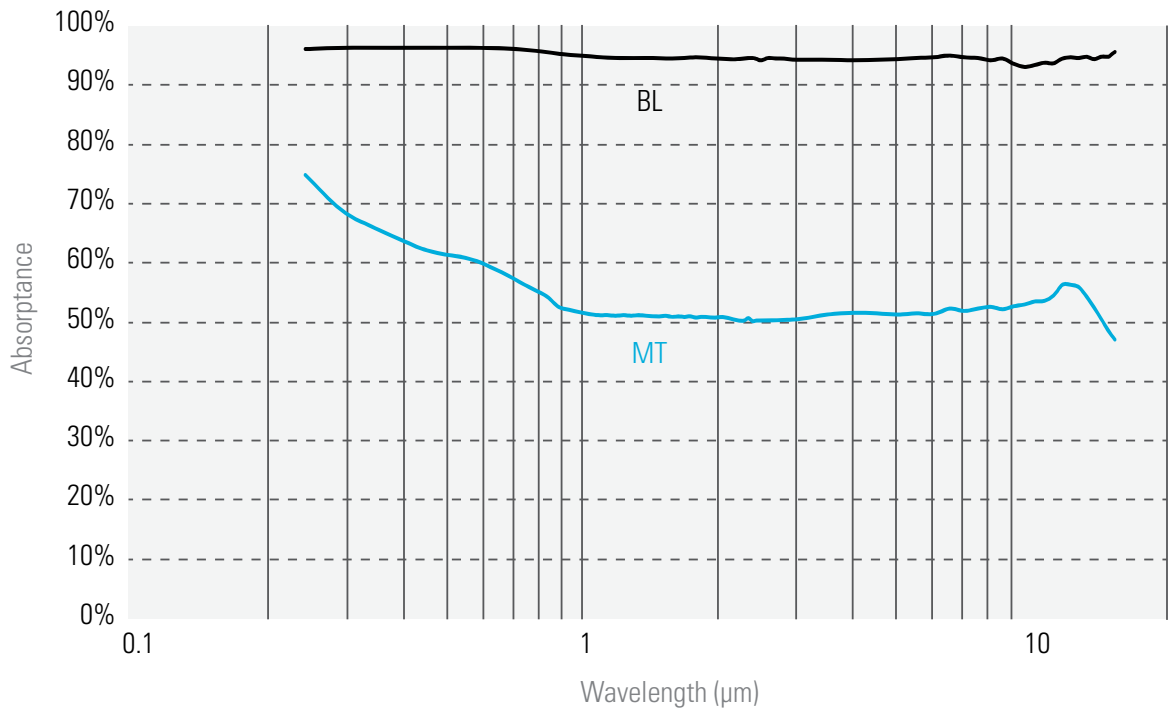

## QE12/25/50/65/95-MB

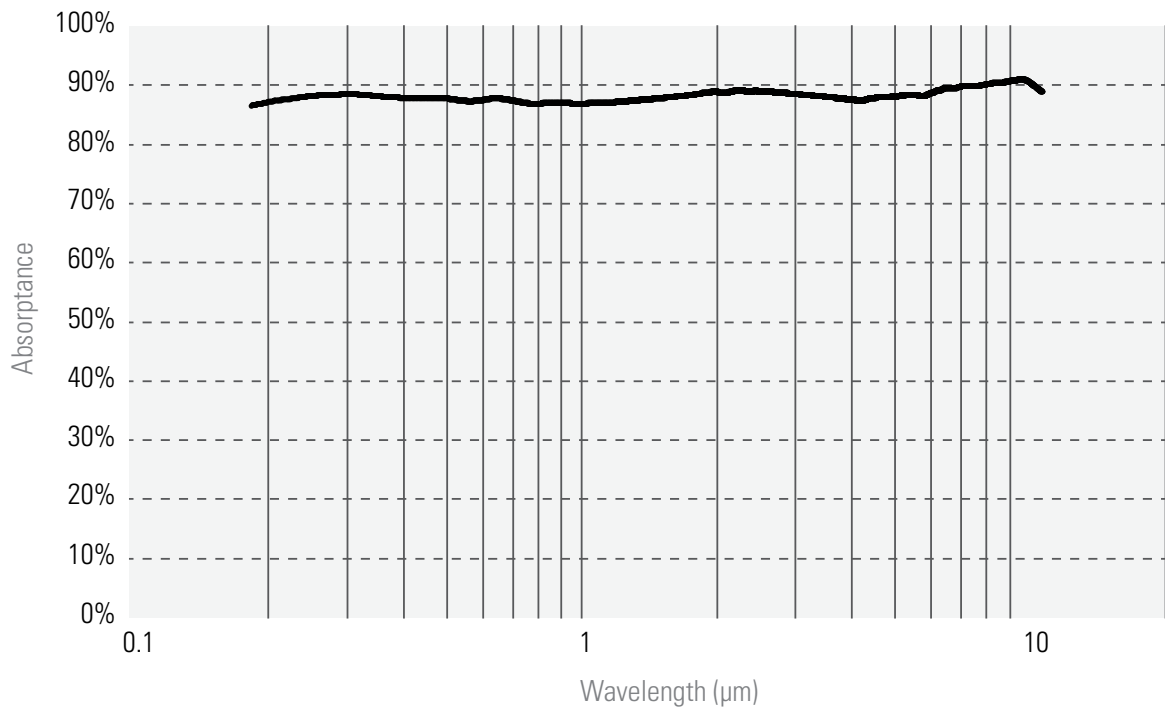

- MONITORS
- ENERGY DETECTORS
- POWER DETECTORS
- HIGH-POWER SOLUTIONS
- PHOTO DETECTORS
- THZ DETECTORS
- OEM DETECTORS
- SPECIAL PRODUCTS
- BEAM DIAGNOSTICS

# ABSORPTION CURVES

QE12/25/50/65/95-MT

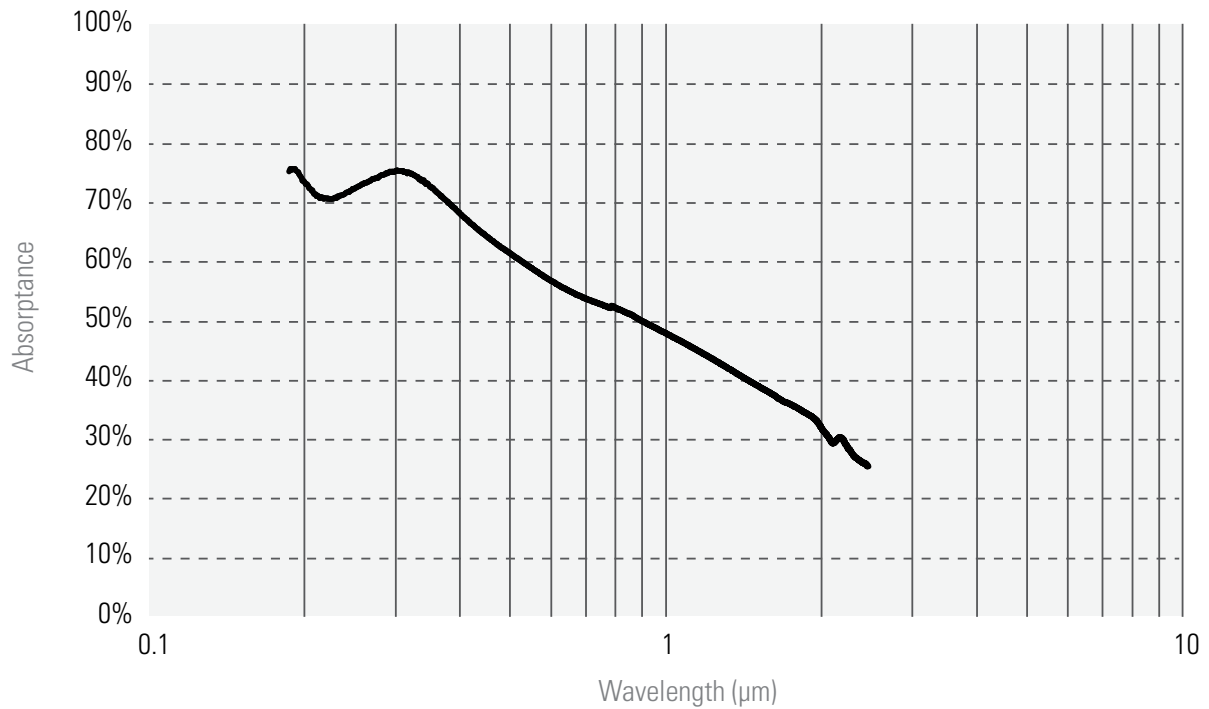

## QED AND QEAS ATTENUATORS

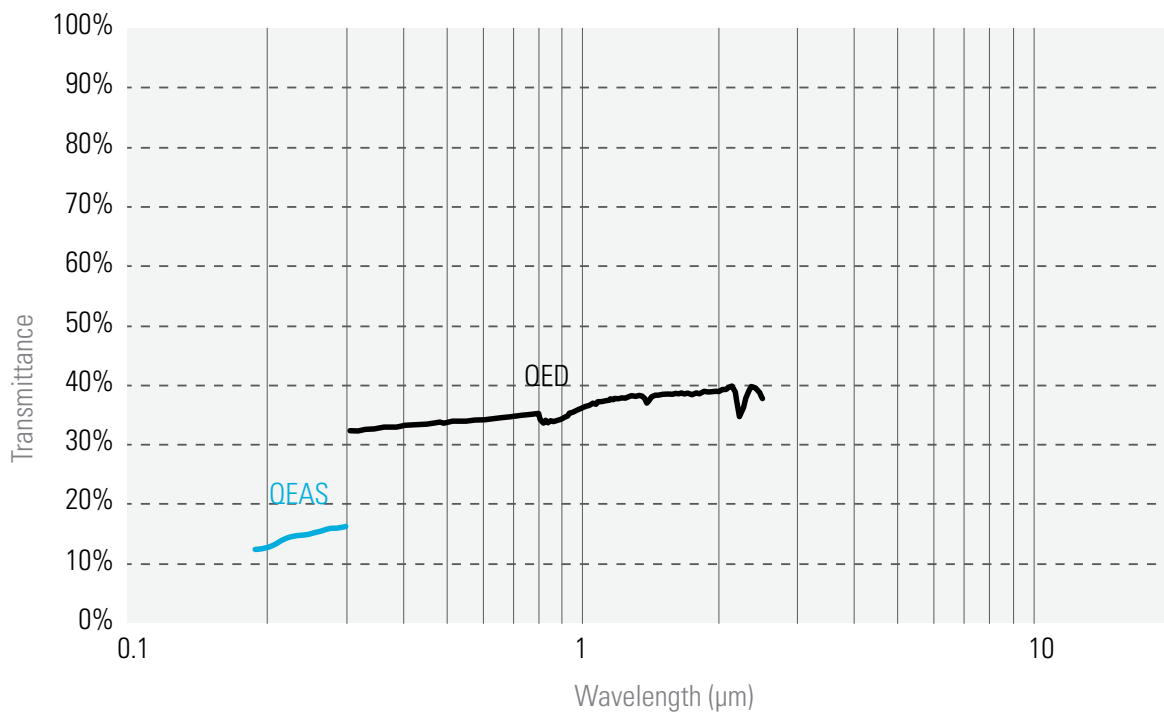

# PRESENTATION

## OVERVIEW OF THE DIFFERENT MODELS

Models start from a few nW to 500 W, for powers higher than 500 W, see the High Power Detectors section on page **94**

MONITORS

ENERGY DETECTORS

POWER DETECTORS

HIGH POWER SOLUTIONS

PHOTO DETECTORS

THZ DETECTORS

OEM DETECTORS

SPECIAL PRODUCTS

BEAM DIAGNOSTICS

Available with  
  
*integra*



### XLP12

- Low Power Thermopile  
Sensitivity of 200 mV/W  
Noise Level of  $\pm 0.5 \mu\text{W}$
- Minimal Thermal Drift of  $6 \mu\text{W}/^\circ\text{C}$
- IR Filter Available
- Available with volume absorber for short pulses

■ LOW POWER THERMOPILE 1  $\mu\text{W}$  NOISE LEVEL

See page **62**

Available with  
  
*integra*



### UP-H

- Standard (Broadband) Coating
- Available in 4 sizes:  
12 mm  $\varnothing$  25 mm  $\varnothing$   
19 mm  $\varnothing$  55 mm  $\varnothing$
- Available with 5 Cooling Modules:  
Convection (S, H or L)  
Fan (F)  
Water (W)

■ STANDARD COATING  
■ 4 SIZES  
■ 5 COOLING MODULES  
■ UP TO 500 W

See pages **64 to 70**

Available with  
  
*integra*



### UP-W

- High Damage Threshold Coating  
(100 kW/cm<sup>2</sup>)
- 17 or 50 mm  $\varnothing$  Aperture
- Perfect for:**  
UV lasers, very fast lasers  
and small beams

■ HIGH AVG OR PEAK POWER DENSITIES

See page **72 to 76**

# PRESENTATION

Available with  
  
 integra

## UP-VR

- High Peak Power Volume Absorbers
- 18 or 55 mm Ø Aperture

- SPECIFICALLY DESIGNED FOR HIGH ENERGY
- SOLID STATE LASERS
- HIGH AVG OR PEAK POWER DENSITIES



See pages **78 to 80**

Available with  
  
 integra

## UM-B

- Small Compact Detector
- 9 mm Ø Aperture
- Very Low Noise Level, down to 5 nW using a pyroelectric sensor \*

- ULTRA-LOW POWER PYROELECTRIC
- 5 nW NOISE LEVEL



See page **84**

\* Chopper needed for CW lasers.

## FLASH-IPL

- For sources up to 350 J
- Fast Responses: 5 sec measurement times with most of the models
- Rugged Devices: All-metal body, High Damage Thresholds

- HANDHELD LASER PROBES
- IPL: FOR SOURCES UP TO 350 J
- FIXED HANDLE OR SOFT CABLE



See page **86**

## COMPARISON TABLE

 Available with INTEGRA all-in-one detector + meter

MODEL	PMAX	PMAX (1 MIN)	NOISE LEVEL	EMAX	λMIN	λMAX	ABSORBER TYPE	APERTURE	SEE PAGE
UM9B-BL-D0	25 mW	25 mW	5 nW	N/A	100 nm	20 μm	Radiometer	9 mm Ø	84
XLP12-3S-H2	3 W	3 W	0.5 μW	5 J	190 nm	20 μm	Broadband	12 mm Ø	62
XLPF12-3S-H2	3 W	3 W	0.5 μW	5 J	280 nm	2.1 μm	Broadband	12 mm Ø	62
XLP12-3S-VP	3 W	3 W	0.5 μW	—	250 nm	20 μm	Volume Abs.	12 mm Ø	62
UP17P-6S-H5	6 W	7 W	1 mW	15 J	190 nm	20 μm	Broadband	17 mm Ø	72
UP17P-6S-W5	6 W	7 W	1 mW	200 J	190 nm	10 μm	High Threshold	17 mm Ø	72
UP12E-10S-H5	10 W	20 W	1 mW	5 J	190 nm	20 μm	Broadband	12 mm Ø	64
UP19K-15S-H5	15 W	30 W	1 mW	15 J	190 nm	20 μm	Broadband	19 mm Ø	66
UP25T-15S-H12	15 W	15 W	10 mW	40 J	190 nm	20 μm	Broadband	25 mm Ø	68
UP19K-15S-W5	15 W	30 W	1 mW	200 J	190 nm	10 μm	High Threshold	17 mm Ø	66
UP19K-15S-VR	15 W	20 W	2 mW	40 J	190 nm	2.5 μm	Volume Abs.	18 mm Ø	78
UP12E-20H-H5	20 W	40 W	1 mW	5 J	190 nm	20 μm	Broadband	12 mm Ø	64
UP19K-30H-H5	30 W	60 W	1 mW	15 J	190 nm	20 μm	Broadband	19 mm Ø	66
UP19K-30H-W5	30 W	60 W	1 mW	200 J	190 nm	10 μm	High Threshold	17 mm Ø	74
UP19K-30H-VR	30 W	35 W	2 mW	40 J	190 nm	2.5 μm	Volume Abs.	18 mm Ø	78
UP25N-40S-H9	40 W	80 W	3 mW	40 J	190 nm	20 μm	Broadband	25 mm Ø	68
UP55N-40S-H9	40 W	80 W	5 mW	200 J	190 nm	20 μm	Broadband	55 mm Ø	70
UP50N-40S-W9	40 W	80 W	5 mW	500 J	190 nm	10 μm	High Threshold	50 mm Ø	76
UP19K-50L-H5	50 W	90 W	1 mW	15 J	190 nm	20 μm	Broadband	19 mm Ø	66
UP19K-50L-W5	50 W	85 W	1 mW	200 J	190 nm	10 μm	High Threshold	17 mm Ø	74
UP19K-50F-W5	50 W	85 W	1 mW	200 J	190 nm	10 μm	High Threshold	17 mm Ø	74
UP19K-50W-W5	50 W	85 W	1 mW	200 J	190 nm	10 μm	High Threshold	17 mm Ø	74
UP50N-50H-W9	50 W	85 W	5 mW	500 J	190 nm	10 μm	High Threshold	50 mm Ø	76
UP50N-50F-W9	50 W	85 W	5 mW	500 J	190 nm	10 μm	High Threshold	50 mm Ø	76
UP50M-50W-W9	50 W	85 W	5 mW	500 J	190 nm	10 μm	High Threshold	50 mm Ø	76
UP55N-50S-VR	50 W	50 W	15 mW	500 J	190 nm	2.5 μm	Volume Abs.	55 mm Ø	80
UP12E-70W-H5	70 W	110 W	1 mW	5 J	190 nm	20 μm	Broadband	12 mm Ø	64
UP25N-100H-H9	100 W	200 W	3 mW	40 J	190 nm	20 μm	Broadband	25 mm Ø	68
UP55N-100H-H9	100 W	200 W	5 mW	200 J	190 nm	20 μm	Broadband	55 mm Ø	70
UP55N-100H-VR	100 W	100 W	15 mW	500 J	190 nm	2.5 μm	Volume Abs.	55 mm Ø	80
UP19K-110F-H9	110 W	150 W	3 mW	25 J	190 nm	20 μm	Broadband	19 mm Ø	66
UP19K-150W-H5	150 W	190 W	1 mW	15 J	190 nm	20 μm	Broadband	19 mm Ø	66
UP55N-150F-VR	150 W	150 W	15 mW	500 J	190 nm	2.5 μm	Volume Abs.	55 mm Ø	80
UP19K-200W-H9	200 W	200 W	3 mW	25 J	190 nm	20 μm	Broadband	19 mm Ø	66
UP55M-200W-VR	200 W	200 W	15 mW	500 J	190 nm	2.5 μm	Volume Abs.	55 mm Ø	80
UP25T-250W-H12	250 W	250 W	10 mW	40 J	190 nm	20 μm	Broadband	25 mm Ø	68
UP25N-250F-H12	250 W	300 W	10 mW	40 J	190 nm	20 μm	Broadband	25 mm Ø	68
UP55N-300F-H12	300 W	300 W	15 mW	200 J	190 nm	20 μm	Broadband	55 mm Ø	70
UP25M-350W-H12	350 W	350 W	10 mW	40 J	190 nm	20 μm	Broadband	25 mm Ø	68
UP55M-500W-H12	500 W	500 W	15 mW	200 J	190 nm	20 μm	Broadband	55 mm Ø	70
FLASH-500-55-W-IPL	500 W	N/A	100 mW	350 J	190 nm	2.5 μm	Broadband	55 mm Ø	86

# COMPARISON TABLE

## POWER RANGES

You can use the graph below to compare the power ranges of our pyroelectric and thermopile power detectors. Ranges go from the noise level to the maximum power reading.

Table 1.  
Comparison of the power ranges of the pyroelectric and thermopile power detectors

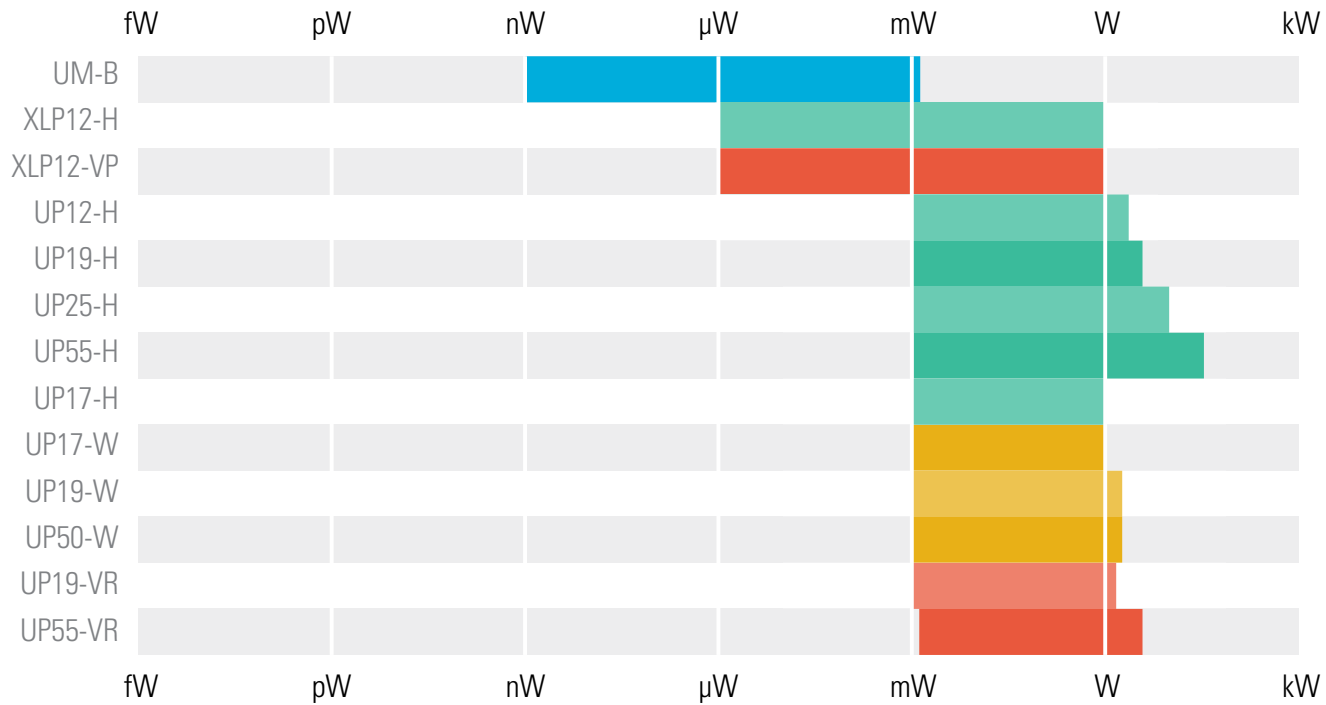

**Broadband Radiometer (Pyro-Based)**  
(Low Powers, Up to 50 mW/cm²)

**High Damage Threshold, for Small Beams**  
(Up to 100 kW/cm²)

**Broadband Absorber**  
(Mid to High Powers, Up to 45 kW/cm²)

**Volume Absorber, for Intense Pulses**  
(Up to 4 J/cm² for Short Pulses)



# XLP12

12 mm Ø, 0.5 μW - 3 W – Low Power Thermopile



## FEATURES

1. **LOW POWER THERMOPILE**  
Noise level of a photo detector with the large bandwidth and high power capacity of a thermal device
2. **MINIMAL THERMAL DRIFT**  
Only 6 μW/°C (with the IR filter)
3. **HIGH SENSITIVITY**  
200 mV/W (without the IR filter)
4. **SPECIAL MODEL FOR ULTRASHORT PULSES**  
VP (Volume Absorber) version is perfect for low power lasers with ultrashort pulses (ps and fs)
5. **IR FILTER (XLPF12 MODEL)**  
Removes unwanted IR interference
6. **ISOLATION TUBE**  
Eliminates power fluctuations created by air turbulence
7. **SMART INTERFACE**  
Containing all the calibration data

## AVAILABLE MODELS



XLP12-3S-H2  
(3W-Broadband)



XLPF12-3S-H2  
(3W-Broadband-IR Filter)



XLP12-3S-VP  
(3W-Volume Absorber)

## ACCESSORIES



Stand with Steel Post  
(Model Number: 200160)



Extension Cables  
(4, 15, 20 or 25 m)



IR Filter  
(Mounted)



Fiber Adaptors & Connectors  
(FC, SC, ST and SMA)



Pelican Carrying Case

## SEE ALSO

HOW IT WORKS	14
CALIBRATION	6
TECHNICAL DRAWINGS	88
ABSORPTION CURVES	92
COMPATIBLE MONITORS	
MAESTRO	20
TUNER	24
UNO	26
S-LINK	28
P-LINK	30
M-LINK	32
LIST OF ALL ACCESSORIES	184

## APPLICATION NOTE

MEASURING LASER POWER WITH A THERMOPILE DETECTOR: THE BASICS! [202175](#)

MONITORS

ENERGY DETECTORS

POWER DETECTORS

HIGH POWER SOLUTIONS

PHOTO DETECTORS

THZ DETECTORS

OEM DETECTORS

SPECIAL PRODUCTS

BEAM DIAGNOSTICS

## XLP12



\*Also traceable to NRC-CNRC

## SPECIFICATIONS

	XLP12-3S-H2	XLFP12-3S-H2	XLP12-3S-VP			
<b>MAX AVERAGE POWER (CONTINUOUS / 1 MINUTE)</b>	3 W / 3 W Broadband Absorber	3 W / 3 W Broadband Absorber, with IR Filter	3 W / 3 W Volume Absorber			
<b>EFFECTIVE APERTURE</b>	12 mm Ø	12 mm Ø	12 mm Ø			
<b>COOLING METHOD</b>	Convection	Convection	Convection			
<b>MEASUREMENT CAPABILITY</b>						
Spectral Range	0.19 – 20 µm *	0.28 – 2.1 µm <sup>a</sup>	0.25 – 20 µm *			
Noise Equivalent Power <sup>b</sup>	0.5 µW	0.5 µW	0.5 µW			
Thermal Drift <sup>c</sup>	12 µW/°C	6 µW/°C	12 µW/°C			
Rise Time (nominal) <sup>d</sup>	2.5 sec	2.5 sec	3 sec			
Sensitivity (typ into 100 kΩ load) <sup>e</sup>	200 mV/W	180 mV/W	220 mV/W			
Calibration Uncertainty <sup>f</sup>	±2.5 %	±2.5 %	±2.5 %			
Repeatability	±0.5 %	±0.5 %	±0.5 %			
<b>Energy Mode</b>						
Sensitivity	25 mV/J	22.5 mV/J	---			
Maximum Measurable Energy <sup>g</sup>	5 J	5 J	---			
Noise Equivalent Energy <sup>b</sup>	12 µJ	12 µJ	---			
Minimum Repetition Period	16 sec	16 sec	---			
Maximum Pulse Width	300 ms	300 ms	---			
Accuracy with energy calibration option	±5 %	±5 %	---			
<b>DAMAGE THRESHOLDS</b>						
Maximum Average Power Density <sup>h</sup>	1 kW/cm <sup>2</sup>	1 kW/cm <sup>2</sup>	30 W/cm <sup>2</sup> @ 1064 nm 8 W/cm <sup>2</sup> @ 532 nm 4 W/cm <sup>2</sup> @ 355 nm			
<b>Pulsed Laser Damage Thresholds</b>						
	Max Energy Dens.	Peak Power Dens.	Max Energy Dens.	Peak Power Dens.	Max Energy Dens.	Peak Power Dens.
1064 nm, 360 µs, 5 Hz	5 J/cm <sup>2</sup>	14 kW/cm <sup>2</sup>	5 J/cm <sup>2</sup>	14 kW/cm <sup>2</sup>	---	---
1064 nm, 7 ns, 10 Hz	1 J/cm <sup>2</sup>	143 MW/cm <sup>2</sup>	1 J/cm <sup>2</sup>	143 MW/cm <sup>2</sup>	4 J/cm <sup>2</sup>	571 MW/cm <sup>2</sup>
532 nm, 7 ns, 10 Hz	0.6 J/cm <sup>2</sup>	86 MW/cm <sup>2</sup>	0.6 J/cm <sup>2</sup>	86 MW/cm <sup>2</sup>	3 J/cm <sup>2</sup>	429 MW/cm <sup>2</sup>
355 nm, 7 ns, 10 Hz	---	---	---	---	1 J/cm <sup>2</sup>	143 MW/cm <sup>2</sup>
266 nm, 7 ns, 10 Hz	0,3 J/cm <sup>2</sup>	43 MW/cm <sup>2</sup>	0,3 J/cm <sup>2</sup>	43 MW/cm <sup>2</sup>	---	---
<b>PHYSICAL CHARACTERISTICS</b>						
Effective Aperture	12 mm Ø	12 mm Ø	12 mm Ø	12 mm Ø	12 mm Ø	12 mm Ø
Absorber (High Damage Threshold)	H2	H2	H2	H2	VP (Volume Absorber)	VP (Volume Absorber)
Dimensions	73H x 73W x 20D mm (72D mm with tube)	73H x 73W x 28D mm (80D mm with tube)	73H x 73W x 28D mm (80D mm with tube)	73H x 73W x 28D mm (80D mm with tube)	73H x 73W x 20D mm (72D mm with tube)	73H x 73W x 20D mm (72D mm with tube)
Weight (head only)	0.31 kg	0.32 kg	0.32 kg	0.32 kg	0.32 kg	0.32 kg
<b>ORDERING INFORMATION</b>						
Product Name	XLP12-3S-H2	XLFP12-3S-H2	XLP12-3S-VP	XLP12-3S-VP	XLP12-3S-VP	XLP12-3S-VP
Product Number (Including stand)	201035	201078	202228	202228	202228	202228
Add Extension for INTEGRA	-INT	-INT	-INT	-INT	-INT	-INT
Product Number (Including stand)	202608	202610	202610	202610	202610	202610

Les spécifications peuvent être modifiées sans préavis

\* For the calibrated spectral range, see the user manual.

a. This spectral range refers to the calibration traceability. For details, please contact us at: info@gentec-eo.com.

b. Nominal value, actual value depends on electrical noise in the measurement system.

c. With Gentec-EO MAESTRO.

d. With Gentec-EO MAESTRO, UNO, P-LINK, TUNER and S-LINK monitors.

e. Maximum output voltage = sensitivity x maximum power.

f. Including linearity with power.

g. For 360 µs pulses. Higher pulse energy possible when customized for long pulses (ms), less for short pulses (ns).

h. At 1064 nm, 1 W CW.



# UP12-H

12 mm Ø, 1 mW - 110 W

MONITORS

ENERGY DETECTORS

POWER DETECTORS

HIGH POWER SOLUTIONS

PHOTO DETECTORS

THZ DETECTORS

OEM DETECTORS

SPECIAL PRODUCTS

BEAM DIAGNOSTICS



## KEY FEATURES

- 1. MODULAR CONCEPT**  
Increase the power capability of your detector: 3 different cooling modules
- 2. HIGH PERFORMANCE**  
Fast Rise Time (0.3 sec)  
High Damage Threshold (36 kW/cm<sup>2</sup>)
- 3. COMPACT DESIGN**  
Only 14 mm thick (10S model)
- 4. ENERGY MODE**  
Measure single shot energy up to 5 J
- 5. SMART INTERFACE**  
Containing all the calibration data

## AVAILABLE MODELS



UP12E-10S-H5  
(10W-Standalone)



UP12E-20H-H5  
(20W-Heatsink)



UP12E-70W-H5  
(70W-Water-Cooled)

## ACCESSORIES



Stand with Steel Post  
(Model Number: 200160)



Extension Cables  
(4, 15, 20 or 25 m)



Fiber Adaptors and Connectors  
(FC, SC or SMA)



Pelican Carrying Case

## SEE ALSO

HOW IT WORKS	14
CALIBRATION	6
TECHNICAL DRAWINGS	88
ABSORPTION CURVES	92
OEM DETECTORS	134
COMPATIBLE MONITORS	
MAESTRO	20
TUNER	24
UNO	26
S-LINK	28
P-LINK	30
M-LINK	32
LIST OF ALL ACCESSORIES	184
APPLICATION NOTE	
MEASURING LASER POWER WITH A THERMOPILE DETECTOR: THE BASICS!	202175

## UP12-H



\*Also traceable to NRC-CNRC

## SPECIFICATIONS

	UP12E-10S-H5	UP12E-20H-H5	UP12E-70W-H5
<b>MAX AVERAGE POWER (CONTINUOUS / 1 MINUTE)</b>	10 W / 20 W	20 W / 40 W	70 W <sup>f</sup> / 110 W <sup>f</sup>
<b>EFFECTIVE APERTURE</b>	12 mm Ø	12 mm Ø	12 mm Ø
<b>COOLING METHOD</b>	Convection	Heatsink	Water-Cooled
<b>MEASUREMENT CAPABILITY</b>			
Spectral Range *	0.19 – 20 µm	0.19 – 20 µm	0.19 – 20 µm
Noise Equivalent Power <sup>a</sup>	1 mW	1 mW	1 mW
Rise Time (nominal) <sup>b</sup>	0.3 sec	0.3 sec	0.3 sec
Sensitivity (typ into 100 kΩ load) <sup>c</sup>	0.53 mV/W	0.53 mV/W	0.53 mV/W
Calibration Uncertainty <sup>d</sup>	±2.5 %	±2.5 %	±2.5 %
Repeatability	±0.5 %	±0.5 %	±0.5 %
<b>Energy Mode</b>			
Sensitivity	0.84 mV/J	0.84 mV/J	0.84 mV/J
Maximum Measurable Energy <sup>e</sup>	5 J	5 J	5 J
Noise Equivalent Energy <sup>a</sup>	0.02 J	0.02 J	0.02 J
Minimum Repetition Period	1.5 sec	1.5 sec	1.5 sec
Maximum Pulse Width	50 ms	50 ms	50 ms
Accuracy with energy calibration option	±5 %	±5 %	±5 %
<b>DAMAGE THRESHOLDS</b>			
Maximum Average Power Density <sup>a</sup>	36 kW/cm <sup>2</sup>	36 kW/cm <sup>2</sup>	36 kW/cm <sup>2</sup>
Pulsed Laser Damage Thresholds	Max Energy Density		Peak Power Density
1064 nm, 360 µs, 5 Hz	5 J/cm <sup>2</sup>		14 kW/cm <sup>2</sup>
1064 nm, 7 ns, 10 Hz	1 J/cm <sup>2</sup>		143 MW/cm <sup>2</sup>
532 nm, 7 ns, 10 Hz	0.6 J/cm <sup>2</sup>		86 MW/cm <sup>2</sup>
266 nm, 7 ns, 10 Hz	0.3 J/cm <sup>2</sup>		43 MW/cm <sup>2</sup>
<b>PHYSICAL CHARACTERISTICS</b>			
Effective Aperture	12 mm Ø	12 mm Ø	12 mm Ø
Absorber (High Damage Threshold)	H5	H5	H5
Dimensions	38H x 38W x 14D mm	38H x 38W x 45D mm	38H x 38W x 32D mm
Weight (head only)	0.13 kg	0.15 kg	0.19 kg
<b>ORDERING INFORMATION</b>			
Product Name	UP12E-10S-H5	UP12E-20H-H5	UP12E-70W-H5
Product Number (Including stand)	200384	200386	200390
Add Extension for INTEGRA	-INT	-INT	-INT
Product Number (Including stand)	202612	202614	

Specifications are subject to change without notice

\* For the calibrated spectral range, see the user manual.

- a. Nominal value, actual value depends on electrical noise in the measurement system.  
 b. With Gentec-EO MAESTRO, UNO, P-LINK, TUNER and S-LINK monitors.  
 c. Maximum output voltage = sensitivity x maximum power.  
 d. Including linearity with power.  
 e. For 360 µs pulses. Higher pulse energy possible when customized for long pulses (ms), less for short pulses (ns).  
 f. Minimum cooling flow 0.5 liters/min, water temperature ≤ 22°C, 1/8 NPT compression fittings for 1/4 inch semi-rigid tube. Contact Gentec-EO for clean deionized water cooling module option.  
 g. At 1064 nm, 10 W CW.



# UP19-H

19 mm Ø, 1 mW - 200 W



## KEY FEATURES

1. **MODULAR CONCEPT**  
Increase the power capability of your detector: 5 different cooling modules
2. **HIGH PERFORMANCE**  
Fast Rise Time (0.6 sec)  
High Damage Threshold (45 kW/cm<sup>2</sup>)
3. **COMPACT DESIGN**  
Only 20.6 mm thick (15S model)
4. **ENERGY MODE**  
Measure single shot energy up to 15 J
5. **SMART INTERFACE**  
Containing all the calibration data

## AVAILABLE MODELS



UP19K-15S-H5  
(15W-Standalone)



UP19K-30H-H5  
(30W-Heatsink)



UP19K-50L-H5  
(50W-Large Heatsink)



UP19K-110F-H9  
(110W-Fan-Cooled)



UP19K-150W-H5  
(150W-Water-Cooled)



UP19K-200W-H9  
(200W-Water-Cooled)

## ACCESSORIES



Stand with Steel Post  
(Model Number: 200160)



Extension Cables  
(4, 15, 20 or 25 m)



Isolation Tube  
(Model Number: 202376)



Fiber Adaptors and Connectors  
(FC, SC or SMA)



12V Power Supply  
(Model Number: 200130)



Pelican Carrying Case

## SEE ALSO

HOW IT WORKS	14
CALIBRATION	6
TECHNICAL DRAWINGS	88
ABSORPTION CURVES	92
OEM DETECTORS	134
COMPATIBLE MONITORS	
MAESTRO	20
TUNER	24
UNO	26
S-LINK	28
P-LINK	30
M-LINK	32
LIST OF ALL ACCESSORIES	184
APPLICATION NOTE	
MEASURING LASER POWER WITH A THERMOPILE DETECTOR: THE BASICS!	202175

MONITORS

ENERGY DETECTORS

POWER DETECTORS

HIGH POWER SOLUTIONS

PHOTO DETECTORS

THZ DETECTORS

OEM DETECTORS

SPECIAL PRODUCTS

BEAM DIAGNOSTICS

## UP19-H



\*Also traceable to NRC-CNRC

## SPECIFICATIONS

	UP19K-15S-H5	UP19K-30H-H5	UP19K-50L-H5	UP19K-110F-H9	UP19K-150W-H5	UP19K-200W-H9
<b>MAX AVERAGE POWER (CONTINUOUS / 1 MINUTE)</b>	15 W / 30 W	30 W / 60 W	50 W / 90 W	110 W / 150 W	150 W <sup>f</sup> / 190 W <sup>f</sup>	200 W <sup>f</sup> / 200 W <sup>f</sup>
<b>EFFECTIVE APERTURE</b>	19 mm Ø	19 mm Ø	19 mm Ø	19 mm Ø	19 mm Ø	19 mm Ø
<b>COOLING METHOD</b>	Convection	Heatsink	Large Heatsink	Fan-Cooled	Water-Cooled	Water-Cooled
<b>MEASUREMENT CAPABILITY</b>						
Spectral Range *	0.19 – 20 µm	0.19 – 20 µm	0.19 – 20 µm	0.19 – 20 µm	0.19 – 20 µm	0.19 – 20 µm
Noise Equivalent Power <sup>a</sup>	1 mW	1 mW	1 mW	3 mW	1 mW	3 mW
Rise Time (nominal) <sup>b</sup>	0.6 sec	0.6 sec	0.6 sec	1.5 sec	0.6 sec	1.5 sec
Sensitivity (typ into 100 kΩ load) <sup>c</sup>	0.65 mV/W	0.65 mV/W	0.65 mV/W	0.23 mV/W	0.65 mV/W	0.23 mV/W
Calibration Uncertainty <sup>d</sup>	±2.5 %	±2.5 %	±2.5 %	±2.5 %	±2.5 %	±2.5 %
Repeatability	±0.5 %	±0.5 %	±0.5 %	±0.5 %	±0.5 %	±0.5 %
<b>Energy Mode</b>						
Sensitivity	0.65 mV/J	0.65 mV/J	0.65 mV/J	0.23 mV/J	0.65 mV/J	0.23 mV/J
Maximum Measurable Energy <sup>e</sup>	15 J	15 J	15 J	25 J	15 J	25 J
Noise Equivalent Energy <sup>a</sup>	0.02 J	0.02 J	0.02 J	0.06 J	0.02 J	0.06 J
Minimum Repetition Period	4 sec	4 sec	4 sec	4 sec	4 sec	4 sec
Maximum Pulse Width	88 ms	88 ms	88 ms	88 ms	88 ms	88 ms
Accuracy with energy calibration option	±5 %	±5 %	±5 %	±5 %	±5 %	±5 %
<b>DAMAGE THRESHOLDS</b>						
Maximum Average Power Density <sup>a</sup>	36 kW/cm <sup>2</sup>	36 kW/cm <sup>2</sup>	36 kW/cm <sup>2</sup>	45 kW/cm <sup>2</sup>	36 kW/cm <sup>2</sup>	45 kW/cm <sup>2</sup>
Pulsed Laser Damage Thresholds	Max Energy Density			Peak Power Density		
1064 nm, 360 µs, 5 Hz	5 J/cm <sup>2</sup> (H5), 9 J/cm <sup>2</sup> (H9)			14 kW/cm <sup>2</sup> (H5), 25 kW/cm <sup>2</sup> (H9)		
1064 nm, 7 ns, 10 Hz	1 J/cm <sup>2</sup>			143 MW/cm <sup>2</sup>		
532 nm, 7 ns, 10 Hz	0.6 J/cm <sup>2</sup>			86 MW/cm <sup>2</sup>		
266 nm, 7 ns, 10 Hz	0.3 J/cm <sup>2</sup>			43 MW/cm <sup>2</sup>		
<b>PHYSICAL CHARACTERISTICS</b>						
Effective Aperture	19 mm Ø	19 mm Ø	19 mm Ø	19 mm Ø	19 mm Ø	19 mm Ø
Absorber (High Damage Threshold)	H5	H5	H5	H9	H5	H9
Dimensions	50H x 50W x 20.6D mm	50H x 50W x 56.3D mm	76.2H x 76.2W x 74.7D mm	54.2H x 54.2W x 55.6D mm	50H x 50W x 33D mm	50H x 50W x 33D mm
Weight (head only)	0.16 kg	0.21 kg	0.48 kg	0.25 kg	0.24 kg	0.24 kg
<b>ORDERING INFORMATION</b>						
Product Name	UP19K-15S-H5	UP19K-30H-H5	UP19K-50L-H5	UP19K-110F-H9	UP19K-150W-H5	UP19K-200W-H9
Product Number (Including stand)	200173	200174	200175	200996	200177	200583
Add Extension for INTEGRA	-INT	-INT	-INT	-INT	-INT	-INT
Product Number (Including stand)	202616	202618	202620	202622	202624	

Specifications are subject to change without notice

\* For the calibrated spectral range, see the user manual.

- a. Nominal value, actual value depends on electrical noise in the measurement system.  
 b. With Gentec-EO MAESTRO, UNO, P-LINK, TUNER and S-LINK monitors.  
 c. Maximum output voltage = sensitivity x maximum power.  
 d. Including linearity with power.  
 e. For 360 µs pulses. Higher pulse energy possible when customized for long pulses (ms), less for short pulses (ns).

- f. Minimum cooling flow 0.5 liters/min, water temperature ≤ 22°C, 1/8 NPT compression fittings for 1/4 inch semi-rigid tube.  
 Contact Gentec-EO for clean deionized water cooling module option.  
 g. At 1064 nm, 10 W CW.



# UP25-H

25 mm Ø, 3 mW - 350 W



## FEATURES

1. **MODULAR CONCEPT**  
Increase the power capability of your detector:  
4 different cooling modules
2. **HIGH PERFORMANCE**  
Fast Rise Time (1.3 sec)  
High Damage Threshold (45 kW/cm<sup>2</sup>)
3. **ENERGY MODE**  
Measure single shot energy up to 40 J
4. **SMART INTERFACE**  
Containing all the calibration data

## AVAILABLE MODELS



UP25N-40S-H9  
(40W-Standalone)



UP25N-100H-H9  
(100W-Heatsink)



UP25N-250F-H12  
(250W-Fan-Cooled)



UP25M-350W-H12  
(350W-Water-Cooled)

## ACCESSORIES



Stand with Steel Post  
(Model Number: 200234)



Extension Cables  
(4, 15, 20 or 25 m)



Fiber Adaptors and Connectors  
(FC, SC or SMA)



12V Power Supply  
(Model Number: 200130)



Pelican Carrying Case

## SEE ALSO

HOW IT WORKS	14
CALIBRATION	6
TECHNICAL DRAWINGS	88
ABSORPTION CURVES	92
OEM DETECTORS	134
COMPATIBLE MONITORS	
MAESTRO	20
TUNER	24
UNO	26
S-LINK	28
P-LINK	30
M-LINK	32
LIST OF ALL ACCESSORIES	184
APPLICATION NOTE	
MEASURING LASER POWER WITH A THERMOPILE DETECTOR: THE BASICS!	202175

MONITORS

ENERGY DETECTORS

POWER DETECTORS

HIGH POWER SOLUTIONS

PHOTO DETECTORS

THZ DETECTORS

OEM DETECTORS

SPECIAL PRODUCTS

BEAM DIAGNOSTICS

## UP25-H



\*Also traceable to NRC-CNRC

## SPECIFICATIONS

	UP25N-40S-H9	UP25N-100H-H9	UP25N-250F-H12	UP25M-350W-H12
<b>MAX AVERAGE POWER (CONTINUOUS / 1 MINUTE)</b>	40 W / 80 W	100 W / 200 W	250 W / 300 W	350 W <sup>f</sup> / 350 W <sup>f</sup>
<b>EFFECTIVE APERTURE</b>	25 mm Ø	25 mm Ø	25 mm Ø	25 mm Ø
<b>COOLING METHOD</b>	Convection	Heatsink	Fan-Cooled	Water-Cooled
<b>MEASUREMENT CAPABILITY</b>				
Spectral Range *	0.19 – 20 µm	0.19 – 20 µm	0.19 – 20 µm	0.19 – 20 µm
Noise Equivalent Power <sup>a</sup>	3 mW	3 mW	10 mW	10 mW
Rise Time (nominal) <sup>b</sup>	1.3 sec	1.3 sec	1.3 sec	1.3 sec
Sensitivity (typ into 100 kΩ load) <sup>c</sup>	0.23 mV/W	0.23 mV/W	0.1 mV/W	0.1 mV/W
Calibration Uncertainty <sup>d</sup>	±2.5 %	±2.5 %	±2.5 %	±2.5 %
Repeatability	±0.5 %	±0.5 %	±0.5 %	±0.5 %
Energy Mode				
Sensitivity	0.14 mV/J	0.14 mV/J	0.05 mV/J	0.05 mV/J
Maximum Measurable Energy <sup>e</sup>	40 J	40 J	40 J	40 J
Noise Equivalent Energy <sup>a</sup>	0.2 J	0.2 J	0.2 J	0.2 J
Minimum Repetition Period	4.6 sec	4.6 sec	11.5 sec	11.5 sec
Maximum Pulse Width	123 ms	123 ms	390 ms	390 ms
Accuracy with energy calibration option	±5 %	±5 %	±5 %	±5 %
<b>DAMAGE THRESHOLDS</b>				
Maximum Average Power Density				
1064 nm, 10 W, CW	45 kW/cm <sup>2</sup>	45 kW/cm <sup>2</sup>	45 kW/cm <sup>2</sup>	45 kW/cm <sup>2</sup>
10.6 µm, 10 W, CW	14 kW/cm <sup>2</sup>	14 kW/cm <sup>2</sup>	14 kW/cm <sup>2</sup>	14 kW/cm <sup>2</sup>
Pulsed Laser Damage Thresholds	Max Energy Density		Peak Power Density	
1064 nm, 360 µs, 5 Hz	9 J/cm <sup>2</sup>		25 kW/cm <sup>2</sup>	
1064 nm, 7 ns, 10 Hz	1 J/cm <sup>2</sup>		143 MW/cm <sup>2</sup>	
532 nm, 7 ns, 10 Hz	0.6 J/cm <sup>2</sup>		86 MW/cm <sup>2</sup>	
266 nm, 7 ns, 10 Hz	0.3 J/cm <sup>2</sup>		43 MW/cm <sup>2</sup>	
<b>PHYSICAL CHARACTERISTICS</b>				
Effective Aperture	25 mm Ø	25 mm Ø	25 mm Ø	25 mm Ø
Absorber (High Damage Threshold)	H9	H9	H12	H12
Dimensions	89H x 89W x 32D mm	89H x 89W x 106D mm	89H x 89W x 116D mm	89H x 89W x 40D mm
Weight (head only)	0.68 kg	0.99 kg	1.44 kg	0.87 kg
<b>ORDERING INFORMATION</b>				
Product Name	UP25N-40S-H9	UP25N-100H-H9	UP25N-250F-H12	UP25M-350W-H12
Product Number (including stand)	200198	200202	201154	201894
Add Extension for INTEGRA	-INT	-INT	-INT	-INT

Specifications are subject to change without notice

\* For the calibrated spectral range, see the user manual.

- a. Nominal value, actual value depends on electrical noise in the measurement system.  
b. With Gentec-EO MAESTRO, UNO, P-LINK, TUNER and S-LINK monitors.  
c. Maximum output voltage = sensitivity x maximum power.  
d. Including linearity with power.  
e. For 360 µs pulses. Higher pulse energy possible when customized for long pulses (ms), less for short pulses (ns).  
f. Minimum cooling flow 1.5 liters/min, water temperature ≤ 22°C, 1/8 NPT compression fittings for 1/4 inch semi-rigid tube.  
Contact Gentec-EO for clean deionized water cooling module option.



# UP55-H

55 mm Ø, 5 mW - 500 W



## FEATURES

1. **MODULAR CONCEPT**  
Increase the power capability of your detector: 4 different cooling modules
2. **HIGH PERFORMANCE**
  - Fast Rise Time (2 sec)
  - High Damage Threshold (45 kW/cm<sup>2</sup>)
3. **COMPACT DESIGN**  
Only 32 mm thick (40S model)
4. **ENERGY MODE**  
Measure single shot energy up to 200 J
5. **SMART INTERFACE**  
Containing all the calibration data

## AVAILABLE MODELS



UP55N-40S-H9  
(40W-Standalone)



UP55N-100H-H9  
(100W-Heatsink)



UP55N-300F-H12  
(300W-Fan-Cooled)



UP55M-500W-H12  
(500W-Water-Cooled)

## ACCESSORIES



Additional 9V Power Supply  
(Model Number: 200960)



Extension Cables  
(4, 15, 20 or 25 m)



Fiber Adaptors and Connectors  
(FC, SC or SMA)



3-Port Fiber Cylinder with  
Adaptors and Plug



12V Power Supply  
(Model Number: 200130)



Pelican Carrying Case

## SEE ALSO

HOW IT WORKS	14
CALIBRATION	6
TECHNICAL DRAWINGS	88
ABSORPTION CURVES	92
OEM DETECTORS	134
COMPATIBLE MONITORS	
MAESTRO	20
TUNER	24
UNO	26
S-LINK	28
P-LINK	30
M-LINK	32
LIST OF ALL ACCESSORIES	184
APPLICATION NOTE	
MEASURING LASER POWER WITH A THERMOPILE DETECTOR: THE BASICS!	202175

MONITORS

ENERGY DETECTORS

POWER DETECTORS

HIGH POWER SOLUTIONS

PHOTO DETECTORS

THZ DETECTORS

OEM DETECTORS

SPECIAL PRODUCTS

BEAM DIAGNOSTICS

## UP55-H



\*Also traceable to NRC-CNRC

## SPECIFICATIONS

	UP55N-40S-H9	UP55N-100H-H9	UP55N-300F-H12	UP55M-500W-H12
<b>MAX AVERAGE POWER (CONTINUOUS / 1 MINUTE)</b>	40 W / 80 W	100 W / 200 W	300 W / 300 W	500 W <sup>f</sup> / 500 W <sup>f</sup>
<b>EFFECTIVE APERTURE</b>	55 mm Ø	55 mm Ø	55 mm Ø	55 mm Ø
<b>COOLING METHOD</b>	Convection	Heatsink	Fan-Cooled	Water-Cooled
<b>MEASUREMENT CAPABILITY</b>				
Spectral Range *	0.19 – 20 µm	0.19 – 20 µm	0.19 – 20 µm	0.19 – 20 µm
Noise Equivalent Power <sup>a</sup>	5 mW	5 mW	15 mW	15 mW
Rise Time (nominal) <sup>b</sup>	2 sec	2 sec	2 sec	2 sec
Sensitivity (typ into 100 kΩ load) <sup>c</sup>	0.12 mV/W	0.12 mV/W	0.06 mV/W	0.06 mV/W
Calibration Uncertainty <sup>d</sup>	±2.5 %	±2.5 %	±2.5 %	±2.5 %
Repeatability	±0.5 %	±0.5 %	±0.5 %	±0.5 %
Energy Mode				
Sensitivity	0.028 mV/J	0.028 mV/J	0.015 mV/J	0.015 mV/J
Maximum Measurable Energy <sup>e</sup>	200 J	200 J	200 J	200 J
Noise Equivalent Energy <sup>a</sup>	0.25 J	0.25 J	0.25 J	0.25 J
Minimum Repetition Period	11.1 sec	11.1 sec	12 sec	12 sec
Maximum Pulse Width	433 ms	433 ms	430 ms	430 ms
Accuracy with energy calibration option	±5 %	±5 %	±5 %	±5 %
<b>DAMAGE THRESHOLDS</b>				
Maximum Average Power Density				
1064 nm, 10 W, CW	45 kW/cm <sup>2</sup>	45 kW/cm <sup>2</sup>	45 kW/cm <sup>2</sup>	45 kW/cm <sup>2</sup>
10.6 µm, 10 W, CW	14 kW/cm <sup>2</sup>	14 kW/cm <sup>2</sup>	14 kW/cm <sup>2</sup>	14 kW/cm <sup>2</sup>
Pulsed Laser Damage Thresholds		Max Energy Density		Peak Power Density
1064 nm, 360 µs, 5 Hz		9 J/cm <sup>2</sup>		25 kW/cm <sup>2</sup>
1064 nm, 7 ns, 10 Hz		1 J/cm <sup>2</sup>		143 MW/cm <sup>2</sup>
532 nm, 7 ns, 10 Hz		0.6 J/cm <sup>2</sup>		86 MW/cm <sup>2</sup>
266 nm, 7 ns, 10 Hz		0.3 J/cm <sup>2</sup>		43 MW/cm <sup>2</sup>
<b>PHYSICAL CHARACTERISTICS</b>				
Effective Aperture	55 mm Ø	55 mm Ø	55 mm Ø	55 mm Ø
Absorber (High Damage Threshold)	H9	H9	H12	H12
Dimensions	89H x 89W x 32D mm	89H x 89W x 106D mm	89H x 89W x 116D mm	89H x 89W x 40D mm
Weight (head only)	0.62 kg	0.93 kg	1.41 kg	0.81 kg
<b>ORDERING INFORMATION</b>				
Product Name	UP55N-40S-H9	UP55N-100H-H9	UP55N-300F-H12	UP55M-500W-H12
Product Number (Including stand)	200218	200222	201160	201883
Add Extension for INTEGRA	-INT	-INT	-INT	-INT
Product Number (Including stand)	202626	202628	202630	

Specifications are subject to change without notice

\* For the calibrated spectral range, see the user manual.

a. Nominal value, actual value depends on electrical noise in the measurement system.

b. With Gentec-EO MAESTRO, UNO, P-LINK, TUNER and S-LINK monitors.

c. Maximum output voltage = sensitivity x maximum power.

d. Including linearity with power.

e. For 360 µs pulses. Higher pulse energy possible when customized for long pulses (ms), less for short pulses (ns).

f. Minimum cooling flow 1.5 liters/min, water temperature ≤ 22°C, 1/8 NPT compression fittings for 1/4 inch semi-rigid tube. Contact Gentec-EO for clean deionized water cooling module option.



# UP17-H/W

17 mm Ø, 1 mW - 7 W, Ultra Thin Casing



## KEY FEATURES

1. **ULTRA THIN CASING**  
Only 10.7 mm thick!
2. **CHOICE BETWEEN 2 ABSORBERS**
  - H5: 36 kW/cm<sup>2</sup>
  - W5: Unequalled 100 kW/cm<sup>2</sup>
3. **HIGH POWER TO SIZE RATIO**  
6 W continuous reading
4. **ENERGY MODE**  
Measure single shot energy up to 200 J (with the W5 version)
5. **SMART INTERFACE**  
Containing all the calibration data

## AVAILABLE MODELS



UP17P-6S-H5  
(6W-36 kW/cm<sup>2</sup>)



UP17P-6S-W5  
(6W-100 kW/cm<sup>2</sup>)

## ACCESSORIES



Stand with Steel Post  
(Model Number: 200160)



Extension Cables  
(4, 15, 20 or 25 m)



Pelican Carrying Case

## SEE ALSO

HOW IT WORKS	14
CALIBRATION	6
TECHNICAL DRAWINGS	88
ABSORPTION CURVES	92
COMPATIBLE MONITORS	
MAESTRO	20
TUNER	24
UNO	26
S-LINK	28
P-LINK	30
M-LINK	32
LIST OF ALL ACCESSORIES	184

## APPLICATION NOTE

MEASURING LASER POWER WITH A THERMOPILE DETECTOR: THE BASICS! [202175](#)

MONITORS

ENERGY DETECTORS

POWER DETECTORS

HIGH POWER SOLUTIONS

PHOTO DETECTORS

THZ DETECTORS

OEM DETECTORS

SPECIAL PRODUCTS

BEAM DIAGNOSTICS

# UP17-H/W



\*Also traceable to NRC-CNRC

## SPECIFICATIONS

	UP17P-6S-H5	UP17P-6S-W5		
<b>MAX AVERAGE POWER (CONTINUOUS / 1 MINUTE)</b>	6 W / 7 W	6 W / 7 W		
<b>EFFECTIVE APERTURE</b>	17 mm Ø	17 mm Ø		
<b>COOLING METHOD</b>	Convection	Convection		
<b>MEASUREMENT CAPABILITY</b>				
Spectral Range *	0.19 – 20 µm	0.19 – 10 µm		
Noise Equivalent Power <sup>a</sup>	1 mW	1 mW		
Rise Time (nominal) <sup>b</sup>	0.8 sec	1.4 sec		
Sensitivity (typ into 100 kΩ load) <sup>c</sup>	0.6 mV/W	0.6 mV/W		
Calibration Uncertainty <sup>d</sup>	±2.5 %	±2.5 %		
Repeatability	±0.5 %	±0.5 %		
Energy Mode				
Sensitivity	0.7 mV/J	0.2 mV/J		
Maximum Measurable Energy <sup>e</sup>	15 J	200 J		
Noise Equivalent Energy <sup>a</sup>	0.02 J	0.02 J		
Minimum Repetition Period	4 sec	5 sec		
Maximum Pulse Width	88 ms	133 ms		
Accuracy with energy calibration option	±5 %	±5 %		
<b>DAMAGE THRESHOLDS</b>				
Maximum Average Power Density <sup>f</sup>	36 kW/cm <sup>2</sup>	100 kW/cm <sup>2</sup>		
Pulsed Laser Damage Thresholds	Max Energy Density	Peak Power Density	Max Energy Density	Peak Power Density
1064 nm, 360 µs, 5 Hz	5 J/cm <sup>2</sup>	14 kW/cm <sup>2</sup>	100 J/cm <sup>2</sup>	667 kW/cm <sup>2</sup>
1064 nm, 7 ns, 10 Hz	1 J/cm <sup>2</sup>	143 MW/cm <sup>2</sup>	1.1 J/cm <sup>2</sup>	157 MW/cm <sup>2</sup>
532 nm, 7 ns, 10 Hz	0.6 J/cm <sup>2</sup>	86 MW/cm <sup>2</sup>	1.1 J/cm <sup>2</sup>	157 MW/cm <sup>2</sup>
266 nm, 7 ns, 10 Hz	0.3 J/cm <sup>2</sup>	43 MW/cm <sup>2</sup>	0.7 J/cm <sup>2</sup>	27 MW/cm <sup>2</sup>
<b>PHYSICAL CHARACTERISTICS</b>				
Effective Aperture	17 mm Ø	17 mm Ø		
Absorber (High Damage Threshold)	H5	W5		
Dimensions	46H x 46W x 10.7D mm	46H x 46W x 10.7D mm		
Weight (head only)	0.1 kg	0.1 kg		
<b>ORDERING INFORMATION</b>				
Product Name	UP17P-6S-H5	UP17P-6S-W5		
Product Number (Including stand)	201036	201037		
Add Extension for INTEGRA	-INT	-INT		

Specifications are subject to change without notice

\* For the calibrated spectral range, see the user manual.

- a. Nominal value, actual value depends on electrical noise in the measurement system.
- b. With Gentec-EO MAESTRO, UNO, P-LINK, TUNER and S-LINK monitors.
- c. Maximum output voltage = sensitivity x maximum power.
- d. Including linearity with power.
- e. For 360 µs pulses. Higher pulse energy possible when customized for long pulses (ms), less for short pulses (ns).
- f. At 1064 nm, 10 W CW.



# UP19-W

17 mm Ø, 1 mW - 85 W, 100 kW/cm<sup>2</sup>



## FEATURES

1. **MODULAR CONCEPT**  
Increase the power capability of your detector:  
5 different cooling modules
2. **VERY HIGH DAMAGE THRESHOLD**  
100 kW/cm<sup>2</sup> in average power density
3. **COMPACT DESIGN**  
Only 21 mm thick (15S model)
4. **ENERGY MODE**  
Measure single shot energy up to 200 J
5. **SMART INTERFACE**  
Containing all the calibration data

## AVAILABLE MODELS



UP19K-15S-W5  
(15W-Standalone)



UP19K-30H-W5  
(30W-Heatsink)



UP19K-50L-W5  
(50W-Large Heatsink)



UP19K-50F-W5  
(50W-Fan-Cooled)



UP19K-50W-W5  
(50W-Water-Cooled)

## ACCESSORIES



Stand with Steel Post  
(Model Number: 200160)



Extension Cables  
(4, 15, 20 or 25 m)



12V Power Supply  
(Model Number: 200130)



Pelican Carrying Case

## SEE ALSO

HOW IT WORKS	14
CALIBRATION	6
TECHNICAL DRAWINGS	88
ABSORPTION CURVES	92
OEM DETECTORS	134
COMPATIBLE MONITORS	
MAESTRO	20
TUNER	24
UNO	26
S-LINK	28
P-LINK	30
M-LINK	32
LIST OF ALL ACCESSORIES	184
APPLICATION NOTE	
MEASURING LASER POWER WITH A THERMOPILE DETECTOR: THE BASICS!	202175

MONITORS

ENERGY DETECTORS

POWER DETECTORS

HIGH POWER SOLUTIONS

PHOTO DETECTORS

THZ DETECTORS

OEM DETECTORS

SPECIAL PRODUCTS

BEAM DIAGNOSTICS

## UP19-W



\*Also traceable to NRC-CNRC

## SPECIFICATIONS

	UP19K-15S-W5	UP19K-30H-W5	UP19K-50L-W5	UP19K-50F-W5	UP19K-50W-W5
<b>MAX AVERAGE POWER (CONTINUOUS / 1 MINUTE)</b>	15 W / 30 W	30 W / 60 W	50 W / 85 W	50 W / 85 W	50 W <sup>f</sup> / 85 W <sup>f</sup>
<b>EFFECTIVE APERTURE</b>	17 mm Ø	17 mm Ø	17 mm Ø	17 mm Ø	17 mm Ø
<b>COOLING METHOD</b>	Convection	Heatsink	Large Heatsink	Fan-Cooled	Water-Cooled
<b>MEASUREMENT CAPABILITY</b>					
Spectral Range *	0.19 – 10 µm	0.19 – 10 µm	0.19 – 10 µm	0.19 – 10 µm	0.19 – 10 µm
Noise Equivalent Power <sup>a</sup>	1 mW	1 mW	1 mW	1 mW	1 mW
Rise Time (nominal) <sup>b</sup>	1.4 sec	1.4 sec	1.4 sec	1.4 sec	1.4 sec
Sensitivity (typ into 100 kΩ load) <sup>c</sup>	0.65 mV/W	0.65 mV/W	0.65 mV/W	0.65 mV/W	0.65 mV/W
Calibration Uncertainty <sup>d</sup>	±2.5 %	±2.5 %	±2.5 %	±2.5 %	±2.5 %
Repeatability	±0.5 %	±0.5 %	±0.5 %	±0.5 %	±0.5 %
<b>Energy Mode</b>					
Sensitivity	0.33 mV/J	0.33 mV/J	0.33 mV/J	0.33 mV/J	0.33 mV/J
Maximum Measurable Energy <sup>e</sup>	200 J	200 J	200 J	200 J	200 J
Noise Equivalent Energy <sup>a</sup>	0.02 J	0.02 J	0.02 J	0.02 J	0.02 J
Minimum Repetition Period	5 sec	5 sec	5 sec	5 sec	5 sec
Maximum Pulse Width	133 ms	133 ms	133 ms	133 ms	133 ms
Accuracy with energy calibration option	±5 %	±5 %	±5 %	±5 %	±5 %
<b>DAMAGE THRESHOLDS</b>					
Maximum Average Power Density <sup>a</sup>	100 kW/cm <sup>2</sup>	100 kW/cm <sup>2</sup>	100 kW/cm <sup>2</sup>	100 kW/cm <sup>2</sup>	100 kW/cm <sup>2</sup>
Pulsed Laser Damage Thresholds	Max Energy Density		Peak Power Density		
	1064 nm, 150 µs, 10 Hz	100 J/cm <sup>2</sup>	667 kW/cm <sup>2</sup>		
	1064 nm, 7 ns, 10 Hz	1.1 J/cm <sup>2</sup>	157 MW/cm <sup>2</sup>		
	532 nm, 7 ns, 10 Hz	1.1 J/cm <sup>2</sup>	157 MW/cm <sup>2</sup>		
248 nm, 26 ns, 10 Hz	0.7 J/cm <sup>2</sup>	27 MW/cm <sup>2</sup>			
<b>PHYSICAL CHARACTERISTICS</b>					
Effective Aperture	17 mm Ø	17 mm Ø	17 mm Ø	17 mm Ø	17 mm Ø
Absorber (High Damage Threshold)	W5	W5	W5	W5	W5
Dimensions	50H x 50W x 20.6D mm	50H x 50W x 56.3D mm	76.2H x 76.2W x 74.7D mm	54.2H x 54.2W x 55.6D mm	50H x 50W x 33D mm
Weight (head only)	0.16 kg	0.21 kg	0.48 kg	0.25 kg	0.24 kg
<b>ORDERING INFORMATION</b>					
Product Name	UP19K-15S-W5	UP19K-30H-W5	UP19K-50L-W5	UP19K-50F-W5	UP19K-50W-W5
Product Number (Including stand)	200295	200296	200297	200299	200300
Add Extension for INTEGRA	-INT	-INT	-INT	-INT	-INT
Product Number (Including stand)	202632	202634	202636		

Specifications are subject to change without notice

\* For the calibrated spectral range, see the user manual.

- a. Nominal value, actual value depends on electrical noise in the measurement system.  
 b. With Gentec-EO MAESTRO, UNO, P-LINK, TUNER and S-LINK monitors.  
 c. Maximum output voltage = sensitivity x maximum power.  
 d. Including linearity with power.  
 e. For 150 µs pulses. Higher pulse energy possible when customized for long pulses (ms), less for short pulses (ns).  
 f. Minimum cooling flow 1 liters/min, water temperature ≤ 22°C, 1/8 NPT compression fittings for 1/4 inch semi-rigid tube. Contact Gentec-EO for clean deionized water cooling module option.  
 g. At 1064 nm, 10 W CW.



# UP50-W

50 mm Ø, 5 mW – 85 W, 100 kW/cm<sup>2</sup>



## FEATURES

- 1. MODULAR CONCEPT**  
Increase the power capability of your detector:  
4 different cooling modules
- 2. VERY HIGH DAMAGE THRESHOLD**  
100 kW/cm<sup>2</sup> in average power density
- 3. VERY LARGE APERTURE**  
50 mm Ø effective aperture, perfect for the largest beams
- 4. HIGHEST ENERGY READINGS IN THE SERIES**  
Measure single shot energy up to 500 J
- 5. SMART INTERFACE**  
Containing all the calibration data

## AVAILABLE MODELS



UP50N-40S-W9  
(40W-Standalone)



UP50N-50H-W9  
(50W-Heatsink)



UP50N-50F-W9  
(50W-Fan-Cooled)



UP50M-50W-W9  
(50W-Water-Cooled)

## ACCESSORIES



Stand with Steel Post  
(Model Number: 200234)



Extension Cables  
(4, 15, 20 or 25 m)



Fiber Adaptors and Connectors  
(FC, SC or SMA)



3-Port Fiber Cylinder with  
Adaptors and Plug



12V Power Supply  
(Model Number: 200130)



Pelican Carrying Case

## SEE ALSO

HOW IT WORKS	14
CALIBRATION	6
TECHNICAL DRAWINGS	88
ABSORPTION CURVES	92
OEM DETECTORS	134
COMPATIBLE MONITORS	
MAESTRO	20
TUNER	24
UNO	26
S-LINK	28
P-LINK	30
M-LINK	32
LIST OF ALL ACCESSORIES	184
APPLICATION NOTE	
MEASURING LASER POWER WITH A THERMOPILE DETECTOR: THE BASICS!	<a href="#">202175</a>
MEASURING HIGH POWER WITH A LOW POWER DETECTOR	<a href="#">202188</a>

MONITORS

ENERGY DETECTORS

POWER DETECTORS

HIGH POWER SOLUTIONS

PHOTO DETECTORS

THZ DETECTORS

OEM DETECTORS

SPECIAL PRODUCTS

BEAM DIAGNOSTICS

## UP50-W



\*Also traceable to NRC-CNRC

## SPECIFICATIONS

	UP50N-40S-W9	UP50N-50H-W9	UP50N-50F-W9	UP50M-50W-W9
<b>MAX AVERAGE POWER (CONTINUOUS / 1 MINUTE)</b>	40 W / 80 W	50 W / 85 W	50 W / 85 W	50 W <sup>f</sup> / 85 W <sup>f</sup>
<b>EFFECTIVE APERTURE</b>	50 mm Ø	50 mm Ø	50 mm Ø	50 mm Ø
<b>COOLING METHOD</b>	Convection	Heatsink	Fan-Cooled	Water-Cooled
<b>MEASUREMENT CAPABILITY</b>				
Spectral Range *	0.19 – 10 µm	0.19 – 10 µm	0.19 – 10 µm	0.19 – 10 µm
Noise Equivalent Power <sup>a</sup>	5 mW	5 mW	5 mW	5 mW
Rise Time (nominal) <sup>b</sup>	3.5 sec	3.5 sec	3.5 sec	3.5 sec
Sensitivity (typ into 100 kΩ load) <sup>c</sup>	0.12 mV/W	0.12 mV/W	0.12 mV/W	0.12 mV/W
Calibration Uncertainty <sup>d</sup>	±2.5 %	±2.5 %	±2.5 %	±2.5 %
Repeatability	±0.5 %	±0.5 %	±0.5 %	±0.5 %
Energy Mode				
Sensitivity	0.02 mV/J	0.02 mV/J	0.02 mV/J	0.02 mV/J
Maximum Measurable Energy <sup>e</sup>	500 J	500 J	500 J	500 J
Noise Equivalent Energy <sup>a</sup>	0.25 J	0.25 J	0.25 J	0.25 J
Minimum Repetition Period	11.1 sec	11.1 sec	11.1 sec	11.1 sec
Maximum Pulse Width	467 ms	467 ms	467 ms	467 ms
Accuracy with energy calibration option	±5 %	±5 %	±5 %	±5 %
<b>DAMAGE THRESHOLDS</b>				
Maximum Average Power Density <sup>a</sup>	100 kW/cm <sup>2</sup>	100 kW/cm <sup>2</sup>	100 kW/cm <sup>2</sup>	100 kW/cm <sup>2</sup>
Pulsed Laser Damage Thresholds	Max Energy Density		Peak Power Density	
1064 nm, 150 µs, 5 Hz	100 J/cm <sup>2</sup>		667 kW/cm <sup>2</sup>	
1064 nm, 7 ns, 10 Hz	1.1 J/cm <sup>2</sup>		157 MW/cm <sup>2</sup>	
532 nm, 7 ns, 10 Hz	1.1 J/cm <sup>2</sup>		157 MW/cm <sup>2</sup>	
248 nm, 26 ns, 10 Hz	0.7 J/cm <sup>2</sup>		27 MW/cm <sup>2</sup>	
<b>PHYSICAL CHARACTERISTICS</b>				
Effective Aperture	50 mm Ø	50 mm Ø	50 mm Ø	50 mm Ø
Absorber (High Damage Threshold)	W9	W9	W9	W9
Dimensions	89H x 89W x 32D mm	89H x 89W x 106D mm	89H x 89W x 116D mm	89H x 89W x 40D mm
Weight (head only)	0.62 g	0.93 g	1.38 g	0.81 g
<b>ORDERING INFORMATION</b>				
Product Name	UP50N-40S-W9	UP50N-50H-W9	UP50N-50F-W9	UP50M-50W-W9
Product Number (Including stand)	200896	200897	200898	201887
Add Extension for INTEGRA	-INT	-INT	-INT	-INT

Specifications are subject to change without notice

\* For the calibrated spectral range, see the user manual.

- a. Nominal value, actual value depends on electrical noise in the measurement system.  
 b. With Gentec-EO MAESTRO, UNO, P-LINK, TUNER and S-LINK monitors.  
 c. Maximum output voltage = sensitivity x maximum power.  
 d. Including linearity with power.  
 e. For 360 µs pulses. Higher pulse energy possible when customized for long pulses (ms), less for short pulses (ns).  
 f. Minimum cooling flow 0.5 liters/min, water temperature ≤ 22°C, 1/8 NPT compression fittings for 1/4 inch semi-rigid tube. Contact Gentec-EO for clean deionized water cooling module option.  
 g. At 1064 nm, 10 W CW.



# UP19-VR

18 mm Ø, 2 mW - 35 W, Volume Absorber



## KEY FEATURES

1. **MODULAR CONCEPT**  
Increase the power capability of your detector: 2 different cooling modules
2. **HIGH PEAK POWER VOLUME ABSORBER**
  - Perfect for high density beams
  - Average power density of 700 W/cm<sup>2</sup> prevents degradation caused by repetitive pulses
3. **COMPACT DESIGN**  
Only 21 mm thick (15S model)
4. **ENERGY MODE**  
Measure single shot energy up to 40 J
5. **SMART INTERFACE**  
Containing all the calibration data

## AVAILABLE MODELS



UP19K-15S-VR  
(15W-Standalone)



UP19K-30H-VR  
(30W-Heatsink)

## ACCESSORIES



Stand with Steel Post  
(Model Number: 200160)



Extension Cables  
(4, 15, 20 or 25 m)



Pelican Carrying Case

## SEE ALSO

HOW IT WORKS	<b>14</b>
CALIBRATION	<b>6</b>
TECHNICAL DRAWINGS	<b>88</b>
ABSORPTION CURVES	<b>92</b>
COMPATIBLE MONITORS	
MAESTRO	<b>20</b>
TUNER	<b>24</b>
UNO	<b>26</b>
S-LINK	<b>28</b>
P-LINK	<b>30</b>
M-LINK	<b>32</b>
LIST OF ALL ACCESSORIES	<b>184</b>

## APPLICATION NOTE

MEASURING LASER POWER WITH A THERMOPILE DETECTOR: THE BASICS! [202175](#)

MONITORS

ENERGY DETECTORS

POWER DETECTORS

HIGH POWER SOLUTIONS

PHOTO DETECTORS

THZ DETECTORS

OEM DETECTORS

SPECIAL PRODUCTS

BEAM DIAGNOSTICS

## UP19-VR



\*Also traceable to NRC-CNRC

## SPECIFICATIONS

	UP19K-15S-VR	UP19K-30H-VR
<b>MAX AVERAGE POWER (CONTINUOUS / 1 MINUTE)</b>	15 W / 20 W	30 W / 35 W
<b>EFFECTIVE APERTURE</b>	18 mm Ø	18 mm Ø
<b>COOLING METHOD</b>	Convection	Heatsink
<b>MEASUREMENT CAPABILITY</b>		
Spectral Range <sup>*a</sup>	0.3 – 2.5 µm	0.3 – 2.5 µm
Noise Equivalent Power <sup>b</sup>	2 mW	2 mW
Rise Time (nominal) <sup>c</sup>	2.5 sec	2.5 sec
Sensitivity (typ into 100 kΩ load) <sup>d</sup>	0.34 mV/W	0.34 mV/W
Calibration Uncertainty <sup>e</sup>	±2.5 %	±2.5 %
Repeatability	±0.5 %	±0.5 %
Energy Mode		
Sensitivity	0.1 mV/J	0.1 mV/J
Maximum Measurable Energy <sup>f</sup>	40 J	40 J
Noise Equivalent Energy <sup>b</sup>	0.02 J	0.02 J
Minimum Repetition Period	4.5 sec	4.5 sec
Maximum Pulse Width	90 ms	90 ms
Accuracy with energy calibration option	±5 %	±5 %
<b>DAMAGE THRESHOLDS</b>		
Maximum Average Power Density <sup>g</sup>	700 W/cm <sup>2</sup>	700 W/cm <sup>2</sup>
Pulsed Laser Damage Thresholds	Max Energy Density	Peak Power Density
1064 nm, 360 µs, 10 Hz	40 J/cm <sup>2</sup>	111 kW/cm <sup>2</sup>
1064 nm, 7 ns, 10 Hz	6 J/cm <sup>2</sup>	860 MW/cm <sup>2</sup>
532 nm, 7 ns, 10 Hz	4 J/cm <sup>2</sup>	570 MW/cm <sup>2</sup>
266 nm, 7 ns, 10 Hz	1 J/cm <sup>2</sup>	143 MW/cm <sup>2</sup>
<b>PHYSICAL CHARACTERISTICS</b>		
Effective Aperture	18 mm Ø	18 mm Ø
Absorber (Volume Absorber)	VR	VR
Dimensions	50H x 50W x 20.6D mm	50H x 50W x 56.3D mm
Weight (head only)	0.16 kg	0.21 kg
<b>ORDERING INFORMATION</b>		
Product Name	UP19K-15S-VR	UP19K-30H-VR
Product Number (Including stand)	201149	201150
Add Extension for INTEGRA	-INT	-INT
Product Number (Including stand)	202638	202640

Specifications are subject to change without notice

\* For the calibrated spectral range, see the user manual.

a. Adjustment multipliers for wavelengths under 300 nm are not traceable.

b. Nominal value, actual value depends on electrical noise in the measurement system.

c. With Gentec-EO MAESTRO, UNO, P-LINK, TUNER and S-LINK monitors.

d. Maximum output voltage = sensitivity x maximum power.

e. Including linearity with power.

f. For 360 µs pulses. Higher pulse energy possible when customized for long pulses (ms), less for short pulses (ns).

g. At 1064 nm, 10 W CW.



# UP55-VR

55 mm Ø, 15 mW - 200 W, Volume Absorber



## FEATURES

1. **MODULAR CONCEPT**  
Increase the power capability of your detector:  
4 different cooling modules
2. **HIGH PEAK POWER VOLUME ABSORBER**
  - Perfect for high density beams
  - Average power density of 700 W/cm<sup>2</sup> prevents degradation caused by repetitive pulses
3. **LARGE APERTURE**  
55 mm Ø aperture accomodates the largest beams
4. **HIGH AVERAGE POWER**  
Up to 200 W of continuous power with the water-cooled unit
5. **ENERGY MODE**  
Measure single shot energy up to 200 J
6. **SMART INTERFACE**  
Containing all the calibration data

## AVAILABLE MODELS



UP55N-50S-VR  
(50W-Standalone)



UP55N-100H-VR  
(100W-Heatsink)



UP55N-150F-VR  
(150W-Fan-Cooled)



UP55M-200W-VR  
(200W-Water-Cooled)

## ACCESSORIES



Additional 9V Power Supply  
(Model Number: 200960)



Extension Cables  
(4, 15, 20 or 25 m)



Fiber Adaptors and Connectors  
(FC, SC or SMA)



3-Port Fiber Cylinder with  
Adaptors and Plug



12V Power Supply  
(Model Number: 200130)



Pelican Carrying Case

## SEE ALSO

HOW IT WORKS	14
CALIBRATION	6
TECHNICAL DRAWINGS	88
ABSORPTION CURVES	92
COMPATIBLE MONITORS	
MAESTRO	20
TUNER	24
UNO	26
S-LINK	28
P-LINK	30
M-LINK	32
LIST OF ALL ACCESSORIES	184

**APPLICATION NOTE**  
MEASURING LASER POWER WITH A THERMOPILE DETECTOR: THE BASICS! [202175](#)

MONITORS

ENERGY DETECTORS

POWER DETECTORS

HIGH POWER SOLUTIONS

PHOTO DETECTORS

THZ DETECTORS

OEM DETECTORS

SPECIAL PRODUCTS

BEAM DIAGNOSTICS

## UP55-VR



\*Also traceable to NRC-CNRC

## SPECIFICATIONS

	UP55N-50S-VR	UP55N-100H-VR	UP55N-150F-VR	UP55M-200W-VR
<b>MAX AVERAGE POWER (CONTINUOUS / 1 MINUTE)</b>	50 W / 50 W	100 W / 100 W	150 W / 150 W	200 W <sup>g</sup> / 200 W <sup>g</sup>
<b>EFFECTIVE APERTURE</b>	55 mm Ø	55 mm Ø	55 mm Ø	55 mm Ø
<b>COOLING METHOD</b>	Convection	Heatsink	Fan-Cooled	Water-Cooled
<b>MEASUREMENT CAPABILITY</b>				
Spectral Range <sup>*a</sup>	0.3 – 2.5 µm	0.3 – 2.5 µm	0.3 – 2.5 µm	0.3 – 2.5 µm
Noise Equivalent Power <sup>b</sup>	15 mW	15 mW	15 mW	15 mW
Rise Time (nominal) <sup>c</sup>	4 sec	4 sec	4 sec	4 sec
Sensitivity (typ into 100 kΩ load) <sup>d</sup>	0.04 mV/W	0.04 mV/W	0.04 mV/W	0.04 mV/W
Calibration Uncertainty <sup>e</sup>	±2.5 %	±2.5 %	±2.5 %	±2.5 %
Repeatability	±0.5 %	±0.5 %	±0.5 %	±0.5 %
<b>Energy Mode</b>				
Sensitivity	0.010 mV/J	0.010 mV/J	0.010 mV/J	0.010 mV/J
Maximum Measurable Energy <sup>f</sup>	500 J	500 J	500 J	500 J
Noise Equivalent Energy <sup>b</sup>	0.25 J	0.25 J	0.25 J	0.25 J
Minimum Repetition Period	11.1 sec	11.1 sec	11.1 sec	11.1 sec
Maximum Pulse Width	433 ms	433 ms	433 ms	433 ms
Accuracy with energy calibration option	±5 %	±5 %	±5 %	±5 %
<b>DAMAGE THRESHOLDS</b>				
Maximum Average Power Density <sup>h</sup>	700 W/cm <sup>2</sup>	700 W/cm <sup>2</sup>	700 W/cm <sup>2</sup>	700 W/cm <sup>2</sup>
Pulsed Laser Damage Thresholds	Max Energy Density		Peak Power Density	
	1064 nm, 360 µs, 5 Hz	40 J/cm <sup>2</sup>	111 kW/cm <sup>2</sup>	
	1064 nm, 7 ns, 10 Hz	6 J/cm <sup>2</sup>	860 MW/cm <sup>2</sup>	
	532 nm, 7 ns, 10 Hz	4 J/cm <sup>2</sup>	570 MW/cm <sup>2</sup>	
266 nm, 7 ns, 10 Hz	1 J/cm <sup>2</sup>	143 MW/cm <sup>2</sup>		
<b>PHYSICAL CHARACTERISTICS</b>				
Effective Aperture	55 mm Ø	55 mm Ø	55 mm Ø	55 mm Ø
Absorber (Volume Absorber)	VR	VR	VR	VR
Dimensions	89H x 89W x 32D mm	89H x 89W x 106D mm	89H x 89W x 116D mm	89H x 89W x 44D mm
Weight (head only)	0.62 kg	0.93 kg	1.41 kg	0.84 kg
<b>ORDERING INFORMATION</b>				
Product Name	UP55N-50S-VR	UP55N-100H-VR	UP55N-150F-VR	UP55M-200W-VR
Product Number (Including stand)	201296	201934	201856	201292
Add Extension for INTEGRA	-INT	-INT	-INT	-INT
Product Number (Including stand)	202642	202644		

Specifications are subject to change without notice

\* For the calibrated spectral range, see the user manual.

- Adjustment multipliers for wavelengths under 300 nm are not traceable.
- Nominal value, actual value depends on electrical noise in the measurement system.
- With Gentec-EO MAESTRO, UNO, P-LINK, TUNER and S-LINK monitors.
- Maximum output voltage = sensitivity x maximum power.
- Including linearity with power.
- For 360 µs pulses. Higher pulse energy possible when customized for long pulses (ms), less for short pulses (ns).
- Minimum cooling flow 1 liters/min, water temperature ≤ 22°C, 1/8 NPT compression fittings for 1/4 inch semi-rigid tube. Contact Gentec-EO for clean deionized water cooling module option.
- At 1064 nm, 10 W CW.

# PRONTO-250

1 W - 250 W Power Probe with Touch Screen Controls



## KEY FEATURES

- POCKET-SIZE**  
This mid to high power laser probe is so compact it fits in your pocket!
- EASY-TO-USE**  
The touch screen color LCD allows for a friendly user interface. You can make a measurement with just the touch of a button!
- USER SETTABLE**  
You can set the wavelength, brightness and screen orientation to adapt to your application
- DATA LOGGING**  
Save your data to the internal memory and then transfer it to your PC over the USB connection.
- FROM LOW TO HIGH POWERS**  
Thanks to a low noise level and high damage threshold, the Pronto can measure powers from 1 W to 250 W
- YAG OR CO2 CALIBRATION**  
2 models available:
  - Pronto-250: Calibrated at every wavelength between 248 nm and 2.5  $\mu\text{m}$ , with a typical value at 10.6  $\mu\text{m}$
  - Pronto-250-CO<sub>2</sub>: Calibrated at 10.6  $\mu\text{m}$
- HANDS-FREE OPERATION**  
Place it on a flat surface or use one of the 2 threaded holes that we have integrated in the casing for safe use with optical stands.

## USER INTERFACE

## HANDS-FREE

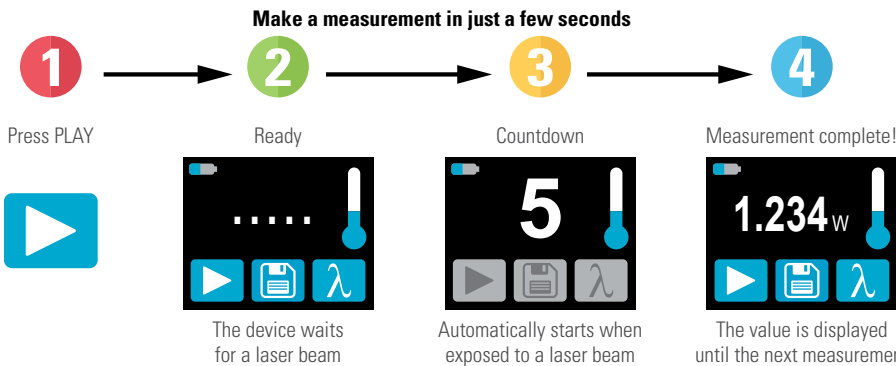

## DATA TRANSFER TO PC



### Adjust the Wavelength and Calibration

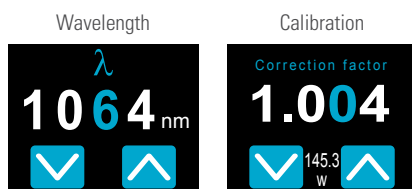

### Warns you when the device is too hot\*



### Set the Brightness and Orientation

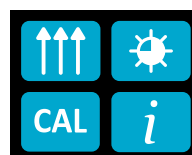

\* Device may get hot, it is not recommended for handheld use when making a measurement

# PRONTO-250

## SPECIFICATIONS

	PRONTO-250	PRONTO-250-CO <sub>2</sub>
<b>MAX AVERAGE POWER</b>	250 W	
<b>EFFECTIVE APERTURE</b>	19 mm Ø	
<b>INTERFACE</b>	Touch Screen Color LCD Display	
<b>MEASUREMENT CAPABILITY</b>		
Spectral Range	0.19 - 20 µm	
Calibrated Spectral Range	0.248 – 2.5 µm <sup>a</sup>	10.6 µm
Noise Equivalent Power	10 mW	
Response Time	5 sec	
Measurement Accuracy	± 3 %	
Display Resolution	1 mW	
<b>DAMAGE THRESHOLDS</b>		
Maximum Average Power Density <sup>b</sup>	45 kW/cm <sup>2</sup>	
Maximum Exposure Time	5 sec	
Maximum Device Temperature	65°C	
<b>USER INTERFACE</b>		
Measurement Controls	Wavelength Selection and User Calibration	
Data Acquisition and Transfer	Simple On/Off Controls, saves to on-board memory and transfers data to the PC using the USB connection	
Screen Personalization	Orientation and Brightness controls	
Battery Indicator	On-screen indicator with 4 levels	
<b>GENERAL SPECIFICATIONS</b>		
Display Type	Touch Screen Color LCD	
Display Size	28.0 x 35.0 mm (128 x 160 pixels)	
Backlight	Adjustable	
Internet Upgrades Via	USB port	
Battery Type	Rechargeable Li-ion	
Battery Life	17 hours or 4 200 measurements (with brightness set at 25%)	
Battery Recharge Via	USB port	
Operating Temperature Range	15 - 28 °C (max 80% RH)	
<b>PHYSICAL CHARACTERISTICS</b>		
Effective Aperture	19 mm Ø	
Absorber	H9	
Mounting Holes (for Post)	2 x 8-32	
Dimensions	41.0W x 181.4L x 17.0D	
Weight	210 g	
<b>ORDERING INFORMATION</b>		
Product Name	PRONTO-250	PRONTO-250-CO <sub>2</sub>
Product Number	202917	202992

Specifications are subject to change without notice

a. With typical value at 10.6 µm

b. At 1064 nm, 10 W, CW.

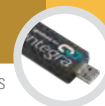

# UM-B

5 nW - 25 mW, Radiometer for Ultra-Low Power Measurements



## KEY FEATURES

1. **VERY LOW NOISE LEVEL**  
Noise levels of a photo detector, but with the large bandwidth of a pyroelectric:
  - Down to 5 nW when using the Analog Power Module (APM)
2. **VERY HIGH RESPONSIVITY**  
Up to 20 000 V/W when using the Analog Power Module (APM)
3. **VERY LARGE BANDWIDTH**  
From DUV to FIR thanks to pyroelectric technology
4. **SMART INTERFACE**  
Containing all the calibration data

## AVAILABLE MODELS



UM9B-BL  
(9 mm-Organic Black)

## ACCESSORIES



Stand with Delrin Post  
(Model Number: 200428)



Fiber Adaptors & Connectors  
(FC, ST or SMA)



APM Analog Power Supply  
(Model Number: 201848)

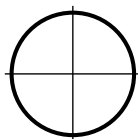

IR Alignment Aide  
and Crosshairs



SDC-500 Digital  
Optical Chopper

## SEE ALSO

TECHNICAL DRAWINGS	<b>88</b>
COMPATIBLE MONITORS	
MAESTRO	<b>20</b>
M-LINK	<b>32</b>
LIST OF ALL ACCESSORIES	<b>184</b>

## APPLICATION NOTE

SDC-500 DIGITAL OPTICAL CHOPPER [202154](#)

MONITORS

ENERGY DETECTORS

POWER DETECTORS

HIGH POWER SOLUTIONS

PHOTO DETECTORS

THZ DETECTORS

OEM DETECTORS

SPECIAL PRODUCTS

BEAM DIAGNOSTICS

## UM-B



\*Also traceable to NRC-CNRC

## SPECIFICATIONS

## UM9B-BL

<b>MAX AVERAGE POWER</b>	25 mW
<b>EFFECTIVE APERTURE</b>	9 mm Ø
<b>COMPATIBLE MONITORS</b>	APM and Power Monitors

<b>MEASUREMENT CAPABILITY</b>	With APM	With Monitor
Spectral Range *	0.1 - 20 µm	0.1 - 20 µm
Maximum Measurable Power	40 mW	20 mW (MAESTRO), 25 mW (M-LINK)
Noise Equivalent Power (RMS)	5 nW	300 nW
Rise Time (0-100%)	≤ 0.2s	≤ 0.2s
Sensitivity	20 000 V/W	120 V/W
Calibration Uncertainty	±4 % @ 1064 nm	±4 % @ 1064 nm
Chopper Frequency <sup>a</sup>	10 ± 1 Hz	10 ± 1 Hz
Maximum Average Power Density (1064 nm)	50 mW/cm <sup>2</sup>	50 mW/cm <sup>2</sup>

**PHYSICAL CHARACTERISTICS**

Effective Aperture	9 mm Ø
Absorber	Organic Black
Dimensions	38.1Ø X 26.2D mm
Weight	91 g

<b>ORDERING INFORMATION</b>	With APM	With Monitor
Product Name	UM9B-BL-L-D0	UM9B-BL-D0
Product Number (Including stand)	202241	202024
 Add Extension for INTEGRA		-INT

Specifications are subject to change without notice

\* For the calibrated spectral range, see the user manual.

a. SDC-500 Digital Optical Chopper sold separately.

# FLASH-IPL

Handheld Laser Probe for IPL Sources, 2 - 350 J per pulse



## KEY FEATURES

1. **HIGH ENERGY PER PULSE**  
Accurate readings up to 350 J/pulse!
2. **EASY OPERATION**
  - Backlight with ON/OFF controls
  - Thermometer for head temperature
  - Red and Green LEDs for device status
  - Functions separated on 2 buttons
3. **AVAILABLE WITH HANDLE OR CABLE**
  - Standard Model: Fixed Handle
  - In Option: -C Model with 5 feet soft cable and removable handle
4. **LARGE APERTURE**  
55 mm  $\varnothing$  aperture to accommodate large beams
5. **RUGGED**
  - All-metal body
  - High Damage Thresholds
6. **QUARTZ WINDOW**
  - For measurements with gel-coupled IPL heads.
  - Protects the absorber, easy to clean

## AVAILABLE MODELS



FLASH-500-55-W-IPL  
(55 mm  $\varnothing$  with Window)



FLASH-500-55-W-IPL-C  
(55 mm  $\varnothing$  Win. & Cable)

## ACCESSORIES



Stand with Steel Post  
(Model Number: 201102)



Pelican Carrying Case

## SEE ALSO

HOW IT WORKS	14
CALIBRATION	6
TECHNICAL DRAWINGS	88
ABSORPTION CURVES	92
LIST OF ALL ACCESSORIES	184

## FLASH-IPL



\*Also traceable to NRC-CNRC

## SPECIFICATIONS

## FLASH-500-55-W-IPL

<b>MAX PULSE ENERGY (SINGLE SHOT)</b>	350 J
<b>EFFECTIVE APERTURE</b>	55 mm Ø
<b>APERTURE TYPE</b>	Full Aperture with Quartz Window

## MEASUREMENT CAPABILITY

Spectral Range	0.19 - 2.5 µm
Available Wavelengths	YAG, Custom (250 - 2000 nm)
Wavelengths per unit	Up to 3 Calibrations/Unit
IPL Mode (Energy Mode)	
Energy Range	2 - 350 J
Noise Equivalent Energy	500 mJ
Sensitivity	0.013 mV/J
Response Time	2 sec
Minimum Repetition Period	15 sec (= time between measurements)
Maximum Pulse Width	433 ms
Accuracy in IPL Mode	±5 %
Power Mode	
Maximum Measurable Power	500 W
Noise Equivalent Power	0.1 W
Response Time	5 sec
Calibration Uncertainty	Typical Value (±3 % uncertainty available with optional power mode calibration)

## DAMAGE THRESHOLDS

Maximum Average Power Density	45 kW/cm <sup>2</sup> (1064 nm, 10 W, CW)
Pulsed Laser Damage Threshold	175 J/cm <sup>2</sup> (10 ms pulses)
Maximum Allowable Absorber Temperature	65 °C

## GENERAL SPECIFICATIONS

Digital Display	40 x 20 mm
Battery Type	2 x AA batteries, 3.0 V
Battery Life	>5000 measurements
Operating/Storage Temperature Range	10 to 40 °C / 10 to 60 °C

## PHYSICAL CHARACTERISTICS

Effective Aperture	55 mm Ø
Dimensions (Sensor Head, Monitor and Handle)	335H x 88W x 35D mm
Weight	930 g

## ORDERING INFORMATION

	Standard	Cable
Common Product Name	FLASH-500-55-W-IPL	
Add Extension for Cable		-C
Product Number	202064	202065

Specifications are subject to change without notice

# TECHNICAL DRAWINGS

All dimensions in mm

## XLP12

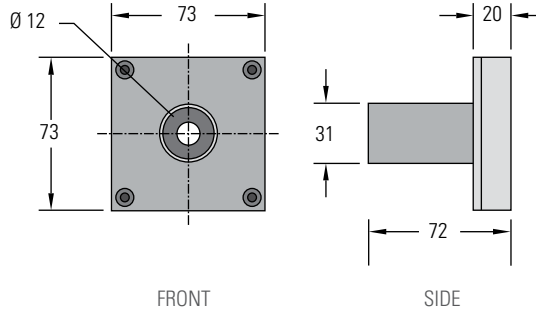

## UP12-H

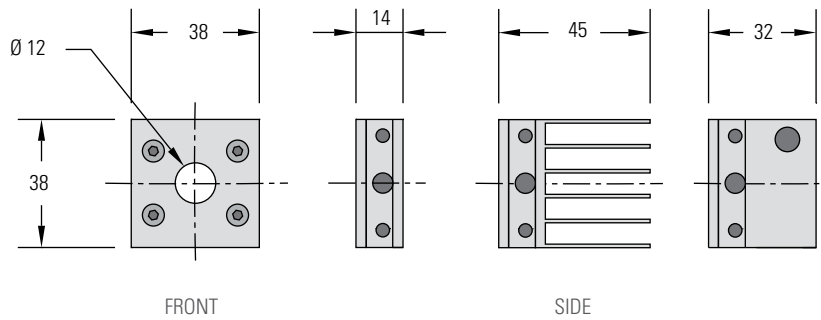

## UP19-H

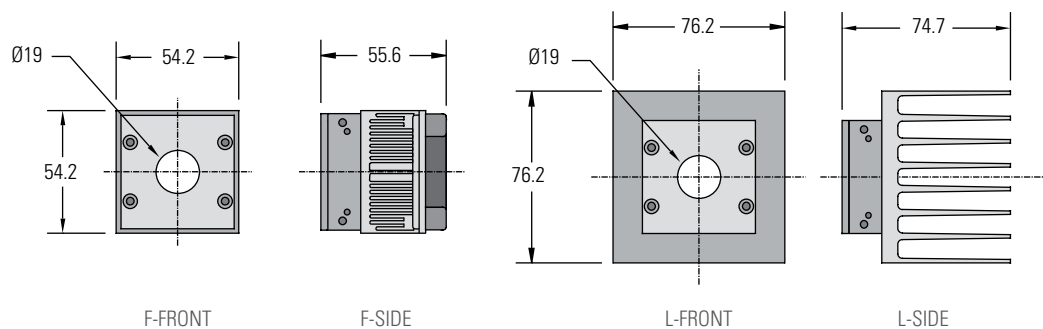
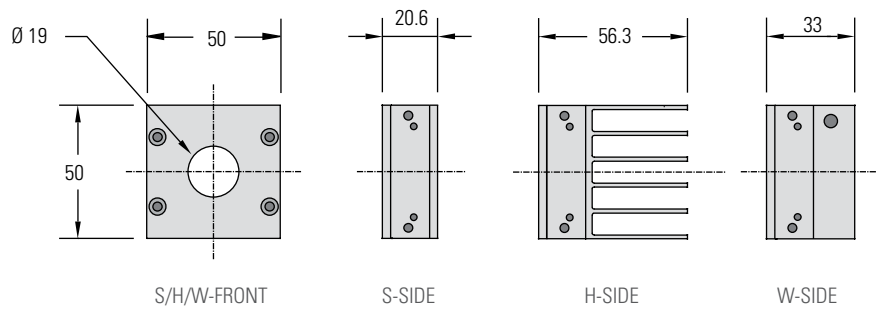

# TECHNICAL DRAWINGS

All dimensions in mm

## UP25N-H

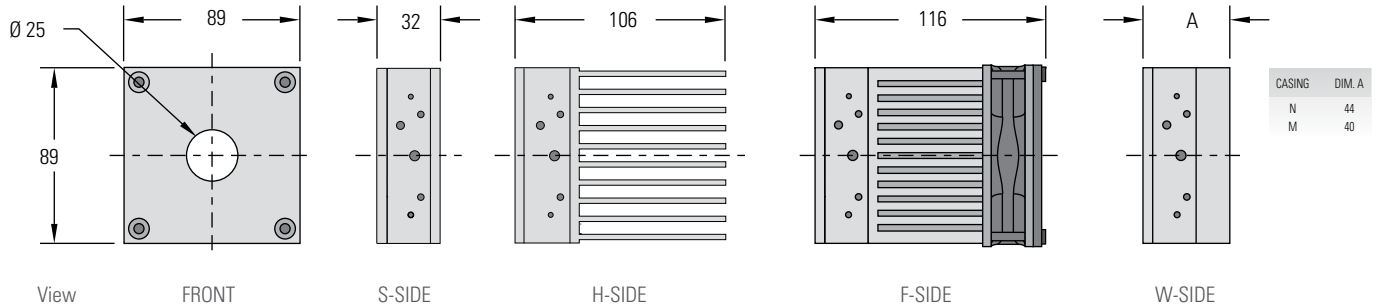

## UP55-H

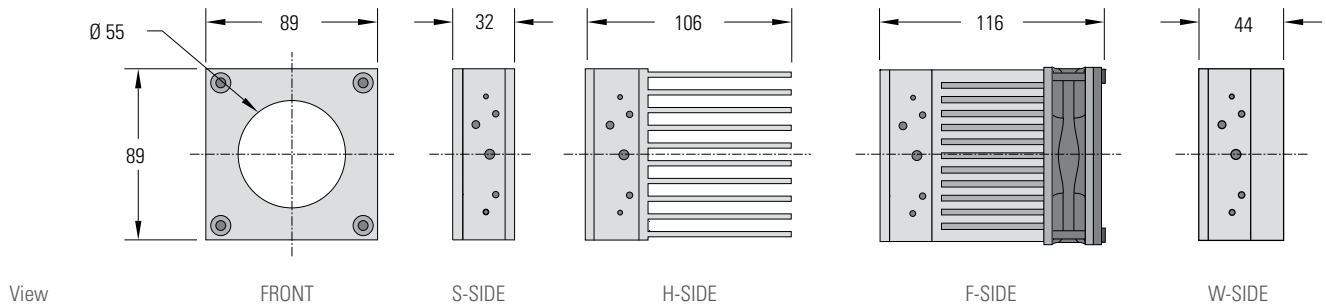

## UP17-H/W

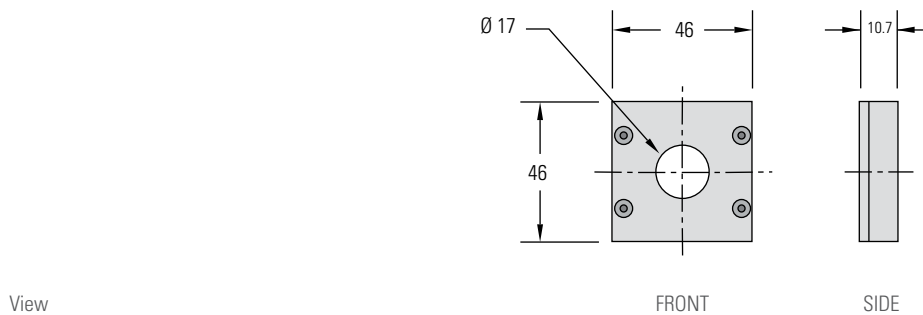

# TECHNICAL DRAWINGS

All dimensions in mm

## UP19-W

MONITORS

ENERGY DETECTORS

POWER DETECTORS

HIGH POWER SOLUTIONS

PHOTO DETECTORS

THZ DETECTORS

OEM DETECTORS

SPECIAL PRODUCTS

BEAM DIAGNOSTICS

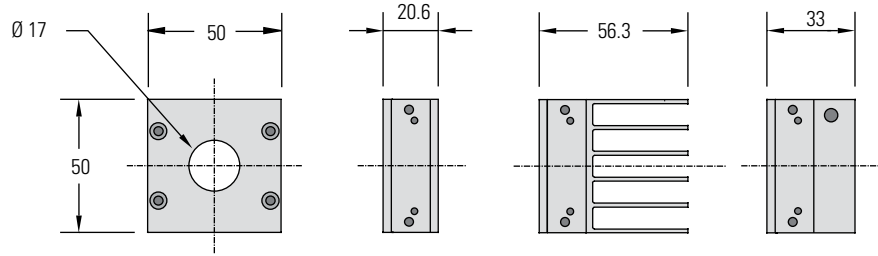

View

S/H/W-FRONT

S-SIDE

H-SIDE

W-SIDE

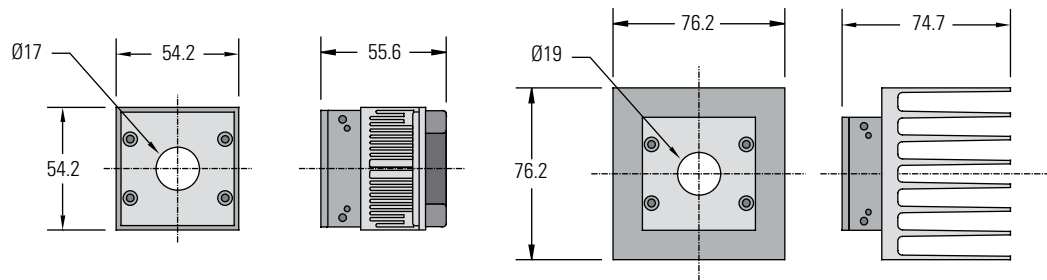

View

F-FRONT

F-SIDE

L-FRONT

L-SIDE

## UP50-W

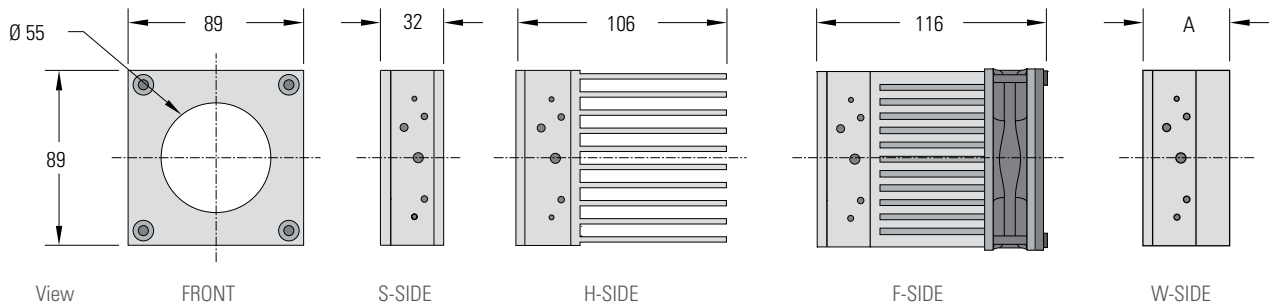

CASING	DIM. A
N	44
M	40

View

FRONT

S-SIDE

H-SIDE

F-SIDE

W-SIDE

## UP19-VR

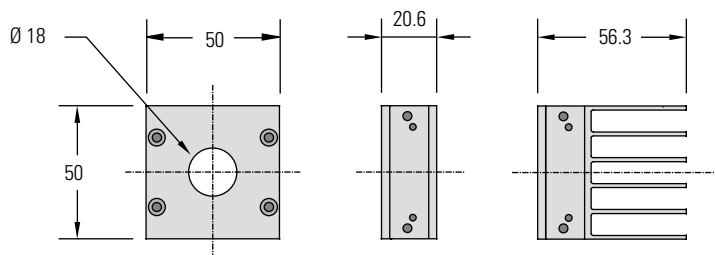

View

FRONT

S-SIDE

H-SIDE

# TECHNICAL DRAWINGS

All dimensions in mm

## UP55-VR

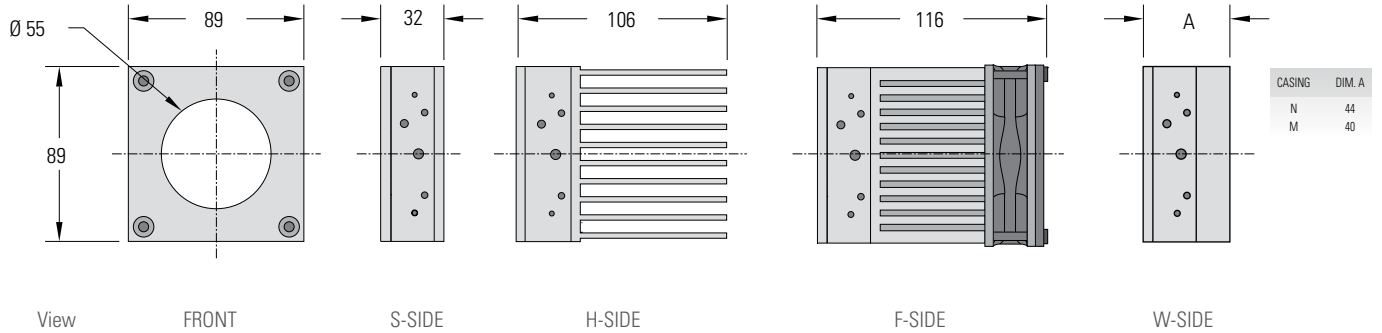

## PRONTO-250

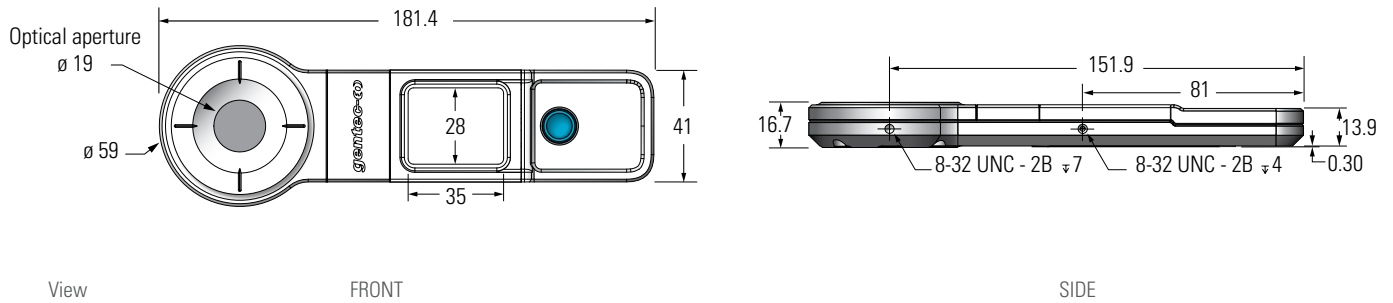

## UM-B

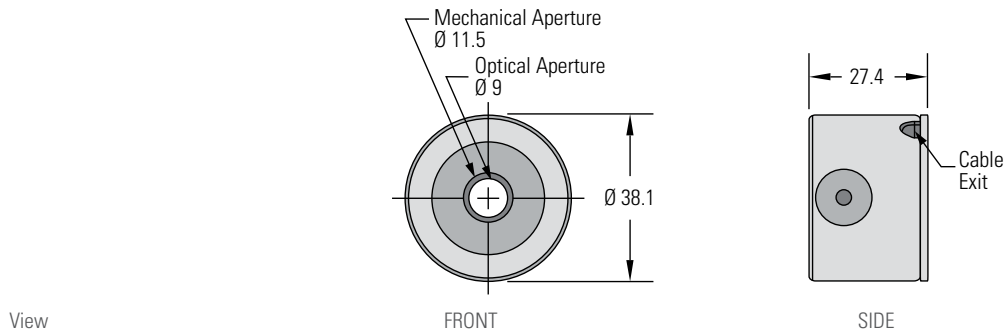

## FLASH-500-55-W-IPL

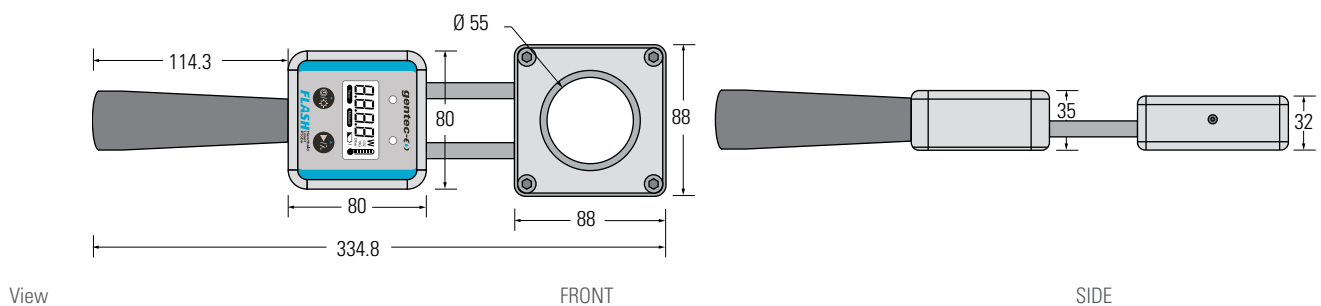

# ABSORPTION CURVES

XLP12-H , UP-H & FLASH-IPL

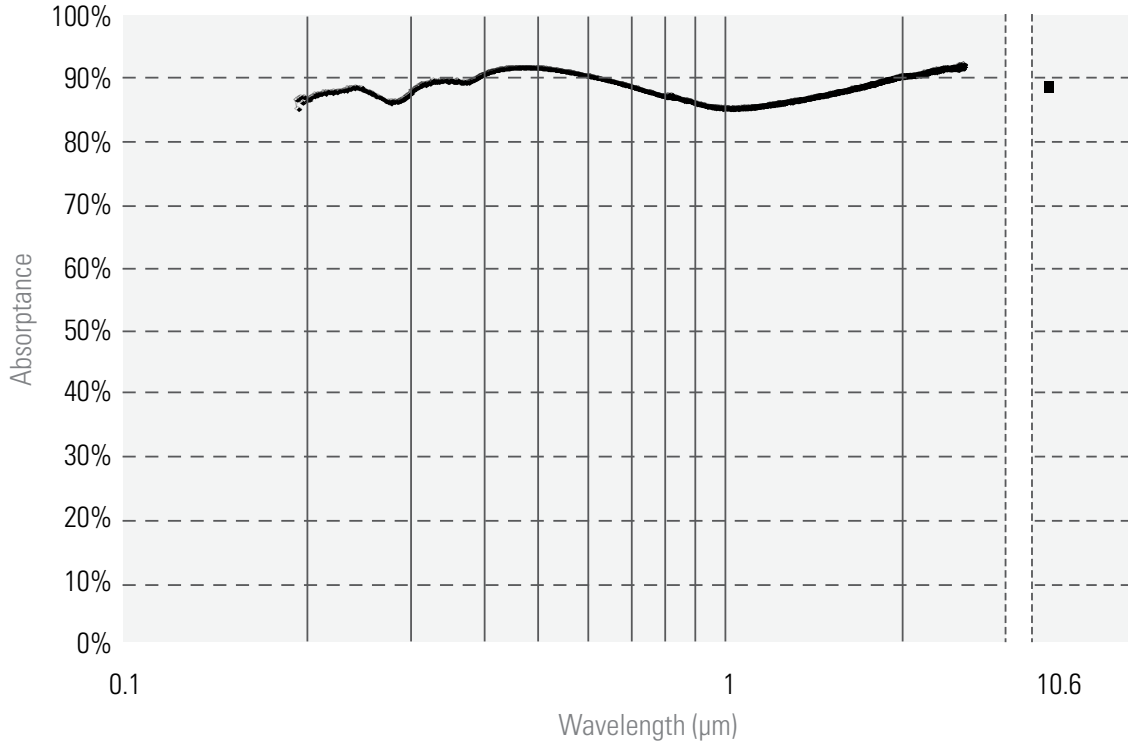

XLP12-VP

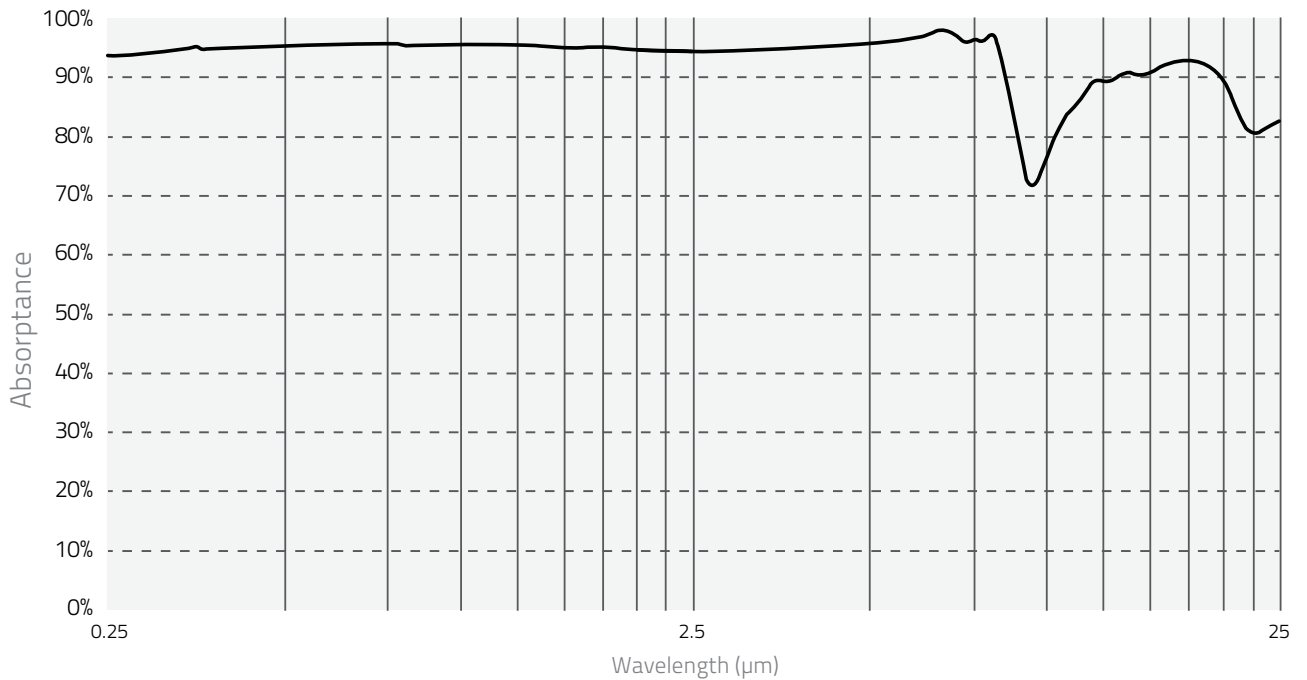

- MONITORS
- ENERGY DETECTORS
- POWER DETECTORS
- HIGH-POWER SOLUTIONS
- PHOTO DETECTORS
- THZ DETECTORS
- OEM DETECTORS
- SPECIAL PRODUCTS
- BEAM DIAGNOSTICS

# ABSORPTION CURVES

## UP-W



## UP-VR

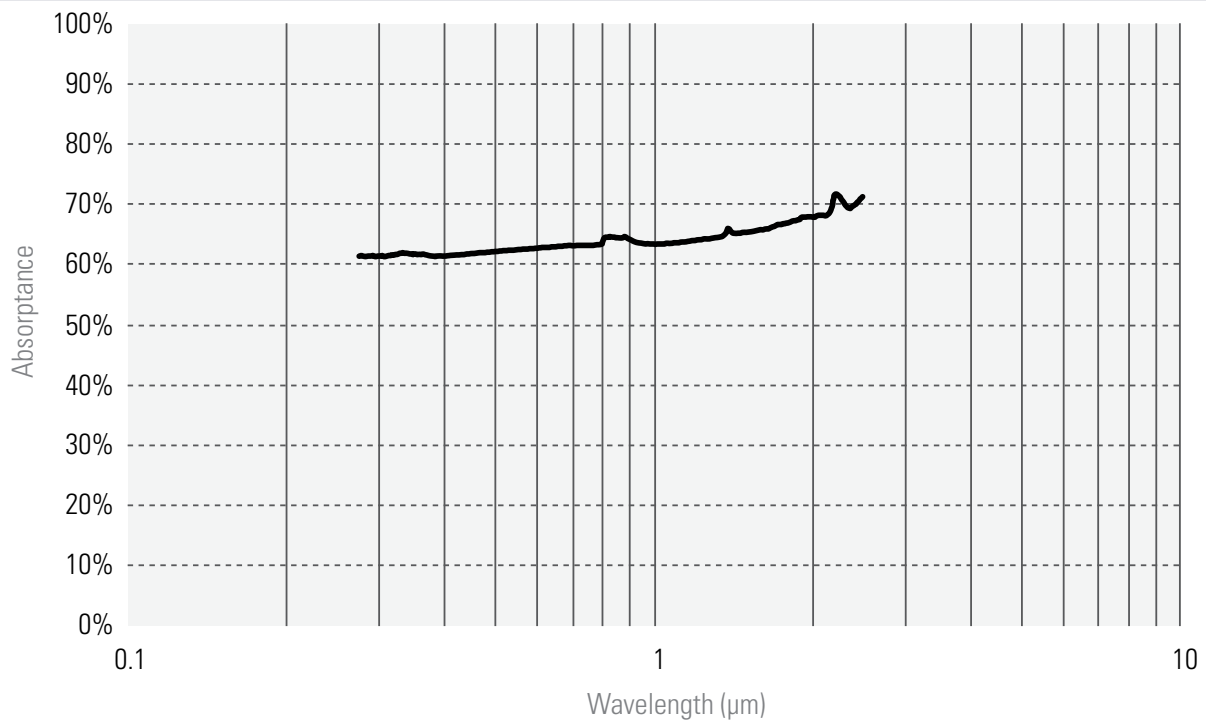

# PRESENTATION

## 600 W FAN-COOLED



- Noise: 45 mW
- Max Power: 600 W
- Aperture: 55 mm Ø
- Cooling: 



### UP55G-600F-HD

Unique on the market, the UP55G-600F-HD measures 600 W of continuous power WITHOUT THE NEED FOR WATER-COOLING. Just plug the fan and you are ready to go! This detector is the ideal choice for service technicians that wish to cut down on the setup times at each customer visit.

Available with  
  
*integra*

## 700 W COMPACT SIZE



- Noise: 45 mW
- Max Power: 700 W
- Aperture: 55 mm Ø
- Cooling: 



### UP55M-700W-HD

The UP55M-700W-HD is a very compact detector that measures up to 700 W of continuous power. Since it is based on our popular mid-power series UP55-H, it also features a fast response time and low noise level, ensuring quick and accurate measurements from the mW level to several hundreds of Watts.

Available with  
  
*integra*

## 2 500 W WIDE POWER RANGE



- Noise: 200 mW
- Max Power: 2 500 W
- Aperture: 55 mm Ø
- Cooling: 



### UP55C-2.5KW-HD

The UP55C-2.5KW-HD is very in demand because it measures both very low and very high powers (up to 2 500 W), thanks to a noise level of only 200 mW. It also has the fastest response time for a detector of its size. This is a compact and versatile detector that is more affordable than any other high power solution on the market.

Available with  
  
*integra*

## 4 000 W TO 12 000W LARGE APERTURE



- Noise: 3-10 W
- Max Power: 4 000 to 12 000 W
- Aperture: 100 mm Ø
- Cooling: 



### HP100A-4KW-HE & HP100A-12KW-HD

The HP100A are the smallest in our HP Series of high power detectors. They are versatile high power detectors that measure up to 12 kW of continuous power with a noise level of only a few Watts. As all the other HP detectors, those models feature a USB output for direct measurements on a PC and a very large aperture of 100 mm Ø.

# PRESENTATION

## 10 000 W SMALL BEAMS



- Noise: 10 W
- Max Power: 10 000 W
- Aperture: 60 mm Ø
- Cooling: 

 + USB

### HP60A-10KW-GD

The gold reflector cone of the HP60A-10KW-GD is specifically designed to handle the high intensities of very small beams. By reflecting the incident light on the sides of the aperture, the cone effectively spreads the intensity on a larger area, thus raising the damage threshold to 10 kW/cm<sup>2</sup> @ the full power (10 kW). Also features a USB output for direct measurements on a PC.

## 25 000 W AND MORE CUSTOM SHAPES



- Up to 25 000 W
- Up to 400 X 400 mm
- Cooling: 

 + USB

### SUPER HP

Our unique high power design allows for infinite customization capabilities. The square and rectangular apertures shown here are just examples of our capabilities, so do not hesitate to contact us with your specific needs. All our Super HP models feature a USB output for direct measurements on a PC as well as our standard DB-15 connector if you prefer to do the measurement using one of our power monitors.

## 500 W TO 10 000 W HANDHELD PROBES



- Noise: 100 mW
- Max Power: 10 000 W
- Aperture: 55 mm Ø
- Cooling: 

### FLASH

The FLASH Series of Handheld Laser Probes come in 4 models: 500, 3 000, 6 000 and 10 000 W, all in the same compact format that make them highly portable. Their integrated display is encased in a rugged metallic casing to withstand the harshest of environments. All models are available either with a fixed handle or a removable handle with 5 feet of soft cable.

## BEAM DUMPS FOR LASERS UP TO 12 000 W



- Rugged
- Easy-to-Use
- Absorb up to 12 000 W in Continuous Mode
- Large 100 mm Ø Aperture

### BD-4KW-HE & BD-12KW-HD

Our new Beam Dumps are rugged and easy-to-use, simply plug the water-cooling and you're ready to go! Like our high power HP Detectors, these beam dumps have a highly resistant absorber that can withstand several kW in continuous mode. Their very large aperture of 100 mm in diameter accommodates even the largest beams. An isolation tube (available in option) helps reduce the back reflections. 2 models are offered: 4 kW and 12 kW.



# UP55-HD

55 mm Ø, 45 mW - 2 500 W

600 W

2 500 W

700 W



## FEATURES

- HIGH DENSITY ABSORBER**  
The HD absorber is the strongest on the market for use at high powers, presenting both high average power handling and high power density capabilities
- UP55G-600F-HD - NO NEED FOR WATER-COOLING**  
Unique on the market, measure 600 W of continuous power WITHOUT THE NEED FOR WATER-COOLING. Just plug the fan and you are ready to go!
- UP55M-700W-HD - FAST AND COMPACT**  
A very compact detector that measures up to 700 W of continuous power.
- UP55C-2.5KW-HD - PERFORMANCE AND SPEED AT A LOW PRICE**  
Measures both very low and very high powers (up to 2 500W) with a fast response time. A compact and versatile detector that is more affordable than any other high power solution on the market.

## AVAILABLE MODELS



UP55G-600F-H12  
(600W-Fan-Cooled)



UP55M-700W-HD  
(700W-Water-Cooled)



UP55C-2.5KW-HD  
(2500W-Water-Cooled)

## ACCESSORIES



Stand with Steel Post  
(Model Number: 201102)



Extension Cables  
(4, 15, 20 or 25 m)



Fiber Adaptors and Connectors  
(FC, SC or SMA)



3-Port Fiber Cylinder with  
Adaptors and Plug



12V Power Supply  
(Model Number: 200130)



Pelican Carrying Case

## SEE ALSO

HOW IT WORKS	14
CALIBRATION	6
TECHNICAL DRAWINGS	106
COMPATIBLE MONITORS	
MAESTRO	20
TUNER	24
UNO	26
S-LINK	28
P-LINK	30
M-LINK	32
LIST OF ALL ACCESSORIES	184

MONITORS  
ENERGY DETECTORS  
POWER DETECTORS  
HIGH POWER SOLUTIONS  
PHOTO DETECTORS  
THZ DETECTORS  
OEM DETECTORS  
SPECIAL PRODUCTS  
BEAM DIAGNOSTICS

## UP55-HD



\*Also traceable to NRC-CNRC

## SPECIFICATIONS

	UP55G-600F-HD	UP55M-700W-HD	UP55C-2.5KW-HD
<b>MAX AVERAGE POWER (CONTINUOUS / 1 MINUTE)</b>	600 W / 600 W	700 W <sup>1</sup> / 700 W <sup>1</sup>	2 500 W / 2 500 W
<b>EFFECTIVE APERTURE</b>	55 mm Ø	55 mm Ø	55 mm Ø
<b>COOLING METHOD</b>	Fan-Cooled	Water-Cooled	Water-Cooled
<b>MEASUREMENT CAPABILITY</b>			
Spectral Range *	0.19 – 20 µm	0.19 – 20 µm	0.19 – 20 µm
Noise Equivalent Power <sup>a</sup>	45 mW	45 mW	200 mW
Rise Time (nominal) <sup>b</sup>	2.8 sec	2 sec	3.5 sec
Sensitivity (typ into 100 kΩ load) <sup>c</sup>	0.03 mV/W	0.03 mV/W	8 µV/W
Calibration Uncertainty <sup>d</sup>	±2.5 %	±2.5 %	±2.5 %
Repeatability	±0.5 %	±0.5 %	±0.5 %
<b>Energy Mode</b>			
Sensitivity	0.008 mV/J	0.008 mV/J	---
Maximum Measurable Energy <sup>e</sup>	200 J	200 J	---
Noise Equivalent Energy <sup>a</sup>	0.25 J	0.25 J	---
Minimum Repetition Period	12 sec	12 sec	---
Maximum Pulse Width	430 ms	430 ms	---
Accuracy with energy calibration option	±5 %	±5 %	---
<b>DAMAGE THRESHOLDS</b>			
<b>Maximum Average Power Density</b>			
1064 nm, 10 W, CW	45 kW/cm <sup>2</sup>	45 kW/cm <sup>2</sup>	45 kW/cm <sup>2</sup>
1064 nm, 500 W, CW	8 kW/cm <sup>2</sup>	8 kW/cm <sup>2</sup>	9 kW/cm <sup>2</sup>
1064 nm, 2 500 W, CW	---	---	6 kW/cm <sup>2</sup>
<b>Pulsed Laser Damage Thresholds</b>			
	Max Energy Density		Max Power Density
1064 nm, 360 µs, 5 Hz	9 J/cm <sup>2</sup>		25 kW/cm <sup>2</sup>
1064 nm, 7 ns, 10 Hz	1 J/cm <sup>2</sup>		143 MW/cm <sup>2</sup>
532 nm, 7 ns, 10 Hz	0.6 J/cm <sup>2</sup>		86 MW/cm <sup>2</sup>
266 nm, 7 ns, 10 Hz	0.3 J/cm <sup>2</sup>		43 MW/cm <sup>2</sup>
<b>PHYSICAL CHARACTERISTICS</b>			
Effective Aperture	55 mm Ø	55 mm Ø	55 mm Ø
Absorber (High Damage Threshold)	HD	HD	HD
Dimensions	120H x 120W x 135D mm	89H x 89W x 40D mm	116H x 116W x 48D mm
Weight (head only)	2.75 kg	0.90 kg	1.95 kg
<b>ORDERING INFORMATION</b>			
Product Name	UP55G-600F-HD	UP55M-700W-HD	UP55C-2.5KW-HD
Product Number	201879	201916	202219
Add Extension for INTEGRA	-INT	-INT	-INT

Specifications are subject to change without notice

\* For the calibrated spectral range, see the user manual.

a. Nominal value, actual value depends on electrical noise in the measurement system.

b. With Gentec-EO MAESTRO, UNO, P-LINK, TUNER and S-LINK monitors.

c. Maximum output voltage = sensitivity x maximum power.

d. Including linearity with power.

e. For 360 µs pulses. Higher pulse energy possible when customized for long pulses (ms), less for short pulses (ns).

f. Minimum cooling flow 3 liters/min, water temperature ≤22°C, 1/8 NPT compression fittings for 1/4 inch semi-rigid tube.

Contact Gentec-EO for clean deionized water cooling module option.

# HP

Up to 100 mm Ø, 100 W – 12 000 W



## KEY FEATURES

- 1. HIGH POWER HANDLING**  
Handles up to 12 kW of continuous power with our standard models. Custom models available for higher powers (See SUPER HP)
- 2. STABLE READING**  
Less sensitive to variations in water cooling temperature than any other high power water-cooled meter on the market
- 3. LARGE APERTURE**  
Our standard HP models (4kW and 12kW) have a very large effective aperture of 100 mm Ø to accommodate large laser beams. Larger apertures with various shapes are available upon request (See SUPER HP)
- 4. SPECIAL MODEL FOR SMALL BEAMS**  
10 kW model with reflective cone available. Perfect for small beams (with Avg Power Densities up to 10 kW/cm<sup>2</sup> @ 10 kW)
- 5. AVAILABLE WITH YAG AND CO<sub>2</sub> CALIBRATIONS**  
All HP Models can be calibrated at YAG and CO<sub>2</sub> wavelengths with a calibration uncertainty of ± 2.5%
- 6. DIRECT USB CONNECTION TO A PC**  
Each head comes with both a DB-15 connector (for use with a Gentec-EO monitor) and a USB2.0 output for direct connection to a PC

## AVAILABLE MODELS



HP100A-4KW-HE  
(4000W-Water-Cooled)



HP100A-12KW-HD  
(12000W-Water-Cooled)



HP60A-10KW-GD  
(10000W-Small Beams)

## ACCESSORIES



Stand with Steel Post  
(Model Number: 201102)



Extension Cables  
(4, 15, 20 or 25 m)



5 m USB Cable  
(Included)



Pelican Carrying Case

## SEE ALSO

HOW IT WORKS	14
CALIBRATION	6
TECHNICAL DRAWINGS	106
COMPATIBLE MONITORS	
MAESTRO	20
TUNER	24
UNO	26
S-LINK	28
P-LINK	30
M-LINK	32
LIST OF ALL ACCESSORIES	184

MONITORS

ENERGY DETECTORS

POWER DETECTORS

HIGH POWER SOLUTIONS

PHOTO DETECTORS

THZ DETECTORS

OEM DETECTORS

SPECIAL PRODUCTS

BEAM DIAGNOSTICS

HP



\*Also traceable to NRC-CNRC

## SPECIFICATIONS

	HP100A-4KW-HE	HP100A-12KW-HD	HP60A-10KW-GD
<b>MAX AVERAGE POWER (CONTINUOUS / 2 MINUTES)</b>	4 000 W / 4 500 W	12 000 W / 12 000 W	10 000 W / 10 000 W High Average Power up to 10 kW/cm <sup>2</sup>
<b>EFFECTIVE APERTURE</b>	100 mm Ø	100 mm Ø	60 mm Ø with cone reflector
<b>COOLING METHOD</b>	Water-Cooled	Water-Cooled	Water-Cooled
<b>MEASUREMENT CAPABILITY</b>			
Spectral Range	0.19 – 20 µm	0.19 – 20 µm	0.8 – 12 µm
Noise Equivalent Power <sup>a</sup>	±3 W	±10 W	±10 W
Minimum Average Power <sup>b</sup>	100 W	300 W	300 W
Rise Time (nominal)	7 sec	9 sec	11 sec
Sensitivity (typ into 100 kΩ load)	0.4 mV/W	0.15 mV/W	0.2 mV/W
Calibration Uncertainty	±5 % @ 1064 nm	±5 % @ 1064 nm	±5 % @ 1064 nm
Repeatability	±2 %	±2 %	±2 %
Linearity with Power	±1.5 %	±1.5 %	±2 %
Linearity vs Beam Diameter	±1 %	±1 %	< 35 mm Ø: ±0.5 % > 35 mm Ø: ±1.5 %
Linearity vs Beam Position	±1.5 %	±1.5 % <sup>c</sup> / ±3 % <sup>d</sup>	±3 %
<b>DAMAGE THRESHOLDS</b>			
Maximum Average Power Density <sup>e</sup>			
500 W	10 kW/cm <sup>2</sup>	16 kW/cm <sup>2</sup>	---
4 kW	4 kW/cm <sup>2</sup>	---	---
5 kW	---	6.5 kW/cm <sup>2</sup>	---
10 kW	---	3.5 kW/cm <sup>2</sup>	< 35 mm Ø: 10 kW/cm <sup>2</sup> > 35 mm Ø: 3.5 kW/cm <sup>2</sup>
<b>PHYSICAL CHARACTERISTICS</b>			
Effective Aperture	100 mm Ø	100 mm Ø	60 mm Ø (Optimized for 35 mm Ø)
Absorber (High Damage Threshold)	HE	HD	GD (cone reflector)
Required Cooling Flow	(4 - 6) LPM < ±1 LPM/min <sup>f</sup>	(6 - 10) LPM < ±1 LPM/min <sup>f</sup>	(6 - 10) LPM < ±1 LPM/min <sup>f</sup>
Temperature of Cooling Water	(15 - 25) °C < ±3°C/min <sup>f</sup>	(15 - 25) °C < ±3°C/min <sup>f</sup>	(15 - 25) °C < ±3°C/min <sup>f</sup>
Output Connectors	DB-15 cable & USB port	DB-15 cable & USB port	DB-15 cable & USB port
PCB Electrical Supply	Through USB or Gentec-EO monitors	Through USB or Gentec-EO monitors	Through USB or Gentec-EO monitors
Maximum Output Signal	2 V	2 V	2 V
Dimensions	127H x 127W x 74D mm	127H x 127W x 70D mm	127H x 127W x 90D mm
Weight (head only)	1.8 kg	3.3 kg	5 kg
<b>ORDERING INFORMATION</b>			
Product Name	HP100A-4KW-HE	HP100A-12KW-HD	HP60A-10KW-GD
Product Number (including stand)	202208	201329	201306

Specifications are subject to change without notice

- a. Nominal value, actual value depends on electrical noise in the measurement system.  
 b. For lower powers, call your Gentec-EO representative.  
 c. For a beam size of 10% of the aperture area, moved across 40% of the aperture area.  
 d. For a beam size of 20% of the aperture area, moved across 80% of the aperture area.  
 e. At 1064 nm, 1.07-1.08 µm and 10.6 µm.  
 f. > 1 min. Contact Gentec-EO for clean deionized water cooling module option.

# SUPER HP

Custom Sizes and Shapes, up to 100 kW upon request



## AVAILABLE MODELS (CUSTOM BUILT)



HP280/100A-10KW-HD  
(10 kW-Water-Cooled)



HP210A-25KW-HD  
(25 kW-Water-Cooled)

## ACCESSORIES



Stand with Steel Post  
For 25 kW Model



Extension Cables  
(4, 15, 20 or 25 m)



5 m USB Cable  
(Included)



Pelican Carrying Case

## KEY FEATURES

1. **THE HIGHEST POWER HANDLING**  
Custom models handle up to 100 000 W of continuous power. Higher powers are available upon request
2. **STABLE READING**  
Less sensitive to variations in water cooling temperature than any other high power water-cooled meter on the market
3. **INFINITE CUSTOMIZATION CAPABILITIES**
  1. Choose YOUR size
  2. Choose YOUR maximum power
  3. We will customize one just for you!
4. **COMPACT AND LIGHT WEIGHT**  
Lighter and more compact than any other high power detector on the market, thanks to our unique design
5. **AVAILABLE WITH YAG AND CO<sub>2</sub> CALIBRATIONS**  
All HP Models can be calibrated at YAG and CO<sub>2</sub> wavelengths with a calibration uncertainty of ±5%
6. **DIRECT USB CONNECTION TO A PC**  
Each head comes with both a DB-15 connector (for use with a Gentec-E0 monitor) and a USB2.0 output for direct connection to a PC. Other connectors available upon request

## SEE ALSO

HOW IT WORKS	<b>14</b>
CALIBRATION	<b>6</b>
TECHNICAL DRAWINGS	<b>106</b>
COMPATIBLE MONITORS	
MAESTRO	<b>20</b>
TUNER	<b>24</b>
UNO	<b>26</b>
S-LINK	<b>28</b>
P-LINK	<b>30</b>
M-LINK	<b>32</b>
LIST OF ALL ACCESSORIES	<b>184</b>

MONITORS

ENERGY DETECTORS

POWER DETECTORS

HIGH POWER SOLUTIONS

PHOTO DETECTORS

THZ DETECTORS

OEM DETECTORS

SPECIAL PRODUCTS

BEAM DIAGNOSTICS

## SUPER HP



\*Also traceable to NRC-CNRC

## SPECIFICATIONS

	HP280/100A-10KW-HD	HP210A-25KW-HD	CUSTOMIZATION CAPABILITIES
<b>MAX AVERAGE POWER (CONTINUOUS / 5 MINUTES)</b>	10 000 W / 10 000 W	25 000 W / 25 000 W	Up to 100 000 W
<b>EFFECTIVE APERTURE</b>	280 x 100 mm	210 x 210 mm	Up to 400 x 400 mm
<b>COOLING METHOD</b>	Water-Cooled	Water-Cooled	Water-Cooled
<b>MEASUREMENT CAPABILITY</b>			
Spectral Range	0.19 – 20 $\mu\text{m}$	0.19 – 20 $\mu\text{m}$	0.19 – 20 $\mu\text{m}$
Noise Equivalent Power <sup>a</sup>	$\pm 10$ W	$\pm 20$ W	$\leq \pm 30$ W
Minimum Average Power <sup>b</sup>	300 W	500 W	$\leq 600$ W
Rise Time (nominal)	20 sec	25 sec	$\leq 45$ sec
Sensitivity (typ into 100 k $\Omega$ load)	0.2 mV/W	0.08 mV/W	$\geq 0.08$ mV/W
Calibration Uncertainty			
@ 1064 nm		$\pm 5$ %	$\pm 5$ %
@ 0.25- 2.5 $\mu\text{m}$		$\pm 6$ %	$\pm 6$ %
Repeatability		$\pm 2$ %	$\pm 2$ %
Linearity with Power		$\pm 2$ %	$\pm 2$ %
Linearity vs Beam Diameter <sup>c</sup>		$\pm 2$ %	$\pm 2$ %
<b>DAMAGE THRESHOLDS</b>			
Maximum Average Power Density <sup>d</sup>			
10 kW	3.5 kW/cm <sup>2</sup>	3.5 kW/cm <sup>2</sup>	3.5 kW/cm <sup>2</sup>
25 kW	---	0.25 kW/cm <sup>2</sup>	0.25 kW/cm <sup>2</sup>
<b>PHYSICAL CHARACTERISTICS</b>			
Effective Aperture	280 x 100 mm	210 x 210 mm	210 x 210 mm 280 x 280 mm 350 x 350 mm 400 x 400 mm (Rectangular apertures also available upon request)
Absorber (High Damage Threshold)		HD	HE, HD
Required Cooling Flow	(6 - 10) LPM $< \pm 1$ LPM/min <sup>f</sup>	(12 - 15) LPM $< \pm 1$ LPM/min <sup>f</sup>	Adapted to Maximum Power
Temperature of Cooling Water	(15 - 25) °C $< \pm 1$ °C/min <sup>f</sup>	(15 - 25) °C $< \pm 1$ °C/min <sup>f</sup>	(15 - 25) °C $< \pm 1$ °C/min <sup>f</sup>
Output Connectors		DB-15 cable & USB port	DB-15 cable & USB port
PCB Electrical Supply		Through USB or Gentec-E0 monitors	Through USB or Gentec-E0 monitors
Maximum Output Signal		2 V	Analog Output 2V or 12V
Dimensions	152H x 305W x 75D mm	229H x 229W x 80D mm	
Weight (head only)	11 kg	16 kg	
<b>ORDERING INFORMATION</b>			
Product Name	HP280/100A-10KW-HD	HP210A-25KW-HD	Please call for more information on our customization capabilities

Specifications are subject to change without notice

- a. Nominal value, actual value depends on electrical noise in the measurement system.  
 b. For lower powers, call your Gentec-E0 representative.  
 c. For a centered beam with size from 20% to 80% of the total aperture.

- d. At 1064 nm, 1.07-1.08  $\mu\text{m}$  and 10.6  $\mu\text{m}$ .  
 e. Average period > 1 min.  
 f. > 1min

# FLASH

Handheld Laser Probe, 500 W, 3 kW, 6 kW and 10 kW



## KEY FEATURES

1. **WIDE POWER RANGE**  
Very low noise level = wide power range with just one device
2. **NO-WAIT MEASUREMENTS**  
5 seconds measurements allow for very short cooling time (all models except FLASH-3K-55)
3. **EASY OPERATION**
  - Backlight with ON/OFF controls
  - Thermometer for head temperature
  - Red and Green LEDs for device status
  - Functions separated on 2 buttons
4. **AVAILABLE WITH HANDLE OR CABLE**
  - Standard Model: Fixed Handle
  - In Option: -C Model with 5 feet soft cable and removable handle
5. **LARGE APERTURE**  
55 mm Ø aperture to accommodate large beams
6. **RUGGED**
  - All-metal body
  - High Damage Thresholds

## AVAILABLE MODELS



FLASH-500-55  
(500 W-Handheld)

FLASH-3K-55  
(3 kW-Handheld)

FLASH-(6K/10K)-55  
(6 & 10 kW-Handheld)

FLASH-500-55-C  
(500 W-With Cable)

FLASH-3K-55-C  
(3 kW-With Cable)

FLASH-(6K/10K)-55-C  
(6 & 10 kW-With Cable)

## ACCESSORIES



Stand with Steel Post  
(Model Number: 201102)



Pelican Carrying Case

## SEE ALSO

HOW IT WORKS	<b>14</b>
CALIBRATION	<b>6</b>
TECHNICAL DRAWINGS	<b>106</b>
LIST OF ALL ACCESSORIES	<b>184</b>

MONITORS

ENERGY DETECTORS

POWER DETECTORS

HIGH POWER SOLUTIONS

PHOTO DETECTORS

THZ DETECTORS

OEM DETECTORS

SPECIAL PRODUCTS

BEAM DIAGNOSTICS

## FLASH



\*Also traceable to NRC-CNRC

## SPECIFICATIONS

	FLASH-500-55		FLASH-3K-55		FLASH-6K-55		FLASH-10K-55	
<b>MAX AVERAGE POWER (CONTINUOUS)</b>	500 W		3 000 W		6 000 W		10 000 W	
<b>EFFECTIVE APERTURE</b>	55 mm Ø		55 mm Ø		55 mm Ø		55 mm Ø	
<b>COOLING METHOD</b>	Convection		Convection		Convection		Convection	
<b>MEASUREMENT CAPABILITY</b>								
Spectral Range	0.19 – 20 µm		0.19 – 20 µm		0.19 – 20 µm		0.19 – 20 µm	
Maximum Measurable Power	500 W		3000 W		6000 W		10000 W	
Available Wavelengths	CO <sub>2</sub> , YAG, Custom (250 - 2500 nm) - Up to 3 Calibrations/Unit							
Noise Equivalent Power	0.1 W		5 W		20 W		30 W	
Response Time	5 sec		10 sec		5 sec		5 sec	
Calibration Uncertainty	±3 %		±5 %		±5 %		±5 %	
Number of Readings Before Cooling	100 W	25 (200 sec)	0.5 kW	6 (72 sec)	1 kW	6 (36 sec)	1 kW	10 (60 sec)
(Maximum Exposure Time Before Cooling)	200 W	12 (100 sec)	1 kW	3 (36 sec)	2 kW	3 (18 sec)	2 kW	5 (30 sec)
	300 W	8 (60 sec)	1.5 kW	2 (24 sec)	3 kW	2 (12 sec)	5 kW	2 (12 sec)
	500 W	5 (40 sec)	3 kW	1 (12 sec)	6 kW	1 (6 sec)	10 kW	1 (6 sec)
<b>DAMAGE THRESHOLDS</b>								
Maximum Average Power Density								
1064 nm, 100 W, CW	25 kW/cm <sup>2</sup>		---		---		---	
1064 nm, 500 W, CW	5 kW/cm <sup>2</sup>		7 kW/cm <sup>2</sup>		---		---	
1064 nm, 3000 W, CW	---		5 kW/cm <sup>2</sup>		8 kW/cm <sup>2</sup>		---	
1064 nm, 6000 W, CW	---		---		7 kW/cm <sup>2</sup>		7 kW/cm <sup>2</sup>	
1064 nm, 10000 W, CW	---		---		-		5.5 kW/cm <sup>2</sup>	
Maximum Allowable Absorber Temperature	65 °C		65 °C		75 °C		75 °C	
<b>GENERAL SPECIFICATIONS</b>								
Digital Display	40 x 20 mm		40 x 20 mm		40 x 20 mm		40 x 20 mm	
Battery Type	2 x AA batteries, 3.0 V		2 x AA batteries, 3.0 V		2 x AA batteries, 3.0 V		2 x AA batteries, 3.0 V	
Battery Life	>5000 measurements		>5000 measurements		>5000 measurements		>5000 measurements	
Operating Temperature Range	10 to 40 °C		10 to 40 °C		10 to 40 °C		10 to 40 °C	
Storage Temperature Range	10 to 60 °C		10 to 60 °C		10 to 60 °C		10 to 60 °C	
<b>PHYSICAL CHARACTERISTICS</b>								
Effective Aperture	55 mm Ø		55 mm Ø		55 mm Ø		55 mm Ø	
Dimensions (Sensor Head, Monitor and Handle)	335H x 88W x 35D mm		335H x 88W x 45D mm		335H x 88W x 36D mm		335H x 88W x 46D mm	
Weight	930 g		1240 g		1520 g		2150 g	
<b>ORDERING INFORMATION</b>								
Common Product Name	FLASH-500-55		FLASH-3K-55		FLASH-6K-55		FLASH-10K-55	
Add Extension for Cable	-C		-C		-C		-C	
Product Number	201244	201959	201245	201973	201851	201975	201868	201977

Specifications are subject to change without notice

# BEAM DUMPS

Water-Cooled Beam Dumps for High Power Lasers



## KEY FEATURES

1. **EASY-TO-USE**  
Just plug the water-cooling and you're done!
2. **2 MODELS TO CHOOSE FROM**
  - 4 kW: BD-4KW-HE
  - 12 kW: BD-12KW-HD
3. **VERY LARGE APERTURE**  
The round aperture of 100 mm in diameter accommodates even the largest beams
4. **HIGH DAMAGE THRESHOLDS**  
Up to 16 kW/cm<sup>2</sup> (at 500 W)
5. **ISOLATION TUBE IN OPTION**  
It is possible to add an isolation tube to reduce back reflections

## AVAILABLE MODELS



BD-4KW-HE  
4 kW Beam Dump



BD-12KW-HD  
12 kW Beam Dump

## ACCESSORIES



Stand with Steel Post  
(Model Number: 201102)



Pelican Carrying Case

## SEE ALSO

UP55-HD	96
HP	98
SUPER HP	100
LIST OF ALL ACCESSORIES	184

# BEAM DUMPS

## SPECIFICATIONS

	BD-4KW-HE	BD-12KW-HD
<b>MAX AVERAGE POWER (CONTINUOUS / 2 MINUTES)</b>	4 000 W / 4 500 W	12 000 W / 12 000 W
<b>EFFECTIVE APERTURE</b>	100 mm Ø	100 mm Ø
<b>COOLING METHOD</b>	Water-Cooled	Water-Cooled
<b>DAMAGE THRESHOLDS</b>		
Maximum Average Power Density <sup>a</sup>		
500 W	10 kW/cm <sup>2</sup>	16 kW/cm <sup>2</sup>
4 kW	4 kW/cm <sup>2</sup>	---
5 kW	---	6.5 kW/cm <sup>2</sup>
10 kW	---	3.5 kW/cm <sup>2</sup>
<b>PHYSICAL CHARACTERISTICS</b>		
Effective Aperture	100 mm Ø	100 mm Ø
Absorber (High Damage Threshold)	HE	HD
Required Cooling Flow	(4 - 6) LPM < ±1 LPM/min <sup>b</sup>	(6 - 10) LPM < ±1 LPM/min <sup>b</sup>
Temperature of Cooling Water	(15 - 25) °C < ±3°C/min <sup>b</sup>	(15 - 25) °C < ±3°C/min <sup>b</sup>
Dimensions	127H x 127W x 74D mm	127H x 127W x 70D mm
Weight (head only)	1.8 kg	3.3 kg
<b>ORDERING INFORMATION</b>		
Product Name	BD-4KW-HE	BD-12KW-HD

Specifications are subject to change without notice

a. At 1064 nm, 1.07-1.08 µm and 10.6 µm.

b. > 1 min. Contact Gentec-EO for clean deionized water cooling module option.

MONITORS

ENERGY DETECTORS

POWER DETECTORS

HIGH POWER SOLUTIONS

PHOTO DETECTORS

THZ DETECTORS

OEM DETECTORS

SPECIAL PRODUCTS

BEAM DIAGNOSTICS

# TECHNICAL DRAWINGS

All dimensions in mm

## UP55G-600F-HD

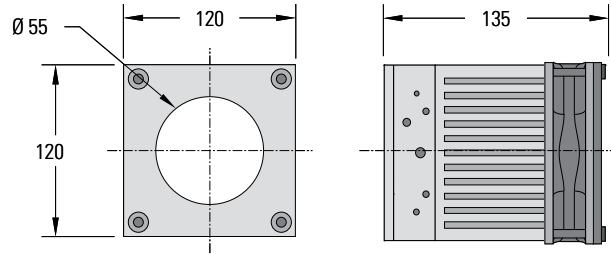

View

FRONT

S-SIDE

## UP55M-700W-HD

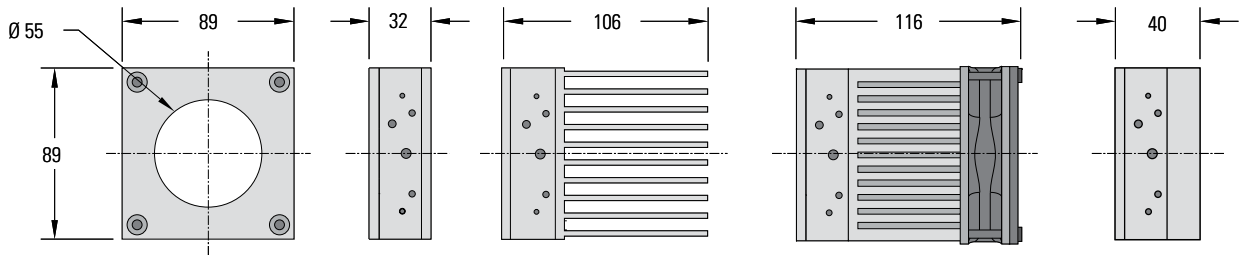

View

FRONT

S-SIDE

H-SIDE

F-SIDE

W-SIDE

## UP55C-2.5KW-HD

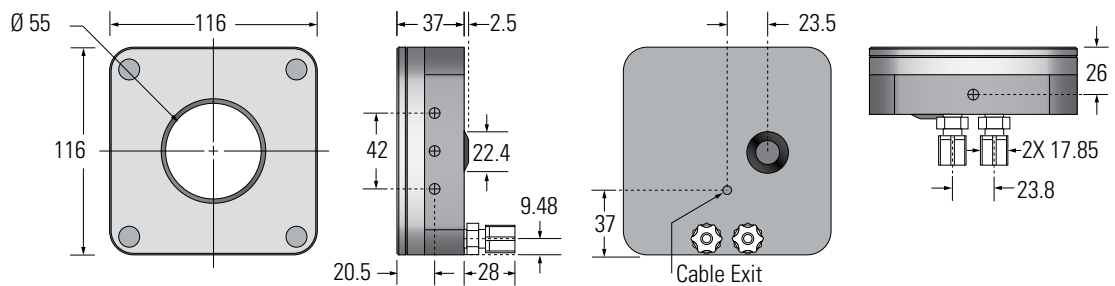

View

FRONT

SIDE

REAR

BOTTOM

## HP100A

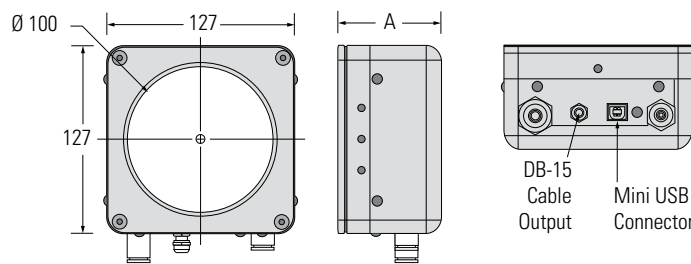

MODEL	DIM. A
4KW	74
12KW	70

View

FRONT

SIDE

BOTTOM

# TECHNICAL DRAWINGS

All dimensions in mm

## HP60A-10KW-GD

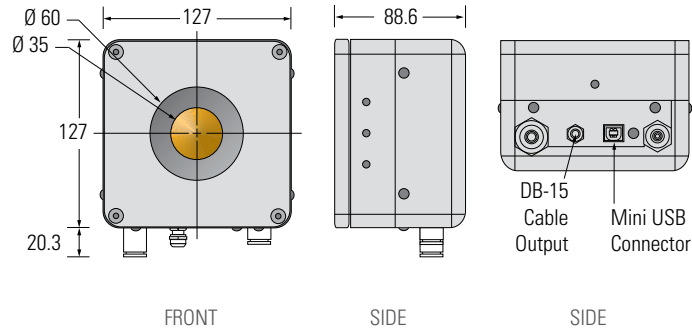

View

FRONT

SIDE

SIDE

## FLASH-500-55

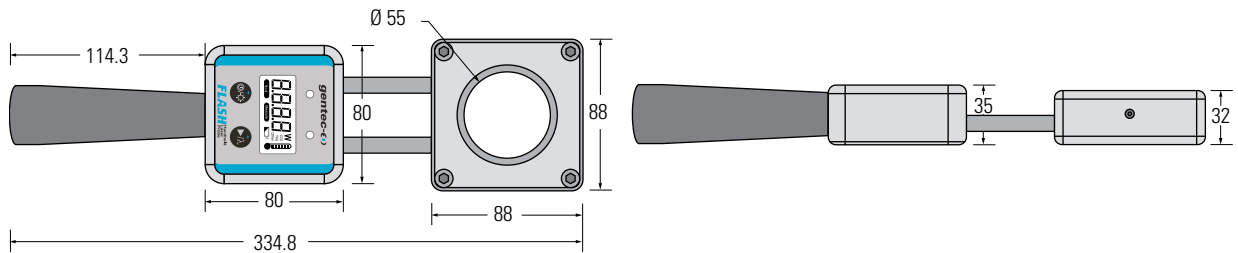

View

FRONT

SIDE

## FLASH-3K/6K/10K-55

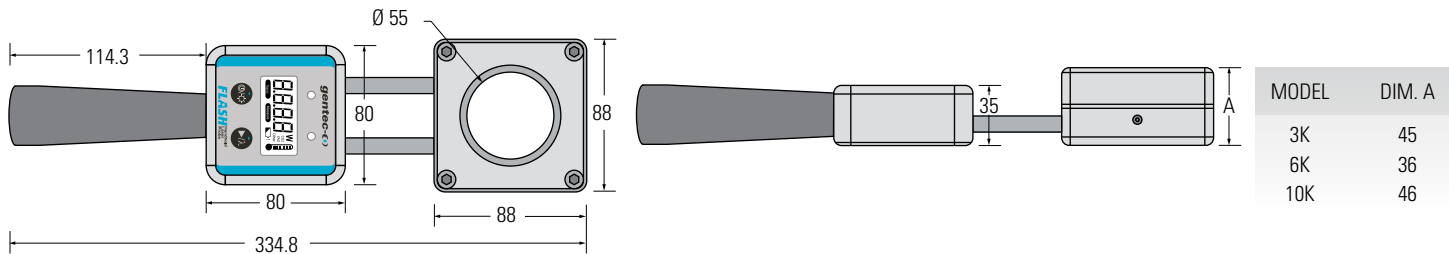

View

FRONT

SIDE

## BEAM DUMPS

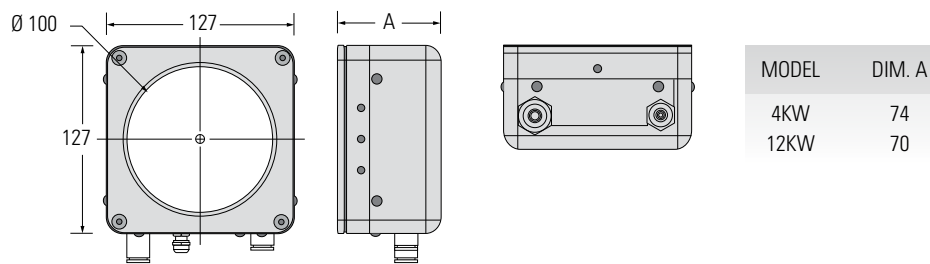

View

FRONT

SIDE

BOTTOM

# PRESENTATION

## OVERVIEW OF THE DIFFERENT MODELS

Our photo detectors are offered for both power or energy measurements. Measure as low as a few femtojoules in energy or a few picowatts in power.

### FOR POWER MEASUREMENTS

The section below lists all the photo detectors used for power measurements. The corresponding comparison table and power range chart are given at the next page.

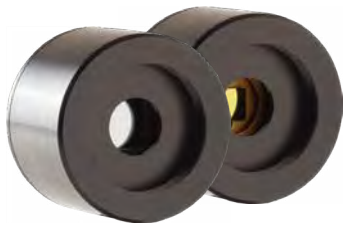

See page **110**

#### PH-B

- 5 and 10 mm Ø Apertures
- UV-Silicon and Germanium Sensors
- Very Low Powers, down to the pW level

■ NOISE DOWN TO THE pW LEVEL



Available with  
*integra*

See page **112**

#### PH

- High Power Photo Detectors for measurements up to 750 mW
- Available from UV to IR
- Silicon, UV-Silicon and Germanium Sensors
- OD1/OD2 Attenuators Available

■ HIGH POWER Si OR Ge SENSORS

### FOR ENERGY MEASUREMENTS

The section below lists all the photo detectors used for energy measurements. The corresponding comparison table and energy range chart are given at the next page.

Available with  
*integra*



See page **114**

#### PE-B

- 3, 5 and 10 mm Ø Apertures
- Germanium and InGaAs Sensors
- Lowest Noise Level of ALL Energy Detectors (8 fJ with PE3B-Si)

■ 8 fJ NOISE LEVEL

# COMPARISON TABLE

## FOR POWER MEASUREMENTS

MODEL	P <sub>MAX</sub>	NOISE LEVEL	λ <sub>MIN</sub>	λ <sub>MAX</sub>	SENSOR TYPE	APERTURE	SEE PAGE
PH5B-Ge	40 μW	40 pW	800 nm	1.65 μm	Germanium	5 mm Ø	110
PH10B-Si	200 μW	50 pW	210 nm	1.08 μm	UV-Silicon	10 mm Ø	110
PH100-SiUV	4 mW	10 pW	210 nm	1.08 μm	UV-Silicon	10 mm Ø	112
PH100-SiUV-OD.3	11 mW	30 pW	210 nm	1.08 μm	UV-Silicon	10 mm Ø	112
PH100-SiUV-OD1	38 mW	100 pW	400 nm	1.08 μm	UV-Silicon	10 mm Ø	112
PH20-Ge	30 mW	60 pW	800 nm	1.65 μm	Germanium	5 mm Ø	112
PH100-Si-HA	36 mW	10 pW	350 nm	1.08 μm	Silicon	10 mm Ø	112
PH100-Si-HA-OD1	300 mW	100 pW	420 nm	1.08 μm	Silicon	10 mm Ø	112
PH20-Ge-OD1	300 mW	600 pW	900 nm	1.65 μm	Germanium	5 mm Ø	112
PH20-Ge-OD2	500 mW	6 nW	950 nm	1.65 μm	Germanium	5 mm Ø	105
PH100-Si-HA-OD2	750 mW	1 nW	630 nm	1.1 μm	Silicon	10 mm Ø	112

## FOR ENERGY MEASUREMENTS

MODEL	E <sub>MAX</sub>	NOISE LEVEL	λ <sub>MIN</sub>	λ <sub>MAX</sub>	SENSOR TYPE	APERTURE	SEE PAGE
PE3B-Si	30 pJ	8 fJ	210 nm	1.08 μm	UV-Silicon	3 mm Ø	114
PE3B-In	300 pJ	30 fJ	900 nm	1.7 μm	InGaAs	3 mm Ø	114
PE5B-Ge	3 nJ	1 pJ	800 nm	1.65 μm	Germanium	5 mm Ø	114
PE10B-Si	150 nJ	1.5 pJ	210 nm	1.08 μm	UV-Silicon	10 mm Ø	114

 Available with INTEGRA all-in-one detector + meter

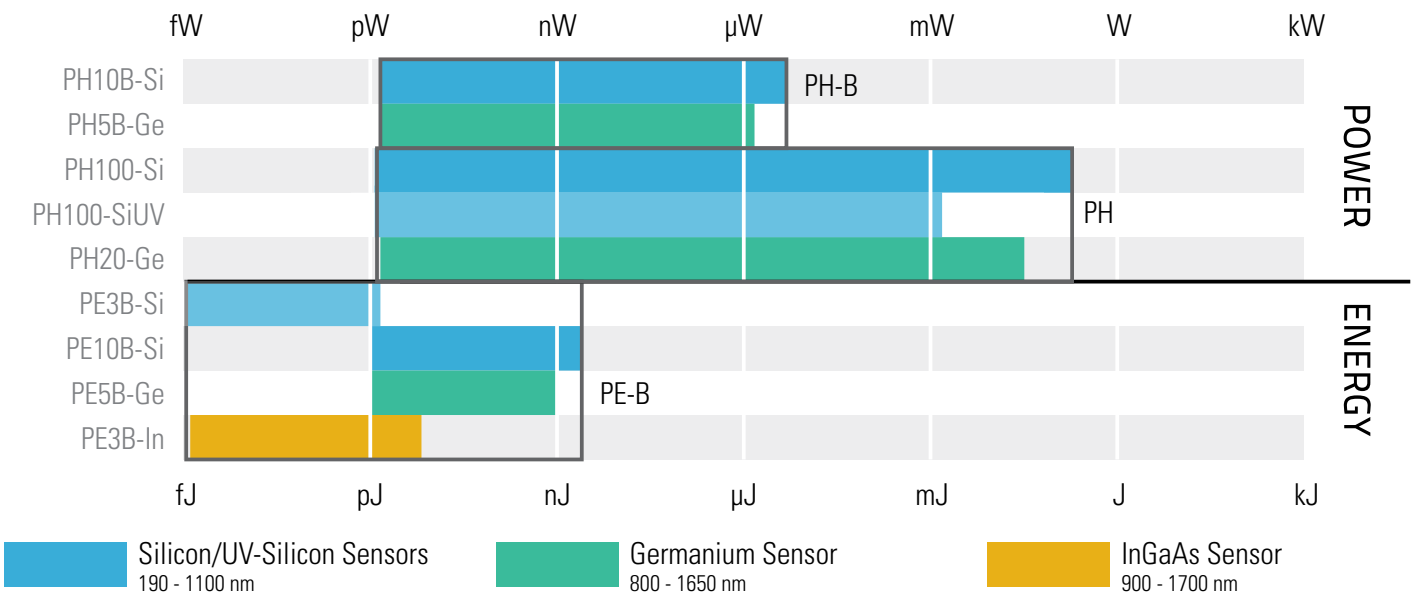

# PH-B

40 pW - 200  $\mu$ W, Our Lowest Power Measurements



## KEY FEATURES

1. **VERY SENSITIVE PHOTO DETECTOR**  
Measure down to the pW level
2. **2 SENSORS AVAILABLE**
  - PH10B-Si: 10 mm  $\varnothing$ , UV-Silicon sensor for 0.21 to 1.08  $\mu$ m
  - PH5B-Ge: 5 mm  $\varnothing$ , Germanium sensor for 0.8 to 1.65  $\mu$ m
3. **SMART INTERFACE**  
Containing all the calibration data

## AVAILABLE MODELS



PH10B-Si  
(10 mm - UV-Silicon)



PH5B-Ge  
(5 mm - Germanium)

## ACCESSORIES



Stand with Delrin Post  
(Model Number: 200428)



Fiber Adaptors & Connectors  
(FC, ST or SMA)



APM Analog Power Supply  
(Model Number: 201848)



Pelican Carrying Case

## SEE ALSO

TECHNICAL DRAWINGS	<b>116</b>
ABSORPTION CURVES	<b>117</b>
COMPATIBLE MONITORS	
MAESTRO	<b>20</b>
S-LINK	<b>28</b>
M-LINK	<b>32</b>
LIST OF ALL ACCESSORIES	<b>184</b>

## APPLICATION NOTE

CALIBRATION UNCERTAINTY  
OF PHOTO DETECTORS

[202174](#)

## PH-B



\*Also traceable to NRC-CNRC

## SPECIFICATIONS

	PH10B-Si	PH5B-Ge
<b>MAX AVERAGE POWER</b>	200 $\mu$ W	40 $\mu$ W
<b>EFFECTIVE APERTURE</b>	10 mm $\emptyset$	5 mm $\emptyset$
<b>MEASUREMENT CAPABILITY</b>		
Spectral Range	0.21 - 1.08 $\mu$ m	0.8 - 1.65 $\mu$ m
Maximum Measurable Power		
With M-LINK	200 $\mu$ W @ 633 nm	40 $\mu$ W @ 1310 nm
With S-LINK	175 $\mu$ W @ 633 nm	30 $\mu$ W @ 1310 nm
With MAESTRO	150 $\mu$ W @ 633 nm	25 $\mu$ W @ 1310 nm
Noise Equivalent Power <sup>a</sup>	50 pW @ 633 nm	40 pW @ 1310 nm
Rise Time (0-100%)	$\leq$ 0.2 s	$\leq$ 0.2 s
Peak Sensitivity	15 kV/W @ 633 nm	80 kV/W @ 1047 nm
Calibration Uncertainty <sup>b</sup>	$\pm$ 8 % (210 - 219 nm)	$\pm$ 3.5% (800 - 1650 nm)
	$\pm$ 6.5 % (220 - 399 nm)	
	$\pm$ 2.5 % (400 - 899 nm)	
	$\pm$ 3.5 % (900 - 999 nm)	
	$\pm$ 5 % (1000 - 1049 nm)	
	$\pm$ 7 % (1050 - 1080 nm)	
<b>DAMAGE THRESHOLDS</b>		
Maximum Average Power Density	100 W/cm <sup>2</sup>	100 W/cm <sup>2</sup>
<b>PHYSICAL CHARACTERISTICS</b>		
Effective Aperture	10 mm $\emptyset$	5 mm $\emptyset$
Distance to Sensor Face	13.7 mm	10.5 mm
Sensor	UV-Silicon	Germanium
Dimensions	38.1 $\emptyset$ x 27.4D mm	38.1 $\emptyset$ x 27.4D mm
Weight	91 g	91 g
<b>ORDERING INFORMATION</b>		
Product Name	PH10B-Si	PH5B-Ge
Product Number (Including stand)	202820	202821

Specifications are subject to change without notice

- a. Nominal value, depends on environmental electromagnetic interference and wavelength.  
 b. With a Gentec-E0 monitor.



# PH

10 pW to 750 mW, Si and Ge Sensors



## KEY FEATURES

1. **LARGE APERTURES**  
10 mm Ø for the Silicon sensors
2. **3 VERSIONS**
  - Silicon: 350 - 1080 nm, up to 750 mW
  - Silicon-UV: 210 - 1080 nm, up to 25 mW
  - Germanium: 800 - 1650 nm, up to 500 mW
3. **CHOICE OF ATTENUATORS**
  - OD0.3: 50 % Transmission (for PH100-Si<sup>UV</sup> only)
  - OD1: 10 % Transmission
  - OD2: 1 % Transmission
4. **HIGH ACCURACY**  
The new PH100-Si-HA presents the lowest calibration uncertainty to date
5. **PRECISE CALIBRATION**  
Wavelength selection in 1 nm steps
6. **SMART INTERFACE**  
Containing all the calibration data

## AVAILABLE MODELS



PH100-Si-HA  
(10 mm - Silicon)



PH100-Si<sup>UV</sup>  
(10 mm - UV-Silicon)



PH20-Ge  
(5 mm - Germanium)

## OD ATTENUATORS

OD Attenuators sold in option. When bought together, the detector is calibrated with and without the attenuator.



PH Series Detector  
With OD Attenuator

## ACCESSORIES



Stand with Delrin Post  
(Model Number: 200428)



Fiber Adaptors & Connectors  
(FC, SC, ST and SMA)



OD Attenuators



Pelican Carrying Case

## SEE ALSO

TECHNICAL DRAWINGS	<b>116</b>
ABSORPTION CURVES	<b>117</b>
COMPATIBLE MONITORS	
MAESTRO	<b>20</b>
TUNER	<b>24</b>
UNO	<b>26</b>
P-LINK	<b>30</b>
M-LINK	<b>32</b>
LIST OF ALL ACCESSORIES	<b>184</b>

## APPLICATION NOTE

CALIBRATION UNCERTAINTY  
OF PHOTO DETECTORS

[202174](#)

MONITORS

ENERGY DETECTORS

POWER DETECTORS

HIGH POWER SOLUTIONS

PHOTO DETECTORS

THZ DETECTORS

OEM DETECTORS

SPECIAL PRODUCTS

BEAM DIAGNOSTICS

PH



\*Also traceable to NRC-CNRC

## SPECIFICATIONS

	PH100-Si-HA	PH100-Si <sup>UV</sup>	PH20-Ge			
<b>MAX AVERAGE POWER (ALONE / WITH OD2)</b>	36 mW / 750 mW	4 mW / 30 mW	30 mW / 500 mW			
<b>EFFECTIVE APERTURE</b>	10 mm Ø	10 mm Ø	5 mm Ø			
<b>MEASUREMENT CAPABILITY</b>						
Spectral Range	350 – 1080 nm	210 – 1080 nm	800 – 1650 nm			
With OD0.3	---	210 – 1080 nm	---			
With OD1	420 – 1080 nm	400 – 1080 nm	900 – 1650 nm			
With OD2	630 – 1080 nm	---	950 – 1650 nm			
Maximum Measurable Power <sup>a</sup>	36 mW @ 1064 nm	4 mW @ 532 nm	30 mW @ 1064 nm			
With OD0.3	---	11 mW @ 300 nm	---			
With OD1	300 mW @ 1064 nm	38 mW @ 532 nm	300 mW @ 1064 nm			
With OD2	750 mW @ 1064 nm	---	500 mW @ 1064 nm			
Noise Equivalent Power <sup>b</sup>	10 pW @ 980 nm	10 pW @ 850 nm	60 pW @ 1550 nm			
Rise Time (nominal)	0.2 sec	0.2 sec	0.2 sec			
Peak Sensitivity	0.5 A/W @ 980 nm	0.45 A/W @ 850 nm	0.98 A/W @ 1550 nm			
Calibration Uncertainty	±6.0 % (350 - 399 nm)	±8 % (200 - 219 nm)	±3.5 % (800 - 1650 nm)			
	±2.0 % (400 - 449 nm)	±6.5 % (220 - 399 nm)	---			
	±1.5 % (450 - 940 nm)	±2.5 % (400 - 899 nm)	---			
	±2.0 % (941 - 980 nm)	±3.5 % (900 - 999 nm)	---			
	±5.0 % (981 - 1049 nm)	±5 % (1000 - 1049 nm)	---			
	±7.0 % (1050 - 1080 nm)	±7 % (1050 - 1080 nm)	---			
Calibration Uncertainty (with OD filters)	±4.0 % (420 - 980 nm)	±6.5 % (210 - 399 nm)	±5 %			
	±5.0 % (981 - 1049 nm)	±5 % (400 - 1049 nm)				
	±7.0 % (1050 - 1080 nm)	±7 % (1050 - 1080 nm)				
<b>DAMAGE THRESHOLDS</b>						
Maximum Average Power Density	100 W/cm <sup>2</sup>	100 W/cm <sup>2</sup>	100 W/cm <sup>2</sup>			
<b>PHYSICAL CHARACTERISTICS</b>						
Effective Aperture	10 mm Ø	10 mm Ø	5 mm Ø			
Distance to Sensor Face	13.7 mm	13.7 mm	10.5 mm			
Sensor	Silicon	UV-Silicon	Germanium			
Dimensions	38.1Ø x 27.4D mm	38.1Ø x 27.4D mm	38.1Ø x 27.4D mm			
Weight (head only)	130 g	130 g	130 g			
<b>ORDERING INFORMATION</b>						
	Standard	Add Ext. for INTEGRA	Standard	Add Ext. for INTEGRA	Standard	Add Ext. for INTEGRA
Product Name	PH100-Si-HA	-INT	PH100-SiUV	-INT	PH20-Ge	-INT
Product Number (Including stand)	202682	202781	202806	202787	202807	202793
Product Name (with OD0.3)			PH100-SiUV-OD.3	-INT		
Product Number (Including stand)			202680	202791		
Product Name (with OD1)	PH100-Si-HA-OD1	-INT	PH100-SiUV-OD1	-INT	PH20-Ge-OD1	-INT
Product Number (Including stand)	202684	202783	202809	202789	202810	202795
Product Name (with OD2)	PH100-Si-HA-OD2	-INT			PH20-Ge-OD2	-INT
Product Number (Including stand)	202686	202785			202813	202797

Specifications are subject to change without notice

a. Maximum value depends on the monitor.

b. Nominal value. Depends on environmental electromagnetic interference and wavelength.



# PE-B

8 fJ - 150 nJ, Our Lowest Energy Measurements



## KEY FEATURES

1. **VERY LOW NOISE LEVEL**  
Take measurements with a noise level as low as 8 fJ with the M-LINK, MAESTRO and S-LINK monitors
2. **3 SENSORS AVAILABLE**
  - PE-B-Si family: 3 and 10 mm Ø Silicon sensors for 0.21 to 1.08  $\mu\text{m}$
  - PE5B-Ge: 5 mm Ø, Germanium sensor for 0.8 to 1.65  $\mu\text{m}$
  - PE3B-In: 3 mm Ø, InGaAs sensor for 0.9 to 1.7  $\mu\text{m}$
3. **SMART INTERFACE**  
Containing all the calibration data

## AVAILABLE MODELS



PE3B-Si  
(3 mm - UV-Silicon)



PE10B-Si  
(10 mm - UV-Silicon)



PE5B-Ge  
(5 mm - Germanium)



PE3B-In  
(3 mm - InGaAs)

## ACCESSORIES



Stand with Delrin Post  
(Model Number: 200428)



Fiber Adaptors & Connectors  
(FC, ST or SMA)



APM Analog Power Supply  
(Model Number: 201848)

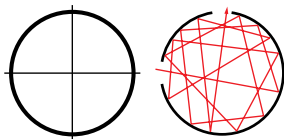

IR Alignment Aide, Crosshairs and Integrating Sphere



Pelican Carrying Case

## SEE ALSO

TECHNICAL DRAWINGS	<b>116</b>
ABSORPTION CURVES	<b>117</b>
COMPATIBLE MONITORS	
MAESTRO	<b>20</b>
S-LINK	<b>28</b>
M-LINK	<b>32</b>
LIST OF ALL ACCESSORIES	<b>184</b>

## APPLICATION NOTE

CALIBRATION UNCERTAINTY OF PHOTO DETECTORS

[202174](#)

MONITORS

ENERGY DETECTORS

POWER DETECTORS

HIGH POWER SOLUTIONS

PHOTO DETECTORS

THZ DETECTORS

OEM DETECTORS

SPECIAL PRODUCTS

BEAM DIAGNOSTICS

## PE-B



\*Also traceable to NRC-CNRC

## SPECIFICATIONS

	PE3B-Si	PE10B-Si	PE5B-Ge	PE3B-In
<b>MAX MEASURABLE ENERGY</b>	30 $\mu$ J	150 nJ	3 nJ	300 $\mu$ J
<b>EFFECTIVE APERTURE</b>	3 mm $\emptyset$	10 mm $\emptyset$	5 mm $\emptyset$	3 mm $\emptyset$
<b>MEASUREMENT CAPABILITY</b>				
Spectral Range	0.21 - 1.08 $\mu$ m	0.21 - 1.08 $\mu$ m	0.8 - 1.65 $\mu$ m	0.9 - 1.7 $\mu$ m
Maximum Measurable Energy				
With M-LINK	30 $\mu$ J @ 634 nm	150 nJ @ 634 nm	3 nJ @ 1310 nm	300 $\mu$ J @ 1310 nm
With S-LINK	25 $\mu$ J @ 634 nm	130 nJ @ 634 nm	2.5 nJ @ 1310 nm	250 $\mu$ J @ 1310 nm
With MAESTRO	20 $\mu$ J @ 634 nm	110 nJ @ 634 nm	2 nJ @ 1310 nm	200 $\mu$ J @ 1310 nm
Noise Equivalent Energy <sup>a</sup>	8 fJ @ 634 nm	1.5 $\mu$ J @ 634 nm	1 $\mu$ J @ 1310 nm	30 fJ @ 1310 nm
Rise Time (0-100%)	15 $\mu$ s	30 $\mu$ s	25 $\mu$ s	12 $\mu$ s
Max Repetition Rate	1000 Hz	1000 Hz	1000 Hz	1000 Hz
Max Pulse Width	10 $\mu$ s	10 $\mu$ s	10 $\mu$ s	10 $\mu$ s
Sensitivity	100 GV/J @ 634 nm	20 MV/J @ 634 nm	1 GV/J @ 1310 nm	10 GV/J @ 1310 nm
Calibration Uncertainty <sup>b</sup>	$\pm$ 4% <sup>c</sup>	$\pm$ 8% (210 - 219 nm)	$\pm$ 3.5%	$\pm$ 4% <sup>d</sup>
		$\pm$ 6.5% (220 - 399 nm)		
		$\pm$ 2.5% (400 - 899 nm)		
		$\pm$ 3.5% (900 - 999 nm)		
		$\pm$ 5% (1000 - 1049 nm)		
		$\pm$ 7% (1050 - 1080 nm)		
<b>DAMAGE THRESHOLDS</b>				
Max Energy Density	N/A	5 $\mu$ J/cm <sup>2</sup>	5 $\mu$ J/cm <sup>2</sup>	N/A
Max Average Power Density	N/A	65 mW/cm <sup>2</sup> @ 532 nm	320 mW/cm <sup>2</sup> @ 1064 nm	N/A
<b>PHYSICAL CHARACTERISTICS</b>				
Effective Aperture	3 mm $\emptyset$	10 mm $\emptyset$	5 mm $\emptyset$	3 mm $\emptyset$
Distance to Sensor Face	13.7 mm	13.7 mm	10.5 mm	N/A
Sensor	UV-Silicon	UV-Silicon	Germanium	InGaAs
Dimensions	38.1 $\emptyset$ x 27.4D mm	38.1 $\emptyset$ x 27.4D mm	38.1 $\emptyset$ x 27.4D mm	38.1 $\emptyset$ x 27.4D mm
Weight	91 g	91 g	91 g	91 g
<b>ORDERING INFORMATION</b>				
Product Name	PE3B-Si	PE10B-Si	PE5B-Ge	PE3B-In
Product Number (Including stand)		202822	202825	
Add Extension for INTEGRA	-INT	-INT	-INT	-INT

Specifications are subject to change without notice

- a. Nominal value. Depends on environmental electromagnetic interference and wavelength.  
b. With Gentec-EO monitor.  
c. This detector is NIST Traceable at the calibration wavelength of 634 nm. Typical values are used at other wavelengths.  
d. This detector is NIST Traceable at the calibration wavelength of 1310 nm. Typical values are used at other wavelengths.

# TECHNICAL DRAWINGS

All dimensions in mm

PH10B-Si PH100-Si/Si<sup>UV</sup> PE10B-Si

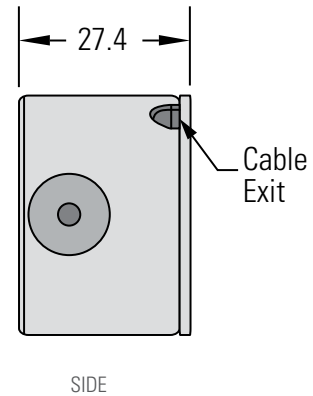
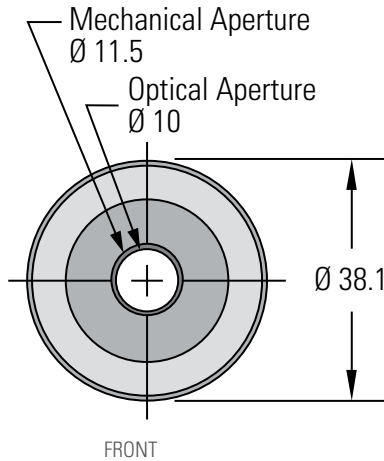

View

PH5B-Ge PH20-Ge PE5B-Ge

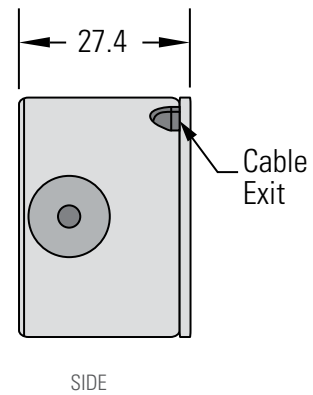
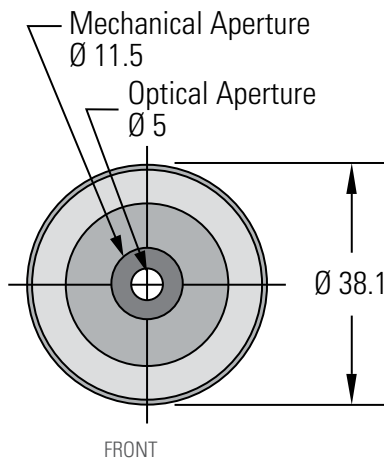

View

PE3B-In

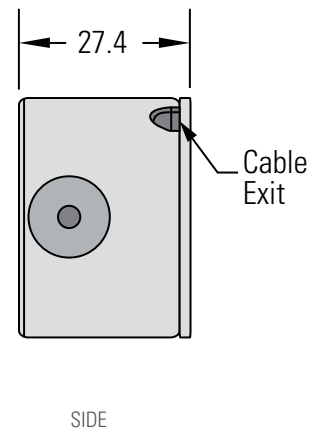
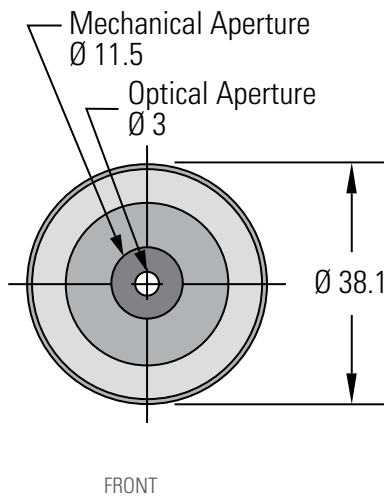

View

MONITORS  
ENERGY DETECTORS  
POWER DETECTORS  
HIGH-POWER SOLUTIONS  
PHOTO DETECTORS  
THZ DETECTORS  
OEM DETECTORS  
SPECIAL PRODUCTS  
BEAM DIAGNOSTICS

# ABSORPTION CURVES

PH-B / PE-B

Absorptance

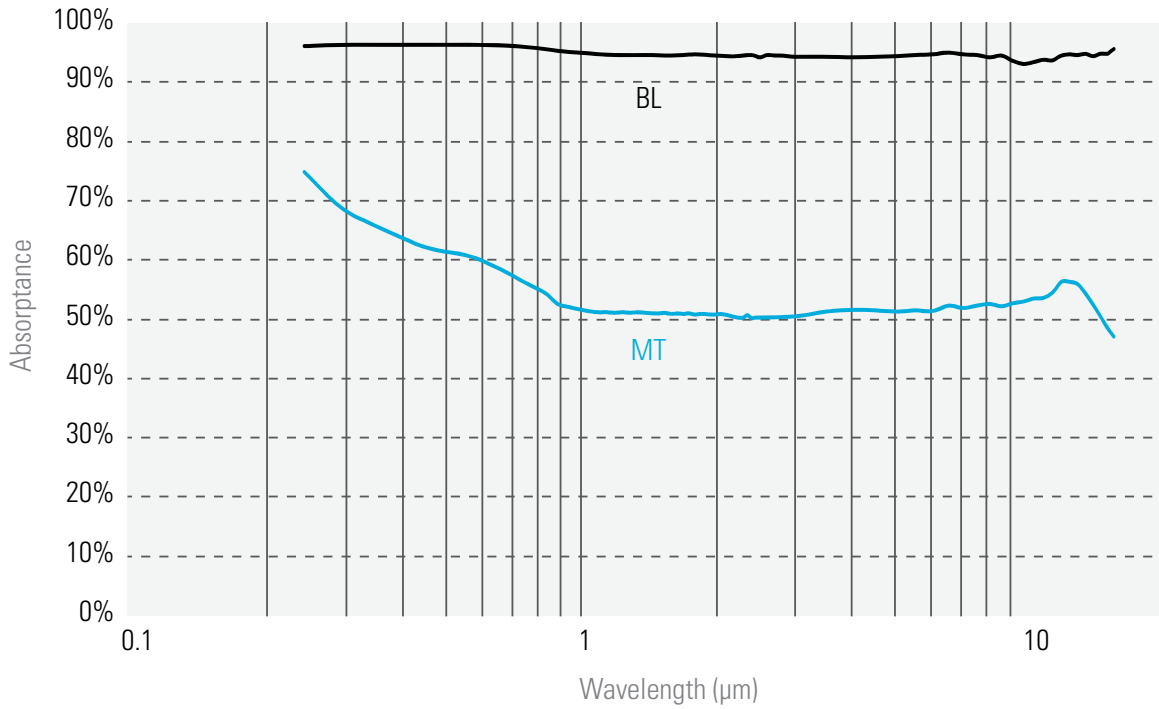

Relative Response

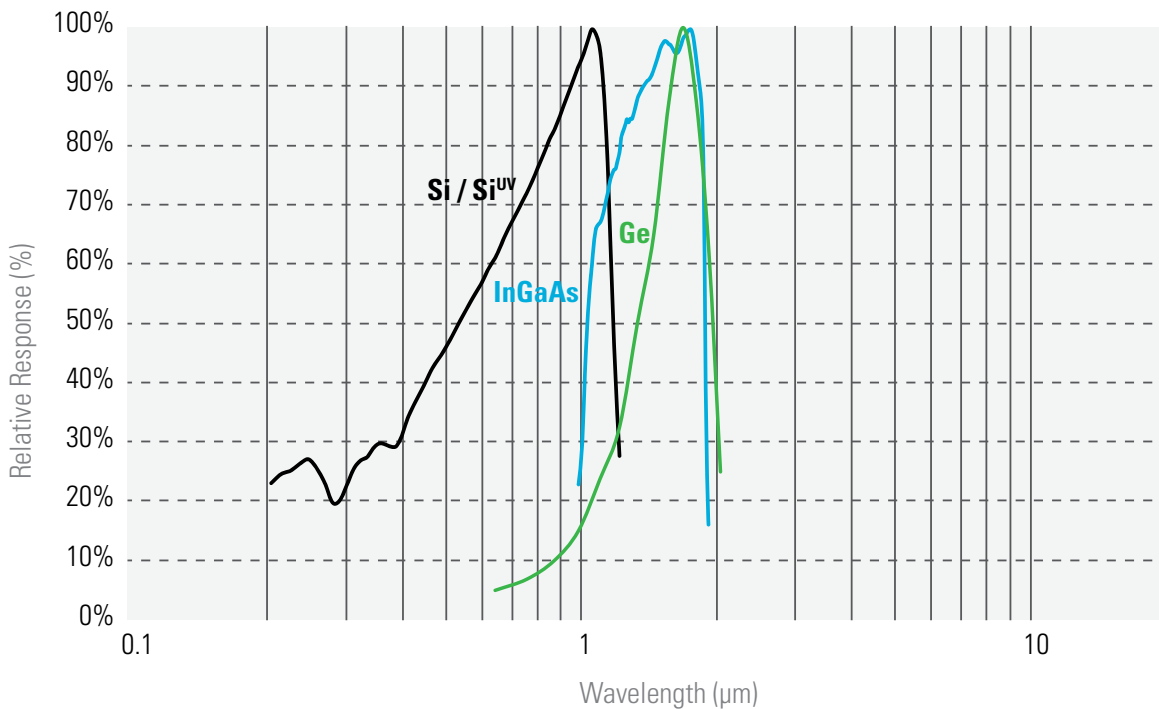

# PRESENTATION

## WHAT IS TERAHERTZ RADIATION?

The THz portion of the electromagnetic spectrum fills the gap between the far infrared and the microwaves. More precisely, it is nestled between the high-frequency edge of the microwave band, 300 GHz ( $3 \times 10^{11}$  Hz), and the long-wavelength edge of far-infrared light, 3000 GHz ( $3 \times 10^{12}$  Hz or 3 THz). In wavelengths, this range corresponds to 0.1 mm (or 100  $\mu\text{m}$ ) infrared to 1.0 mm microwave. The THz band is set in the region where electromagnetic physics can best be described by its wave-like characteristics (microwave) and its particle-like characteristics (infrared).<sup>a</sup>

Figure 1.

The electromagnetic spectrum showing the THz gap from 1000  $\mu\text{m}$  to 100  $\mu\text{m}$  or 3 THz to 0.3 THz

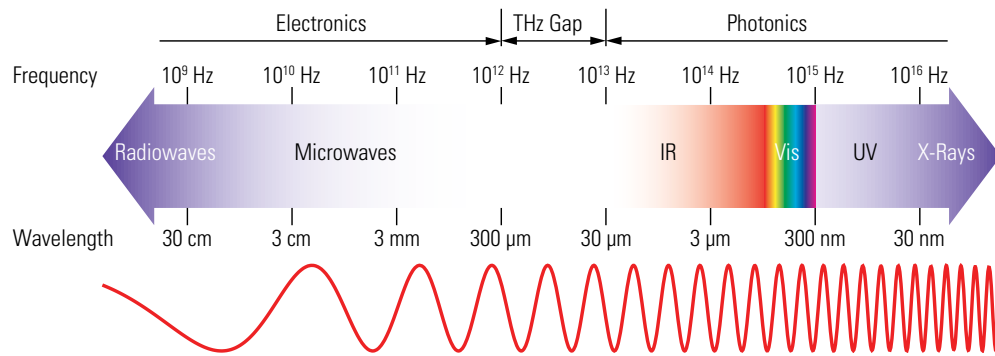

## WHAT IS IT USED FOR?

THz radiation is interesting because of the way it interacts with matter:

- It can penetrate things like wood, plastics, clothing, and other materials.
- It is also absorbed by water, or a material that contains water, like human skin.
- It is non-ionizing and therefore not harmful to humans like X-rays can be.

One of the first uses is the “full body scan” used at airports. It also has uses in medical applications for early detection of cancer cells.

## HOW IS IT MEASURED?

THz sources come in many varieties, including those with CW or Pulsed outputs. They range in power from nW to mW and in energy from nJ to mJ. Like most electromagnetic sources, they must be characterized for performance and/or control.

Older THz detection methods include:

- Golay Cells
- Micro-bolometers
- Pyroelectric detector and electrical devices like photo-acoustic and Schottky diode detectors

## WHY ARE GENTEC-EO PRODUCTS BETTER?

- **Golay Cells** used to be the detector of choice, but they are costly and often very large.
- **Pyroelectric Detectors** (like the ones used in our THz Detectors) used to have lower performances, but recent advances placed them on the same technical level as Golay Cells, and even higher. Pyroelectric Detectors in THz measuring show several benefits to the user:
  - Broadband thermal response from 0.25 to 3000  $\mu\text{m}$
  - Can be used at room temperature with high sensitivity (measure nW of power and nJ of energy)
  - Wider power range (from nW to mW)
  - Lower cost

a. Source: Wikipedia

# PRESENTATION

## OVERVIEW OF THE DIFFERENT MODELS

We have a unique line of sensors and meters for the terahertz region. You can choose either a standalone device with on-board electronics or go with our T-Rad meter and a separate sensor. We also have small terahertz detectors that come as discrete pyroelectric units for integration.



### THZ-D

- Flatest Spectral Response:  
Get the best precision across the entire THz range
- Works with our standard universal monitors:  
MAESTRO and M-LINK
- Large Apertures of 9 and 12 mm Ø

- FLATEST SPECTRAL RESPONSE IN THE THz
- WORKS WITH OUR STANDARD MONITORS

See page **120**

### THZ-I-BNC

- THz Detectors with Integrated Analog (BNC) Module (no need for a monitor)
- Wide Dynamic Range from nW to  $\mu$ W
- BNC output:
  - Battery or AC Powered (for use with an oscilloscope)
  - Very Low Noise Level (0.4 nW for THZ21-BL-BNC)

- INTEGRATED BNC MODULE

See page **122**

### THZ-B

- Large Choice of Apertures:  
1.5 mm, 5 mm and 9 mm Ø
- High Average Powers:  
Up to 200 mW with the 5 and 9 mm probes
- Choice between Digital (T-Rad) or Analog Modules (T-Rad-Analog)
- User-Friendly Software (when used with the T-Rad module)

- WORKS WITH OUR T-Rad MODULES

See page **124**

### QS-THZ

- Hybrid Pyroelectric Detectors
- Small TO5/TO8 Packages
- Available in 3 Sizes: 2 x 2, 5 and 9 mm Ø Apertures
- Wide Dynamic Range from nW to mW
- QS-I-TEST Test Box Available

- DISCRETE PYROELECTRIC DETECTORS
- SMALL TO5/TO8 PACKAGES

See page **128**



# THZ-D

THz Detectors for use with our universal monitors



## AVAILABLE MODELS



THZ12D-3S-VP  
(3W-Volume Absorber)



THZ9D-20mS-BL  
(9 mm-Organic Black)

## ACCESSORIES



Stand with Steel Post  
(Model Number: 200160)



Extension Cables  
(4, 15, 20 or 25 m)



SDC-500 Digital  
Optical Chopper



Pelican Carrying Case

## KEY FEATURES

- RELATIVE MEASUREMENTS FROM 0.1 TO 30 THz**  
Broadband, room temperature operation, easier to use and less expensive than a Golay cell
- FLAT SPECTRAL RESPONSE**  
Get the best precision across the entire wavelength range
- MEASURE HIGHER POWERS**  
Up to 3 W of continuous power with the THZ12D model, the highest in our terahertz range of products
- USE WITH A UNIVERSAL MONITOR**  
No need for an exclusive monitor. These unique THz detectors work with our standard universal monitors:
  - MAESTRO
  - M-LINK
- LARGE APERTURES**  
Models range from 9 to 12 mm Ø aperture
- CALIBRATED AT 10.6 μm**  
THZ-D detectors are calibrated at a single wavelength (10.6 μm) and include typical wavelength correction data from 10.6 to 440 μm. They are used for relative measurements outside that range

## SEE ALSO

HOW IT WORKS	14
TECHNICAL DRAWINGS	130
ABSORPTION CURVES	132
COMPATIBLE MONITORS	
MAESTRO	20
M-LINK	32
LIST OF ALL ACCESSORIES	184

MONITORS

ENERGY DETECTORS

POWER DETECTORS

HIGH POWER SOLUTIONS

PHOTO DETECTORS

THZ DETECTORS

OEM DETECTORS

SPECIAL PRODUCTS

BEAM DIAGNOSTICS

## THZ-D



## SPECIFICATIONS

	THZ9D- 20mS-BL	THZ12D-3S-VP
<b>MAX AVERAGE POWER</b>	25 mW	3 W
<b>EFFECTIVE APERTURE</b>	9 mm Ø	12 mm Ø
<b>COMPATIBLE MONITORS</b>	MAESTRO, M-LINK & APM	MAESTRO & M-LINK
<b>MEASUREMENT CAPABILITY</b>		
Spectral Range <sup>a</sup>		
Frequency	0.1 - 30 THz	0.1 - 30 THz
Wavelength	3000 – 10 µm	3000 – 10 µm
Maximum Average Power		
with MAESTRO	20 mW	3 W
with M-LINK	25 mW	3 W
Noise Equivalent Power <sup>b</sup>	300 nW	0.5 µW
Minimum Measurable Power <sup>c</sup>	N/A	50 - 100 µW
Thermal Drift <sup>d</sup>	N/A	12 µW/°C
Rise Time (nominal) <sup>d</sup>	<0.2 sec	3 sec
Sensitivity (typ into 100 kΩ load) <sup>e</sup>	120 V/W	200 mV/W
Minimum Repetition Rate <sup>d</sup>	1000 Hz	7 Hz
Chopping Frequency	10 Hz (required)	N/A
Calibration Uncertainty <sup>f</sup>	±5.0 % @ 10.6 µm; ±15 % @ 10.6 - 440 µm <sup>a</sup>	±8.0 % @ 10.6 - 300 µm; ±15 % @ 300 - 440 µm <sup>a</sup>
Repeatability	±0.5 %	±0.5 %
<b>DAMAGE THRESHOLDS</b>		
Maximum Average Power Density <sup>a</sup>	50 mW/cm <sup>2</sup>	30 W/cm <sup>2</sup>
Maximum Energy Density	<0.1 J/cm <sup>2</sup>	<1 J/cm <sup>2</sup>
<b>PHYSICAL CHARACTERISTICS</b>		
Effective Aperture	9 mm Ø	12 mm Ø
Absorber (High Damage Threshold)	BL (Black Absorber)	VP (Volume Absorber)
Dimensions	38.1Ø x 26.2 mm	73H x 73W x 28D mm (80D mm with tube)
Weight (head only)	91 g	320 g
<b>ORDERING INFORMATION</b>		
Product Name	THZ9D-20mS-BL	THZ12D-3S-VP-D0
Product Number		202229

Specifications are subject to change without notice

- a. From 10 to 440 µm, spectrometer measurement with multiple laser references validation.  
From 440 to 600 µm, spectrometer measurement only.  
From 600 to 3000 µm, relative measurement only.  
This spectral range is subject to change.
- b. Nominal value, actual value depends on electrical noise in the measurement system.

- c. Actual value depends on ambient conditions and the measurement system.  
d. With Gentec-EO monitors.  
e. Maximum output voltage = sensitivity x maximum power.  
f. Including linearity with power.  
g. At 1064 nm, 1 W CW.

# THZ-I-BNC

Touch Screen, Single Channel, Power & Energy Monitor



## KEY FEATURES

- 1. RELATIVE MEASUREMENTS FROM 0.1 TO 30 THz**  
Broadband, room temperature operation, easier to use and less expensive than a Golay cell
- 2. MEASURE POWER FROM nW TO  $\mu$ W**  
With state of the art pyroelectric sensors, measure down to 50 nW with 1 nW resolution
- 3. INTEGRATED ANALOG MODULE**  
Plug the device directly into your oscilloscope or Lock-In amplifier
- 4. BATTERY OR AC POWERED**  
Includes 9V Battery and AC Power Eliminator
- 5. CALIBRATED AT 0.63  $\mu$ m**  
All THz detectors are calibrated at a single wavelength (0.63  $\mu$ m) and include typical wavelength correction data from 0.25 to 440  $\mu$ m. They are used for relative measurements outside that range.

## AVAILABLE MODELS



THZ21-BL-BNC  
(2 mm-Organic Black)



THZ51-BL-BNC  
(5 mm-Organic Black)

## ACCESSORIES



Stand with Delrin Post  
(Model Number: 200428)



Removable IR Windows  
(Various types available)



SDC-500 Digital  
Optical Chopper



Pelican Carrying Case

## SEE ALSO

TECHNICAL DRAWINGS	130
ABSORPTION CURVES	132
LIST OF ALL ACCESSORIES	184

### APPLICATION NOTES

THZ MEASUREMENT: PYROELECTRIC VS GOLAY CELL	<a href="#">201924</a>
THZ CALIBRATION	<a href="#">202155</a>
SDC-500 DIGITAL OPTICAL CHOPPER	<a href="#">202154</a>
THZ SETUP	<a href="#">202177</a>

MONITORS

ENERGY DETECTORS

POWER DETECTORS

HIGH POWER SOLUTIONS

PHOTO DETECTORS

THZ DETECTORS

OEM DETECTORS

SPECIAL PRODUCTS

BEAM DIAGNOSTICS

# THZ-I-BNC



Approved or in the process of being approved\*

## SPECIFICATIONS

	THZ2I-BL-BNC	THZ5I-BL-BNC
<b>MAX AVERAGE POWER</b>	70 $\mu$ W	140 $\mu$ W
<b>EFFECTIVE APERTURE</b>	2 x 2 mm	5 mm $\emptyset$
<b>INTEGRATED MODULE</b>	Analog (BNC)	Analog (BNC)
<b>MEASUREMENT CAPABILITY</b>		
Spectral Range <sup>a</sup>		
Frequency	0.1 - 30 THz	0.1 - 30 THz
Wavelength	3000 - 10 $\mu$ m	3000 - 10 $\mu$ m
Max Measurable Power	70 $\mu$ W	140 $\mu$ W
Noise Equivalent Power <sup>b</sup>	0.4 nW [4.0 x 10 <sup>-10</sup> W/(Hz) <sup>2</sup> ]	1.0 nW [1.0 x 10 <sup>-9</sup> W/(Hz) <sup>2</sup> ]
Rise Time (0-100%)	$\leq$ 0.2s	$\leq$ 0.2s
Sensitivity (Typical) <sup>b</sup>	140 kV/W	70 kV/W
Calibration Uncertainty	Contact Us	Contact Us
<b>DAMAGE THRESHOLDS</b>		
Maximum Average Power Density (1064 nm)	50 mW/cm <sup>2</sup>	50 mW/cm <sup>2</sup>
<b>PHYSICAL CHARACTERISTICS</b>		
Effective Aperture	2 x 2 mm	5 mm $\emptyset$
Sensor	Pyroelectric	Pyroelectric
Absorber	BL	BL
Analog Output	0-10 V	0-10 V
Dimensions	81.3 $\emptyset$ X 99.3D mm	81.3 $\emptyset$ X 99.3D mm
Weight	500 g	500 g
<b>ORDERING INFORMATION</b>		
Product Name	THZ2I-BL-BNC	THZ5I-BL-BNC
Product Number	201701	

Specifications are subject to change without notice

- a. Projected Spectral Range.  
 From 10 to 440  $\mu$ m, spectrometer measurement.  
 From 440 to 3000  $\mu$ m, relative measurement only.  
 This spectral range is subject to change.
- b. At 632 nm and a chopping frequency of 5Hz.

# THZ-B

THZ-B Detectors and T-Rad Modules



T-Rad Module

## KEY FEATURES

- 1. RELATIVE MEASUREMENTS FROM 0.1 TO 30 THz**  
Broadband, room temperature operation, easier to use and less expensive than a Golay cell
- 2. MEASURE POWER FROM nW TO mW**  
With state of the art pyroelectric sensors, measure down to 100 nW with 2 nW resolution
- 3. USE WITH T-RAD THZ MODULE OR T-RAD-ANALOG POWER MODULE**  
Each head can be connected to an oscilloscope using the analog power module (T-Rad-Analog) or directly to a PC with the digital power module (T-Rad)
- 4. SEVERAL SENSOR SIZES AVAILABLE**  
Choice of 2.5 mm, 5 mm and 9 mm diameter
- 5. CALIBRATED AT 0.63 μm**  
All THz detectors are calibrated at a single wavelength (0.63 μm) and include a typical wavelength correction data from 0.25 to 440 μm. They are used for relative measurements outside that range.
- 6. SDC-500 OPTICAL CHOPPER**  
All THz-B detectors require the use of an optical chopper, like our SDC-500, to sync the signal at either 5 Hz (DA models) or 25 Hz (DZ models)
- 7. USER-FRIENDLY SOFTWARE WITH MANY FEATURES (WITH T-RAD MODULE)**  
Strip Chart, Histogram, Full Statistics, Tuning Needle with min/max indicators and Data Logging

## AVAILABLE MODELS



THZ2.5B-BL  
(2.5 mm-Organic Black)



THZ5B-BL  
(5 mm-Organic Black)



THZ9B-BL  
(9 mm-Organic Black)

## ACCESSORIES



Stand with Delrin Post  
(Model Number: 200428)



Removable IR Windows  
(Various types available)



SDC-500 Digital  
Optical Chopper



T-Rad-Analog  
Analog Power Supply



Winston Cone



Pelican Carrying Case

## SEE ALSO

TECHNICAL DRAWINGS	<b>130</b>
ABSORPTION CURVES	<b>132</b>
LIST OF ALL ACCESSORIES	<b>184</b>

<b>APPLICATION NOTES</b>	
THZ MEASUREMENT: PYROELECTRIC VS GOLAY CELL	<a href="#">201924</a>
THZ CALIBRATION	<a href="#">202155</a>
THZ-WC-13: WINSTON CONE ACCESSORY	<a href="#">202172</a>
SDC-500 DIGITAL OPTICAL CHOPPER	<a href="#">202154</a>
THZ SETUP	<a href="#">202177</a>

Watch the demonstration video available on our website at [www.gentec-eo.com](http://www.gentec-eo.com)

MONITORS

ENERGY DETECTORS

POWER DETECTORS

HIGH POWER SOLUTIONS

PHOTO DETECTORS

THZ DETECTORS

OEM DETECTORS

SPECIAL PRODUCTS

BEAM DIAGNOSTICS

## THZ-B



Approved or in the process of being approved\*

## SPECIFICATIONS

	THZ2.5B-BL		THZ5B-BL		THZ9B-BL	
<b>MAX AVERAGE POWER</b>	2 mW		20 mW		20 mW	
<b>EFFECTIVE APERTURE</b>	2.5 mm Ø		5 mm Ø		9 mm Ø	
<b>COMPATIBLE MODULES</b>	T-Rad and T-Rad-Analog		T-Rad and T-Rad-Analog		T-Rad and T-Rad-Analog	
<b>MEASUREMENT CAPABILITY</b>	With T-Rad	With T-Rad-Analog	With T-Rad	With T-Rad-Analog	With T-Rad	With T-Rad-Analog
Spectral Range <sup>a</sup>						
Frequency	0.1 - 30 THz		0.1 - 30 THz		0.1 - 30 THz	
Wavelength	3000 - 10 µm		3000 - 10 µm		3000 - 10 µm	
Max Measurable Power	2 mW	7.5 µW	20 mW	43 µW	20 mW	150 µW
Noise Equivalent Power (NEP)	2 nW	2.0 x 10 <sup>-10</sup> W/(Hz) <sup>½</sup>	5 nW	1.0 x 10 <sup>-9</sup> W/(Hz) <sup>½</sup>	50 nW	3.0 x 10 <sup>-9</sup> W/(Hz) <sup>½</sup>
Rise Time (0-95%)	≤ 0.2s		≤ 0.2s		≤ 0.2s	
Sensitivity (Typical)	N/A	400 kV/W	N/A	70 kV/W	N/A	20 kV/W
Chopping Frequency <sup>b</sup>	25 Hz	5 Hz	25 Hz	5 Hz	25 Hz	5 Hz
<b>DAMAGE THRESHOLDS</b>	Max Average Power Density (@ 1064 nm)					
<b>PHYSICAL CHARACTERISTICS</b>						
Effective Aperture	2.5 mm Ø		5 mm Ø		9 mm Ø	
Sensor	Pyroelectric		Pyroelectric		Pyroelectric	
Absorber	BL		BL		BL	
Dimensions	66.0Ø x 46.5D mm		66.0Ø x 46.5D mm		66.0Ø x 46.5D mm	
Weight	227 g		227 g		227 g	
<b>ORDERING INFORMATION</b>	With T-Rad	With T-Rad-Analog	With T-Rad	With T-Rad-Analog	With T-Rad	With T-Rad-Analog
Product Name (including stand)	THZ2.5B-BL-DZ	THZ1.5B-BL-DA	THZ5B-BL-DZ	THZ5B-BL-DA	THZ9B-BL-DZ	THZ9B-BL-DA
Product Number	202912	202913	202299	202298	202301	202300
Modules	T-Rad: 201849 / T-Rad-Analog: 202306					

Specifications are subject to change without notice

- a. Projected Spectral Range.  
From 10 to 440 µm, spectrometer measurement.  
From 440 to 3000 µm, relative measurement only.  
This spectral range is subject to change.
- b. SDC-500 Digital Optical Chopper sold separately.

# THZ-B

MONITORS

ENERGY DETECTORS

POWER DETECTORS

HIGH POWER SOLUTIONS

PHOTO DETECTORS

THZ DETECTORS

OEM DETECTORS

SPECIAL PRODUCTS

BEAM DIAGNOSTICS



T-Rad  
(Front View)



T-Rad  
(Rear View)



## T-Rad

The T-Rad is a microprocessor-based digital radiometer that includes a 12-bit ADC and unique DSP Lock-In Software. It is powered by a USB connection, which also acts as a Virtual COM port. When a THZ-B Terahertz Pyroelectric detector is plugged into the T-Rad module, the module reads the content of the head's EEPROM, which identifies the detector and provides calibration and wavelength correction data. The LabView Software supplied with the device makes it very easy to set up the radiometer, measure a THz or broadband source and record data. The software is compatible with Windows XP, VISTA and 7.

## SPECIFICATIONS & FEATURES

### T-Rad

<b>Compatible Detector Heads</b>	THZ-B-DZ
<b>Full Scale Ranges</b>	200 nW - 200 mW *
<b>Power On Light</b>	Green
<b>Detector Input</b>	DB-15
<b>Analog Output</b>	BNC Connector - 0 to 3.6 V
<b>Computer Connection</b>	USB (Virtual COM Port)
<b>Trigger Input (TTL)</b>	BNC Connector
<b>Product Number</b>	201849

\* Actual ranges vary based on the THZ-B detector selected

## INSTRUMENT CONTROL AND STRIP CHART

Instrument controls and the radiant power measurement are always visible, making it easy to change the radiometer settings, no matter which display tab is selected. Instrument controls include: Range, Filter Tau, Batch Size, Data Collection Mode, Reset Options, and a Null button for background cancellation. In addition, there are more set up and operation status indicators including: detector Rv, Wavelength, Frequency (actual), Locked and Frequency in Range lights. The Strip Chart displays the Radiant Power measurement in Watts, either continuously or by the batch. Select full scale, auto scale or use our manual scaling option.

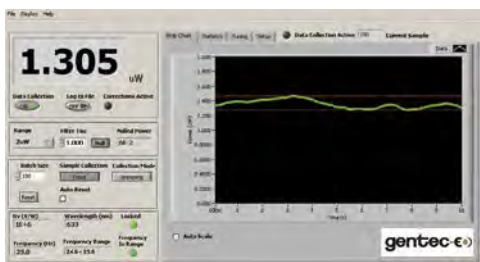

## INSTRUMENT CONTROL AND TUNING NEEDLE

The "TUNE" tab selects the very useful "Tuning Needle" display. This is a simulated analog meter whose speed is determined by the "filter tau" setting. It is expected to be used during the set-up of a radiometer with a source. The "tau" value is usually set to a small value when aligning the probe to the source (i.e. when peaking the reading). There is a button control to select "full scale", "min-max" or "reset". In the "min-max" mode, the indicators are "blue" for the minimum power and "red" for the maximum power.



# THZ-B



## INSTRUMENT CONTROL AND STATISTICS

In the "Statistics" tab there are 4 large windows that contain the statistics for the selected batch, including: Minimum, Maximum, Standard Deviation and Mean, expressed in Engineering Notation. Standard Deviation can be displayed in Watts or as a % that is user-selectable. There is also a window that shows the bandwidth of the Digital Band Pass Filter based on the user selected "Filter Tau" (0.100 to 100 seconds). A lower time constant is helpful when setting up, and a longer one when making measurements, especially on the lower ranges of the instrument.

## THZ-B-DA DETECTOR AND OSCILLOSCOPE

Here is a basic analog set up that would be useful if the optical power of the source was about  $5 \mu\text{W}$  or greater. The output of the THZ5B-BL-DA detector would be approximately  $600 \text{ mV} @ 5 \text{ Hz}$  chopping frequency, giving plenty of signal for an oscilloscope. Simply read the voltage output and divide by the  $R_v$  factor (V/W) of the detector to measure the intensity of the source in Watts. Also consider applying a wavelength correction factor under certain circumstances.

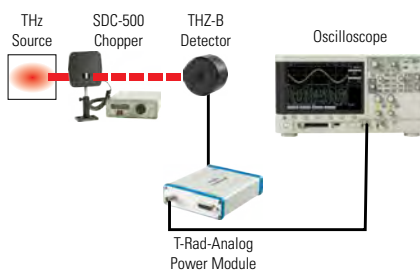

## THZ-B-DA DETECTOR AND LOCK-IN AMPLIFIER

This is another analog set-up option that we recommend if you have to measure very low power levels (i.e. less than  $5 \mu\text{W}$ ) where the signal may be buried in the broadband noise. The voltage output of the analog THZ-B-DA detector, powered by our T-Rad-Analog, is routed to the Lock-In Amplifier input, and the Sync Output of our SDC-500 Chopper is connected to the reference input. The Lock-In Amplifier will lock on the chopping frequency and you can dial in a long integrating time and measure a very low RMS voltage. The voltage divided by our Voltage Responsivity (V/W) equals the power of the source.

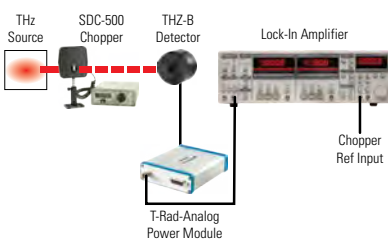

## THZ-B-DZ DETECTOR AND T-Rad MODULE

Although analog solutions are available, for simplicity, convenience and sensitivity, we recommend you choose our THZ-B-DZ detectors and the T-Rad Digital Radiometer. Our unique DSP Lock-In Amplifier software provides a function much like the Analog Lock-In, but is so much easier to use. It also addresses thermal drift of the sensor and allows you to display the power measurement and complete statistics directly in digital and graphic formats. Set the range, null the background, set the filter tau (bandwidth) and make the measurement. It's that easy!

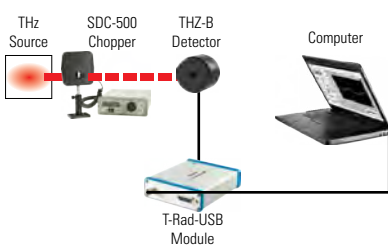

# QS-THZ

Hybrid THz Detectors

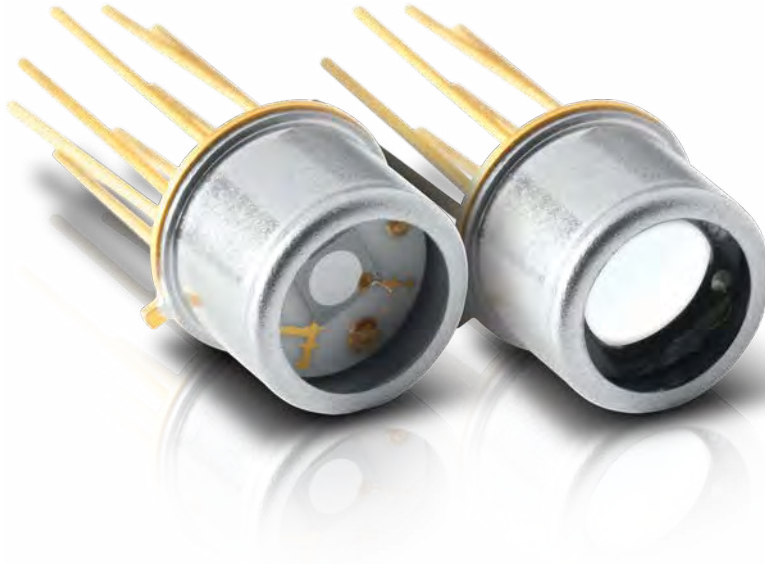

\* Pictures for indicative purposes only

## AVAILABLE MODELS

- QS2-THZ-BL 2 x 2 mm, Pyroelectric Sensor with Organic Black Coating in T05 Packaging
- QS5-THZ-BL 5 mm Ø, Pyroelectric Sensor with Organic Black Coating in T05 Packaging
- QS9-THZ-BL 9 mm Ø, Pyroelectric Sensor with Organic Black Coating in T08 Packaging

## ACCESSORIES



QS-I-Test  
Evaluation Test Box



Permanent IR Windows  
(Various types available)



SDC-500 Digital  
Optical Chopper



Pelican Carrying Case

## KEY FEATURES

- 1. RELATIVE MEASUREMENTS FROM 0.1 TO 30 THz**  
Broadband, room temperature operation, easier to use and less expensive than a Golay cell
- 2. EASY TO INTEGRATE FORMAT**  
T05 and T08 packages make the QS-THZ detectors small and easy to integrate in an existing system
- 3. SEVERAL SENSOR SIZES AVAILABLE**  
Choice of 2 x 2 mm, 5 and 9 mm Ø
- 4. CALIBRATED AT 0.63 µm**  
All THz detectors are calibrated at a single wavelength (0.63 µm) and include a typical wavelength correction data from 0.25 to 440 µm. They are used for relative measurements outside that range.
- 5. TEST BOX AVAILABLE**  
Can be used with our QS-I-TEST test box which provides mounting and power supply
- 6. PERMANENT IR WINDOW OPTIONS**  
Every model can be fitted with a permanent IR window to narrow the wavelength range:  
S5/8: Sapphire (0.3 – 4.5 and 100 - 1000 µm)  
Q5/8: Quartz (0.25 – 3.0 and 50 - 1000 µm)  
Si5/8: Silicon (1.2 – 8.0 and 50 - 1000 µm)

## SEE ALSO

TECHNICAL DRAWINGS **130**  
LIST OF ALL ACCESSORIES **184**

APPLICATION NOTES  
THZ MEASUREMENT:  
PYROELECTRIC VS GOLAY CELL [201924](#)

QS-I-TEST SPECIFICATIONS [202187](#)

# QS-THZ



Approved or in the process of being approved\*

## SPECIFICATIONS

	QS2-THZ-BL	QS5-THZ-BL	QS9-THZ-BL
<b>VOLTAGE RESPONSIVITY</b>	140 kV/W	70 kV/W	30 kV/W
<b>EFFECTIVE APERTURE</b>	2 x 2 mm	5 mm Ø	9 mm Ø
<b>PACKAGE</b>	T05	T05	T08
<b>MEASUREMENT CAPABILITY</b>			
Spectral Range <sup>a</sup>			
Frequency	0.1 - 30 THz	0.1 - 30 THz	0.1 - 30 THz
Wavelength	3000 - 10 µm	3000 - 10 µm	3000 - 10 µm
Max Power Density	50 mW/cm <sup>2</sup>	50 mW/cm <sup>2</sup>	50 mW/cm <sup>2</sup>
Noise Equivalent Power	4.0 x 10 <sup>-10</sup> W/(Hz) <sup>½</sup>	1.0 x 10 <sup>-9</sup> W/(Hz) <sup>½</sup>	3.0 x 10 <sup>-9</sup> W/(Hz) <sup>½</sup>
Detectivity <sup>b</sup>	5.10 <sup>9</sup> cm(Hz) <sup>½</sup> /W	4.10 <sup>9</sup> cm(Hz) <sup>½</sup> /W	2.7.10 <sup>9</sup> cm(Hz) <sup>½</sup> /W
Voltage Responsivity <sup>b</sup>	140 kV/W	70 kV/W	30 kV/W
<b>PHYSICAL CHARACTERISTICS</b>			
Effective Aperture	2 x 2 mm	5 mm Ø	9 mm Ø
Package	T05	T05	T08
Sensor	Pyroelectric	Pyroelectric	Pyroelectric
Absorber	BL	BL	BL
Dimensions	3.6Ø x 7.5D mm	3.6Ø x 7.5D mm	3.6Ø x 7.5D mm
Weight	45 g	45 g	45 g
<b>ORDERING INFORMATION</b>			
Product Name	QS2-THZ-BL	QS5-THZ-BL	QS9-THZ-BL
Product Number	201691	202289	201690

Specifications are subject to change without notice

- a. Projected Spectral Range.  
 From 10 to 440 µm, spectrometer measurement.  
 From 440 to 3000 µm, relative measurement only.  
 This spectral range is subject to change.
- b. 630 nm, 5 Hz



## QS-I-TEST EVALUATION TEST BOX

QS-I-TEST	
Batteries	+9V/-9V
R <sub>i</sub> Resistors	10 <sup>5</sup> - 10 <sup>10</sup> Ω
C <sub>i</sub> Compensating	YES
Package	101.6H x 127W x 58.4D
Optical Mount	¼-20 Threaded
Front Bezel	SM1 (1.035-40)
Product Number	201693

\* For details, contact your Gentec-EO representative

# TECHNICAL DRAWINGS

All dimensions in mm

## THZ12D-3S-VP

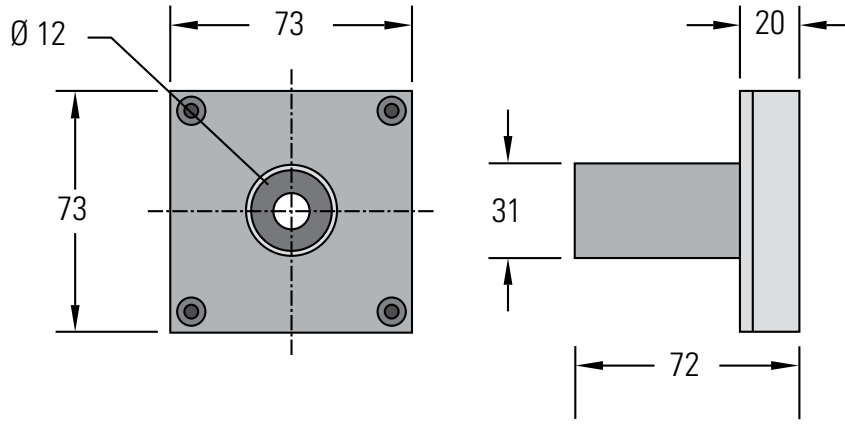

View

FRONT

SIDE

## THZ9D-20mS-BL

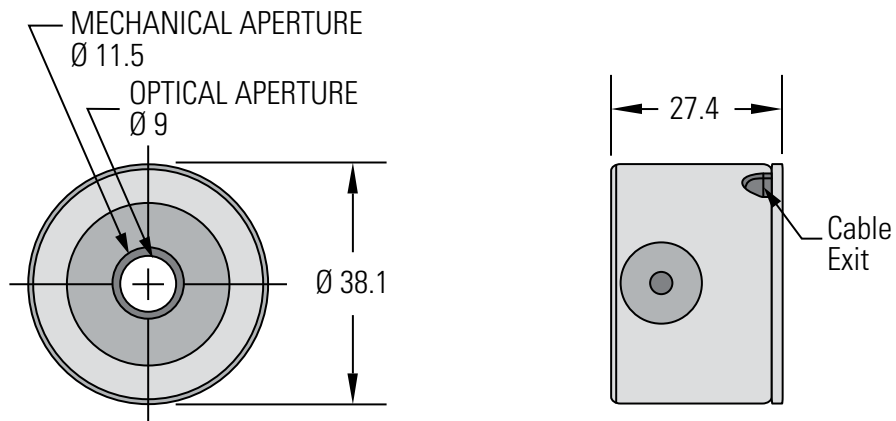

View

FRONT

SIDE

## THZ-I-BNC

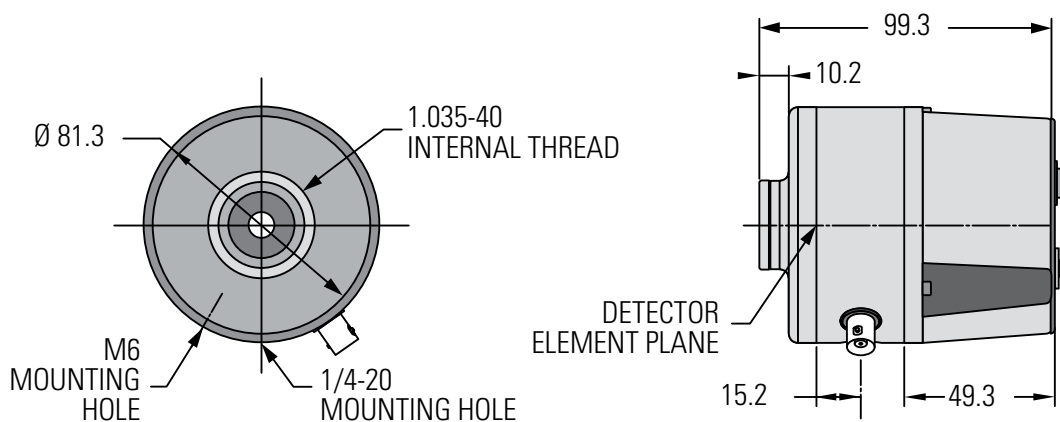

View

FRONT

SIDE

MONITORS  
ENERGY DETECTORS  
POWER DETECTORS  
HIGH-POWER SOLUTIONS  
PHOTO DETECTORS  
THZ DETECTORS  
OEM DETECTORS  
SPECIAL PRODUCTS  
BEAM DIAGNOSTICS

# TECHNICAL DRAWINGS

All dimensions in mm

## THZ-B

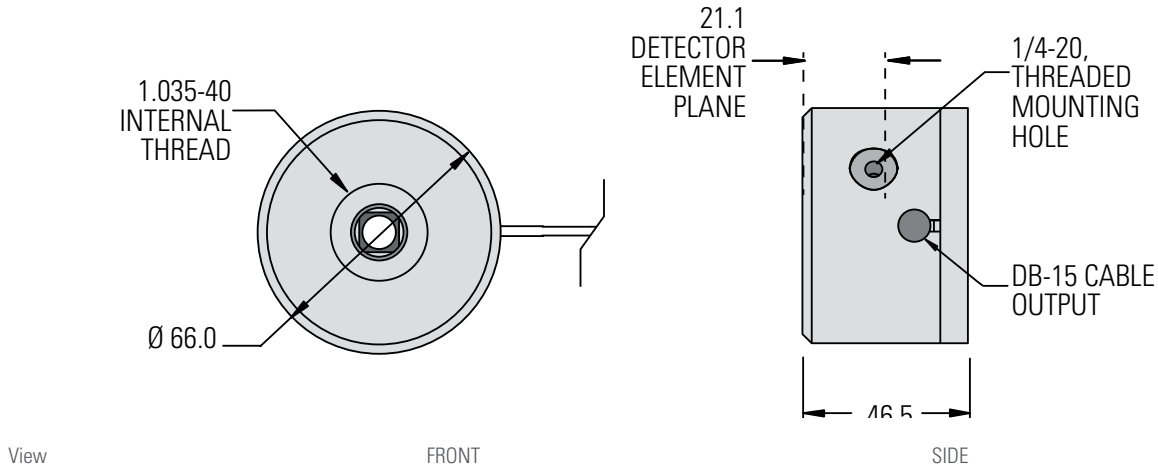

## QS-THZ (TO5-BASED)

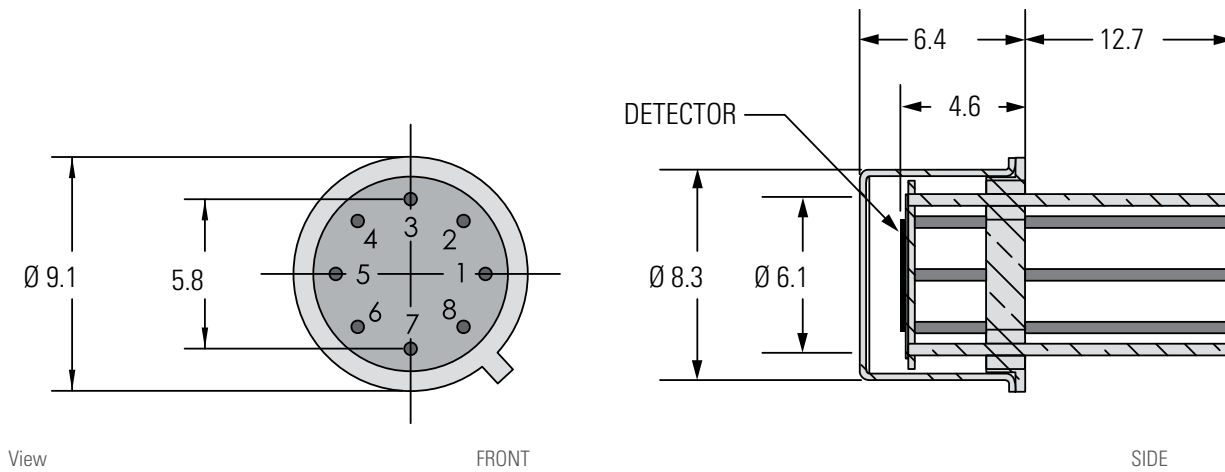

## QS-THZ (TO8-BASED)

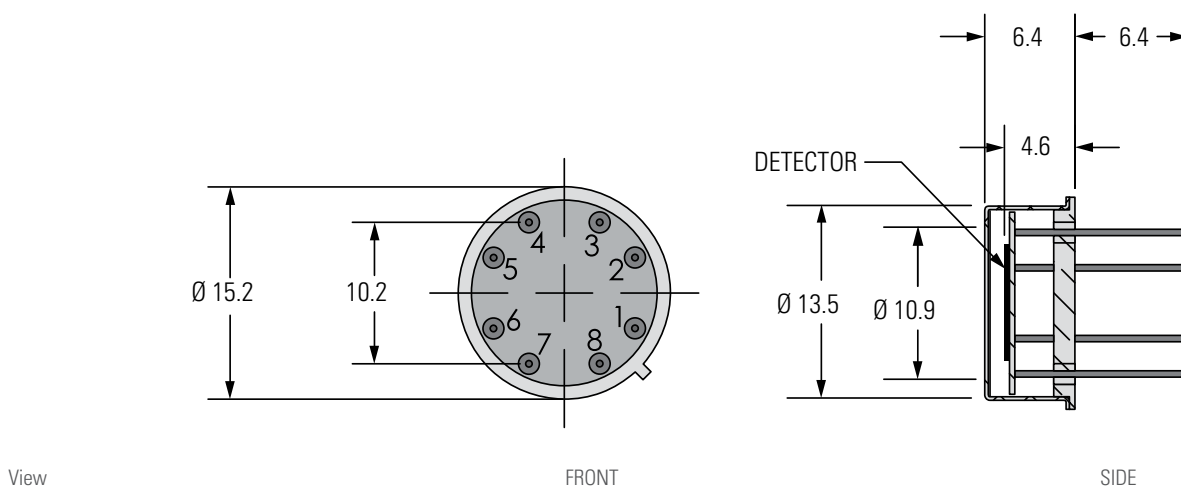

MONITORS

ENERGY DETECTORS

POWER DETECTORS

HIGH POWER SOLUTIONS

PHOTO DETECTORS

THZ DETECTORS

OEM DETECTORS

SPECIAL PRODUCTS

BEAM DIAGNOSTICS

# ABSORPTION CURVES

THZ12D-3S-VP

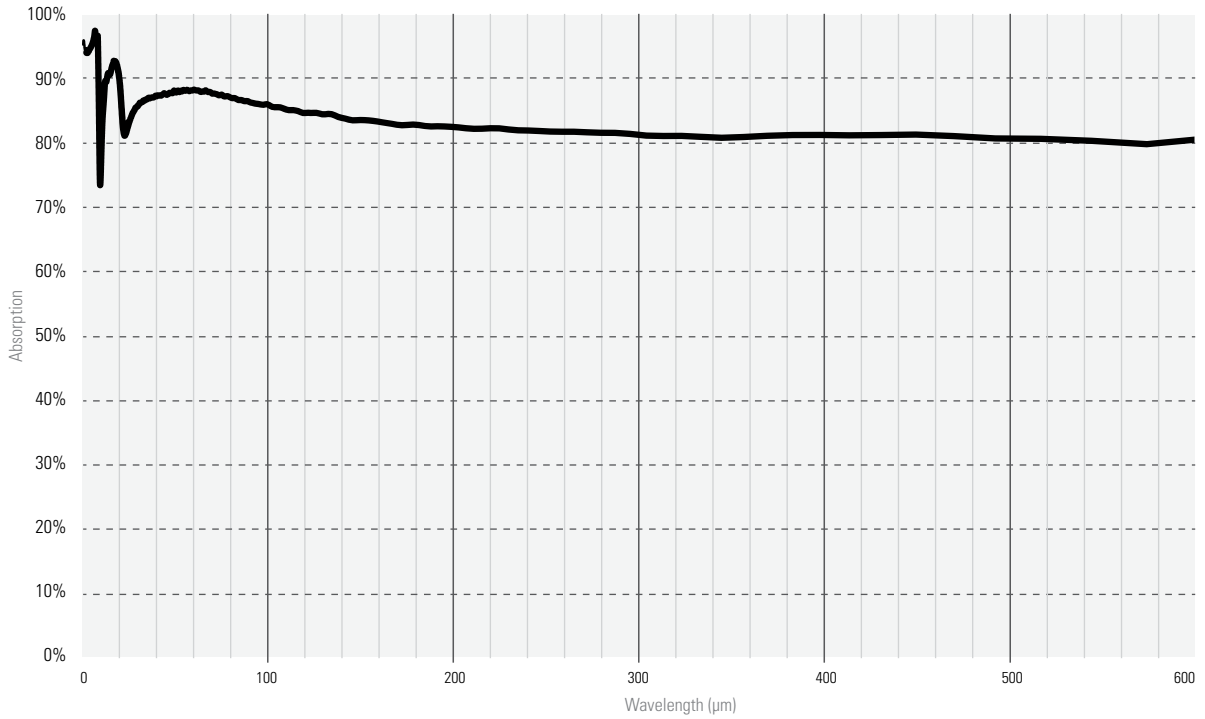

- MONITORS
- ENERGY DETECTORS
- POWER DETECTORS
- HIGH POWER SOLUTIONS
- PHOTO DETECTORS
- THZ DETECTORS
- OEM DETECTORS
- SPECIAL PRODUCTS
- BEAM DIAGNOSTICS

# ABSORPTION CURVES

THZ-BL

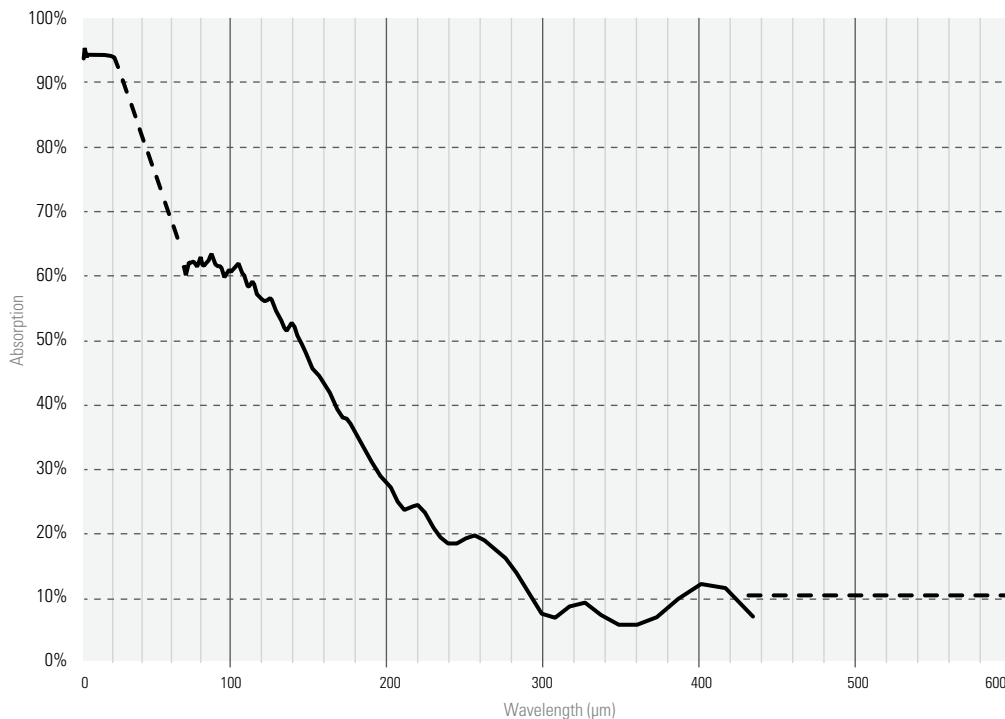

MONITORS

ENERGY DETECTORS

POWER DETECTORS

HIGH POWER SOLUTIONS

PHOTO DETECTORS

THZ DETECTORS

OEM DETECTORS

SPECIAL PRODUCTS

BEAM DIAGNOSTICS

# PRESENTATION

## OVERVIEW OF THE DIFFERENT MODELS

The Gentec-EO monitors come in various sizes and types to cover all applications. We have monitors with or without display (PC-based) and for power or energy readings, or both. We also offer the fastest digital needle display on the market.

MONITORS

ENERGY DETECTORS

POWER DETECTORS

HIGH POWER SOLUTIONS

PHOTO DETECTORS

THZ DETECTORS

OEM DETECTORS

SPECIAL PRODUCTS

BEAM DIAGNOSTICS



## COMPACTNESS

As an OEM, we know space is often a constraint. This is why we offer very compact detectors to ease the integration inside machines. We have built our expertise on detector compactness on our exclusive modular design. Users can mix and match existing detectors and cooling modules from a large set of combinations, thus obtaining the smallest detector possible.

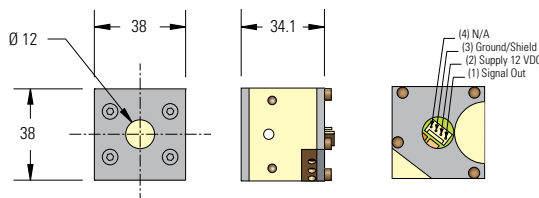

## PERFORMANCE

If you select an Ultra Disk (UD Series), you can use our external PCB for signal anticipation, amplification and filtering. We can also integrate a PCB inside complete detectors. See the UP SERIES WITH PCB (Page 140) for details.

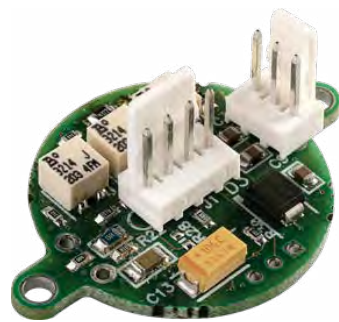

### ANTICIPATION

0-95% of the signal in as quickly as 0.3 sec with the small UD12-70-H5 and in 0.6 sec with the UD19-200-H5 using our external PCB.

### AMPLIFICATION

Adjust your disk sensitivity to get the perfect voltage for your acquisition system. Disks can be adjusted from 0.6 to 2 V/W.

### FILTERING

Eliminate the high frequency noise coming from the environment with the integrated low-pass filter of our PCB.

## CONNECTIVITY

Gentec-EO offers you several types of output connectors, from the more standard DB-15, BNC and Molex to any exotic type you may need.



### DB-15

This connector contains an EEPROM with custom calibration data for both Power and Energy Detectors.

### BNC

The BNC output gives you fast, easy installation and the best EMI noise shielding. Perfect for the sensitive Energy Detectors.

### MOLEX

With the Molex connector and pigtail, you join the power and signal wires of the pigtail to your system. Easy to unplug for service.

# PRESENTATION

## OVERVIEW OF THE DIFFERENT MODELS

Almost anything you see in our product line can be turned into an OEM unit! We also offer standard OEM products, at different levels of integration: from the simple thermopile disk to a complete head with internal PCB for signal anticipation and amplification.



### UD SERIES

- Thermal Sensor Disks
- Designed for Integration
- Many Sizes and Absorber Choices:
  - 10, 12, 19, 25, and 55 mm Ø Apertures
  - Broadband or High Damage Threshold Coatings

#### ■ THERMAL SENSOR DISKS

See page **136**



### UP SERIES

- Complete Thermal Heads with Cooling Modules
- Several Sizes, Coolings and Absorber Choices:
  - 10, 12, 19, 25, 50 and 55 mm Ø Apertures
  - Broadband or High Damage Threshold Coatings
  - Convection, Fan or Water-Cooled
- BNC, Molex or DB-15 Connectors

#### ■ THERMAL SENSOR HEADS

See page **138**



### UP SERIES WITH PCB

- Complete Thermal Heads with Cooling Modules
- Internal PCB for Amplification, Anticipation and Filtering
- Several Sizes, Coolings and Absorber Choices:
  - 10, 12, 19, 25, 50 and 55 mm Ø Apertures
  - Broadband or High Damage Threshold Coatings
  - Convection, Fan or Water-Cooled
- BNC, Molex or DB-15 Connectors

#### ■ THERMAL SENSOR HEADS WITH PCB

See page **140**

# UD SERIES

Thermal Sensor Disks, 10 - 55 mm Ø, 200 µm - 500 W



## KEY FEATURES

1. **DESIGNED FOR INTEGRATION**  
With a broad bandwidth and high power densities
2. **VERY THIN PROFILES**  
Starting at only 2 mm deep
3. **VARIOUS APERTURE SIZES**  
Choose your aperture from 10 mm Ø to 55 mm Ø
4. **2 LEVELS OF INTEGRATION**
  - Disk alone
  - Disk + PCB

## AVAILABLE MODELS

NEW



UD10-2-H5-L  
(10 mm-2 W)



UD12-70-H5  
(12 mm-70 W)



UD19-150-H5  
(19 mm-150 W)



UD19-200-H9  
(19 mm-200 W)



UD25-300-H9/H12  
(25 mm-350 W)



UD55-400-H9/H12  
(55 mm-500 W)



UD19-50-W5  
(19 mm-100 kW/cm<sup>2</sup>)

## HOW TO USE SENSOR DISKS

The Ultra Disks were designed for integration into laser systems. They are the solution if you are engineering the cooling and signal processing into your system already.

The chart below and on the next page show the various Possibilities that Gentec-EO offers to OEM users. The choice of a level of integration depends on your needs in terms of calibration, output signal level, cooling availability, etc.

1



Disk Alone  
Thermal Sensor Disk

2

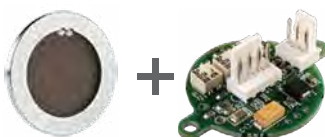

Disk + PCB  
 • Thermal Sensor Disk  
 • Amplification - Anticipation - Filtering

## SEE ALSO

- HOW IT WORKS** 14
- ABSORPTION CURVES** 92
- LIST OF ALL ACCESSORIES** 184

MONITORS

ENERGY DETECTORS

POWER DETECTORS

HIGH POWER SOLUTIONS

PHOTO DETECTORS

THZ DETECTORS

OEM DETECTORS

SPECIAL PRODUCTS

BEAM DIAGNOSTICS

## UD SERIES



## SPECIFICATIONS

	NEW UD10-2-H5-L	UD12-70-H5	UD19-150-H5	UD19-200-H9	UD25-300-H9(H12)	UD55-400-H9(H12)	UD19-50-W5
<b>MAX AVERAGE POWER (CONTINUOUS / 1 MINUTE)</b>	2 W / 2 W	70 W / 110 W	150 W / 190 W	200 W / 200 W	300 W / 300 W (350 W / 350 W)	400 W / 400 W (500 W / 500 W)	50 W / 85 W
<b>EFFECTIVE APERTURE</b>	10 mm Ø	12 mm Ø	19 mm Ø	19 mm Ø	25 mm Ø	55 mm Ø	17 mm Ø
<b>MEASUREMENT CAPABILITY</b>							
Spectral Range	0.19 – 20 µm	0.19 – 20 µm	0.19 – 20 µm	0.19 – 20 µm	0.19 – 20 µm	0.19 – 20 µm	0.19 – 10 µm
Noise Equivalent Power	0.2 mW	1 mW	1 mW	3 mW	3 mW (10 mW)	5 mW (15 mW)	1 mW
Rise Time (nominal) <sup>a, b</sup>	2.7 sec	1.6 sec	2.8 sec	4.5 sec	5 sec (7.9 sec)	11 sec (18 sec)	5 sec
Sensitivity (typ into 100 kΩ load) <sup>b</sup>	2 mV/W	0.53 mV/W	0.65 mV/W	0.23 mV/W	0.23 mV/W (0.1 mV/W)	0.12 mV/W (0.06 mV/W)	0.65 mV/W
<b>Energy Mode</b>							
Sensitivity	---	0.84 mV/J	0.65 mV/J	0.23 mV/J	0.14 mV/J (0.05 mV/J)	0.028 mV/J (0.015 mV/J)	0.33 mV/J
Maximum Measurable Energy <sup>c</sup>	---	5 J	15 J	25 J	40 J	200 J	200 J
Noise Equivalent Energy <sup>a</sup>	---	20 mJ	20 mJ	60 mJ	200 mJ	250 mJ	23 mJ
<b>DAMAGE THRESHOLDS</b>							
Maximum Average Power Density	36 kW/cm <sup>2</sup>	36 kW/cm <sup>2</sup>	36 kW/cm <sup>2</sup>	45 kW/cm <sup>2</sup>	45 kW/cm <sup>2</sup>	45 kW/cm <sup>2</sup>	100 kW/cm <sup>2</sup>
<b>Pulsed Laser Damage Thresholds</b>							
1064 nm, 360 µs, 5 Hz	5 J/cm <sup>2</sup>	5 J/cm <sup>2</sup>	5 J/cm <sup>2</sup>	9 J/cm <sup>2</sup>	9 J/cm <sup>2</sup>	9 J/cm <sup>2</sup>	100 J/cm <sup>2</sup>
1064 nm, 7 ns, 10 Hz	1 J/cm <sup>2</sup>	1 J/cm <sup>2</sup>	1 J/cm <sup>2</sup>	1 J/cm <sup>2</sup>	1 J/cm <sup>2</sup>	1 J/cm <sup>2</sup>	1.1 J/cm <sup>2</sup>
532 nm, 7 ns, 10 Hz	0.6 J/cm <sup>2</sup>	0.6 J/cm <sup>2</sup>	0.6 J/cm <sup>2</sup>	0.6 J/cm <sup>2</sup>	0.6 J/cm <sup>2</sup>	0.6 J/cm <sup>2</sup>	1.1 J/cm <sup>2</sup>
266 nm, 7 ns, 10 Hz	0.3 J/cm <sup>2</sup>	0.3 J/cm <sup>2</sup>	0.3 J/cm <sup>2</sup>	0.3 J/cm <sup>2</sup>	0.3 J/cm <sup>2</sup>	0.3 J/cm <sup>2</sup>	0.7 J/cm <sup>2</sup>
<b>PHYSICAL CHARACTERISTICS</b>							
Absorber	H5	H5	H5	H9	H9(H12)	H9(H12)	W5
Dimensions	44Ø x 4D mm	36Ø x 2D mm	44Ø x 3P mm	44Ø x 3D mm	54Ø x 3D mm	85Ø x 4D mm	44Ø x 3D mm
Weight (head only)	7 g	4 g	7 g	7 g	13 g	39 g	7 g
<b>ORDERING INFORMATION</b>							
Product Name	UD10-2-H5-L	UD12-70-H5	UD19-150-H5	UD19-200-H9	UD25-300-H9	UD55-400-H9	UD19-50-W5
Product Number	202832	200382	200262	200576	200263	200264	200761
Product Name					UD25-350-H12	UD55-500-H12	
Product Number					202378	201220	

Specifications are subject to change without notice

- a. These characteristics depend on the thermal management and electronics provided by the user. Packaging, cooling and electronics similar to our Ultra Series (UP) detectors will provide similar performances. See UP Series specifications sheets for more details. Actual performance depends on the tradeoffs in a user's design. It may be possible to enhance some performance parameters at the expense of others.
- b. Without anticipation algorithm or circuitry.
- c. For 360 µs pulses. Higher pulse energy possible when customized for long pulses (ms), less for short pulses (ns).

# UP SERIES

Thermal Sensor Heads, 10 - 55 mm Ø, 50 µm - 700 W



## KEY FEATURES



- FULLY INTEGRABLE THERMOPILE SENSOR HEADS**  
OEM Sensors designed to integrate easily into existing systems
- MODULAR CONCEPT**  
Increase the power capability of your detector:  
5 different cooling modules
- VERY HIGH DAMAGE THRESHOLDS**  
Up to 100 kW/cm<sup>2</sup> in average power density
- CHOICE OF CONNECTORS**  
DB-15, BNC, Molex

## AVAILABLE MODELS

NEW



## LEVELS OF INTEGRATION

- 
  - Head Only
  - Thermal Sensor Head (with natural response)
  - Connector
- 
  - Head with PCB & Connector
  - Thermal Sensor Head
  - Amplification - Anticipation - Filtering
  - Connector
- 
  - Head & Display
  - Thermal Sensor Head
  - Connector
  - Display

## SEE ALSO

HOW IT WORKS	14
CALIBRATION	6
TECHNICAL DRAWINGS	88
ABSORPTION CURVES	92
COMPATIBLE MONITORS	
MAESTRO	20
TUNER	24
UNO	26
S-LINK	28
P-LINK	30
M-LINK	32
LIST OF ALL ACCESSORIES	184

# UP SERIES



\*Also traceable to NRC-CNRC

## SPECIFICATIONS

	NEW UP10-H	UP12-H	UP19-H	UP25-H	UP55-H/HD	UP19-W	UP50-W
<b>MAX AVERAGE POWER<sup>a</sup> (CONTINUOUS / 1 MINUTE)</b>	2 W / 2 W	70 W / 110 W	200 W / 200 W	350 W / 350 W	700 W / 700 W	50 W / 85 W	50 W / 85 W
<b>EFFECTIVE APERTURE</b>	10 mm Ø	12 mm Ø	19 mm Ø	25 mm Ø	55 mm Ø	17 mm Ø	50 mm Ø

MEASUREMENT CAPABILITY							
Spectral Range	0.19 – 20 µm	0.19 – 20 µm	0.19 – 20 µm	0.19 – 20 µm	0.19 – 20 µm	0.19 – 10 µm	0.19 – 10 µm
Available Cooling Modules (Max. Power)							
Standalone (S)	2 W	10 W	15 W	40 W	40 W	15 W	40 W
Heatsink (H)	---	20 W	30 W	100 W	100 W	30 W	50 W
Large Heatsink (L)	---	---	50 W	---	---	50 W	---
Fan (F)	---	---	110 W	250 W	300 W	50 W	50 W
Water (W)	---	70 W	150 W	350 W	500 W	50 W	50 W
Water (W)	---	---	200 W	---	700 W (HD)	---	---
Noise Equivalent Power	0.05 mW <sup>b</sup>	1 mW	1-3 mW	3-10 mW	5-45 mW	1 mW	5 mW
Rise Time (nominal)	2.7 sec	1.6 sec	2.8-4.5 sec	5-7.9 sec	11-18 sec	5 sec	16 sec
Sensitivity (typ into 10 MΩ load)	2 mV/W	0.53 mV/W	0.23-0.65 mV/W	0.1-0.23 mV/W	0.03-0.12 mV/W	0.65 mV/W	0.12 mV/W
Maximum Average Power Density <sup>b</sup>	36 kW/cm <sup>2</sup>	36 kW/cm <sup>2</sup>	36-45 kW/cm <sup>2</sup>	45 kW/cm <sup>2</sup>	45 kW/cm <sup>2</sup>	100 kW/cm <sup>2</sup>	100 kW/cm <sup>2</sup>

PHYSICAL CHARACTERISTICS							
Effective Aperture	10 mm Ø	12 mm Ø	19 mm Ø	25 mm Ø	55 mm Ø	17 mm Ø	50 mm Ø
Absorber	H5	H5	H5/H9	H9/H12	H9/H12/HD	W5	W9
Dimensions <sup>c</sup>	50H x 50W x 20.6D mm	38H x 38W x 14D mm	50H x 50W x 20.6D mm	89H x 89W x 32D mm	89H x 89W x 32D mm	50H x 50W x 20.6D mm	89H x 89W x 32D mm
Weight <sup>c</sup>	160 g	130 g	160 g	680 g	620 g	160 g	620 g

ORDERING INFORMATION							
Standalone	UP10K-2S-H5-L-DO	UP12E-10S-H5-DO	UP19K-15S-H5-DO	UP25N-40S-H9-DO	UP55N-40S-H9-DO	UP19K-15S-W5-DO	UP50N-40S-W9-DO
Heatsink	---	UP12E-20H-H5-DO	UP19K-30H-H5-DO	UP25N-100H-H9-DO	UP55N-100H-H9-DO	UP19K-30H-W5-DO	UP50N-50H-W9-DO
Large Heatsink	---	---	UP19K-50L-H5-DO	---	---	UP19K-50L-W5-DO	---
Fan-Cooled	---	---	UP19K-110F-H9-DO	UP25N-250F-H12-DO	UP55N-300F-H12-DO	UP19K-50F-W5-DO	UP50N-50F-W9-DO
Water-Cooled	---	UP12E-70W-H5-DO	UP19K-150W-H5-DO	UP25M-350W-H12-DO	UP55M-500W-H12-DO	UP19K-50W-W5-DO	UP50M-50W-W9-DO
	---	---	UP19K-200W-H9-DO	---	UP55M-700W-HD-DO	---	---

Specifications are subject to change without notice

- a. For model with the most efficient cooling module available.  
 b. 0.2 mW with anticipation.  
 c. At 1064 nm, 10 W CW.  
 d. For standalone version. Ask gentec-E0 for dimensions of other versions.

# UP SERIES + PCB

Thermal Sensor Heads with Internal PCB, 10 - 55 mm Ø, 50 µm - 700 W



## KEY FEATURES

- FULLY INTEGRABLE THERMOPILE SENSOR HEADS**  
OEM Sensors designed to integrate easily into existing systems
- WITH INTERNAL PCB**  
Integrated amplification, anticipation and filtering
- MODULAR CONCEPT**  
Increase the power capability of your detector : 5 different cooling modules
- VERY HIGH DAMAGE THRESHOLDS**  
Up to 100 kW/cm<sup>2</sup> in average power density
- LARGEST CHOICE OF CONNECTORS**  
DB-15, BNC, Molex or custom

## AVAILABLE MODELS



- UP10-H 10 mm Ø, 12 W, Standard Broadband Coating (H5), 50 µm Noise Level
- UP12-H 12 mm Ø, 10 W, With Rear Molex Output
- UP19-H 19 mm Ø, 15-30-50-110-150-200 W, Standard Broadband Coating (H5 or H9)
- UP25-H 25 mm Ø, 40-100-250-350 W, Standard Broadband Coating (H9 or H12)
- UP55-H/HD 55 mm Ø, 40-100-300-500-700 W, Standard Broadband Coating (H9/H12 or HD)
- UP19-W 17 mm Ø, 15-30-50 W, High Damage Threshold 100 kW/cm<sup>2</sup> Coating (W5)
- UP50-W 50 mm Ø, 40-50 W, High Damage Threshold 100 kW/cm<sup>2</sup> Coating (W9)

## LEVELS OF INTEGRATION

- 

**Head Only**

  - Thermal Sensor Head (with natural response)
  - Connector
- 

**Head with PCB & Connector**

  - Thermal Sensor Head
  - Amplification - Anticipation - Filtering
  - Connector
- 

**Head & Display**

  - Thermal Sensor Head
  - Connector
  - Display

## SEE ALSO

HOW IT WORKS	14
CALIBRATION	6
TECHNICAL DRAWINGS	88
ABSORPTION CURVES	92
COMPATIBLE MONITORS	
MAESTRO	20
TUNER	24
UNO	26
S-LINK	28
P-LINK	30
M-LINK	32
LIST OF ALL ACCESSORIES	184

MONITORS

ENERGY DETECTORS

POWER DETECTORS

HIGH POWER SOLUTIONS

PHOTO DETECTORS

THZ DETECTORS

OEM DETECTORS

SPECIAL PRODUCTS

BEAM DIAGNOSTICS

## UP SERIES + PCB



\*Also traceable to NRC-CNRC

## SPECIFICATIONS

	NEW UP10-H	UP12-H	UP19-H	UP25-H	UP55-H/HD	UP19-W	UP50-W
<b>MAX AVERAGE POWER<sup>a</sup> (CONTINUOUS / 1 MINUTE)</b>	2 W / 2 W	10 W / 10 W	200 W / 200 W	350 W / 350 W	700 W / 700 W	50 W / 85 W	50 W / 85 W
<b>EFFECTIVE APERTURE</b>	10 mm Ø	12 mm Ø	19 mm Ø	25 mm Ø	55 mm Ø	17 mm Ø	50 mm Ø
<b>MEASUREMENT CAPABILITY</b>							
Spectral Range	0.19 – 20 µm	0.19 – 20 µm	0.19 – 20 µm	0.19 – 20 µm	0.19 – 20 µm	0.19 – 10 µm	0.19 – 10 µm
Available Cooling Modules (Max. Power)							
Standalone (S)	2 W	10 W	15 W	40 W	40 W	15 W	40 W
Heatsink (H)	---	---	30 W	100 W	100 W	30 W	50 W
Large Heatsink (L)	---	---	50 W	---	---	50 W	---
Fan (F)	---	---	110 W	250 W	300 W	50 W	---
Water (W)	---	---	150 W	350 W	500 W	50 W	85 W
Water (W)	---	---	200 W	---	700 W (HD)	---	---
Noise Equivalent Power	0.05 mW <sup>b</sup>	0.2 mW	0.2 mW	1-10 mW	2-45 mW	0.2 mW	3 mW
Rise Time (anticipated)	0.8 sec	0.3 sec	0.5 sec	1.3 sec	2-5 sec	1.4 sec	3.5 sec
Sensitivity (typ into 10 MΩ load)	1 V/W	400 mV/W	30-400 mV/W	24-150 mV/W	8-150 mV/W	400 mV/W	120-150 mV/W
Maximum Average Power Density <sup>c</sup>	36 kW/cm <sup>2</sup>	36 kW/cm <sup>2</sup>	36-45 kW/cm <sup>2</sup>	45 kW/cm <sup>2</sup>	45 kW/cm <sup>2</sup>	100 kW/cm <sup>2</sup>	100 kW/cm <sup>2</sup>
<b>PHYSICAL CHARACTERISTICS</b>							
Effective Aperture	10 mm Ø	12 mm Ø	19 mm Ø	25 mm Ø	55 mm Ø	17 mm Ø	50 mm Ø
Absorber	H5	H5	H5/H9	H9/H12	H9/H12/HD	W5	W9
Dimensions <sup>d</sup>	50H x 50W x 25.6D mm	38H x 38W x 28.6D mm	50H x 50W x 25.6D mm	89H x 89W x 32D mm	89H x 89W x 32D mm	50H x 50W x 25.6D mm	89H x 89W x 32D mm
Weight <sup>d</sup>	200 g	200 g	200 g	680 g	620 g	200 g	620 g
<b>ORDERING INFORMATION<sup>d</sup></b>							
Standalone	UP10K-2S-H5-L-MT	UP12E-10S-H5-MT-B	UP19K-15S-H5-MT	UP25N-40S-H9-MT	UP55N-40S-H9-MT	UP19K-15S-W5-MT	UP50N-40S-W9-MT
Heatsink	---	---	UP19K-30H-H5-MT	UP25N-100H-H9-MT	UP55N-100H-H9-MT	UP19K-30H-W5-MT	UP50N-50H-W9-MT
Large Heatsink	---	---	UP19K-50L-H5-MT	---	---	UP19K-50L-W5-MT	---
Fan-Cooled	---	---	UP19K-110F-H9-MT	UP25N-250F-H12-MT	UP55N-300F-H12-MT	UP19K-50F-W5-MT	---
Water-Cooled	---	---	UP19K-150W-H5-MT	UP25M-350W-H12-MT	UP55M-500W-H12-MT	UP19K-50W-W5-MT	UP50M-50W-W9-MT
	---	---	UP19K-200W-H9-MT	---	UP55M-700W-HD-MT	---	---

\* Other Sizes Available Upon Request

Specifications are subject to change without notice

a. For model with the most efficient cooling module available.

b. 0.2 mW with anticipation.

c. At 1064 nm, 10 W, CW.

d. For convection-cooled models. Contact Gentec-EO for the weights and dimensions of the other cooling modules or see the specifications sheets of the corresponding UP Detectors.

# PRESENTATION

## OVERVIEW OF THE DIFFERENT PRODUCTS

Gentec Electro-Optics specializes in the measurement of laser radiation, in all its forms. This is why we have developed very specialized products over the years, that were first aimed at customized applications, but that became standard products as the demand grew stronger.



MACH 6



### ULTRAFAST JOULEMETER

- High Speed Digital Joulemeter: Measures EVERY PULSE up to 200 kHz
- Capture and Store up to 4 Million Pulses at the Maximum Repetition Rate
- Track Missing Pulses and Pulses below Threshold
- Wide Energy Range: Measure from pJ to mJ
- Spectral Range from 0.35 to 2.5  $\mu\text{m}$
- Sensors include Si, InGaAs and Pyroelectric
- Easy USB 2.0 Connection
- Includes Powerful LabView Software with Diagnostic Features

See page 142

THE FASTEST ENERGY METER ON THE MARKET:  
MEASURE EVERY PULSE UP TO 200 KHz

### DISCRETE PYROS

- TO5/TO8 Discrete or Hybrid Pyroelectric Detectors
- Available in 5 Sizes: 1, 2, 3, 5 and 9 mm  $\varnothing$  Apertures
- 5 Families of products to choose from
- Test Box Available for Hybrid Detectors

DISCRETE OR HYBRID PYROS  
SMALL TO5/TO8 PACKAGES

See page 148



QS SERIES

### POSITION SENSING DETECTORS

- Position Sensing QUADrant Pyroelectric Detectors
- Available for both Power (QUAD-P) and Energy (QUAD-E) Measurements
- Measure, Track and Align your Beam in Real Time
- For Wavelengths from UV to IR and even THz
- Large Apertures up to 20 x 20 mm



QUAD

POSITION SENSING QUADRANT DETECTORS

See page 156

# PRESENTATION

## CUSTOM PRODUCTS

After 40 years of experience in the Laser Beam Measurement business, we have developed many customized solutions, sometimes for very unusual applications! This section is only a small portion of the projects we have accomplished for our customers, so do not hesitate to contact us with any special need you may have. We are always striving to find the perfect solution for your application!

See page **160**



## CALORIMETERS

A Gentec-EO calorimeter is the only reliable solution available for the largest and highest energy laser beams. Through cooperation with several leading research facilities around the world, Gentec-EO has become the expert in manufacturing, calibrating and servicing calorimeters for use in high energy inertial confinement fusion calorimetric measurement.

■ EXTRA LARGE APERTURES UP TO 16 000 JOULES/PULSE

See page **164**



# MACH 6

200 kHz Energy Meter



200 kHz

Mach 6 Module

## KEY FEATURES

- UP TO 200 kHz PULSE-TO-PULSE**  
Measure EVERY pulse, with no sampling, at high rep rates, up to 200 kHz
- CAPTURE AND STORE UP TO 4 MILLION PULSES**  
Store 40 seconds of data at 100 kHz
- TRACK MISSING PULSES AND PULSES BELOW THRESHOLD**  
Know how many pulses were missed or that didn't make the energy threshold with this unique pulse feature
- SEVERAL HEADS TO CHOOSE FROM**  
Silicon, InGaAs and Pyroelectric heads for a broad wavelength and energy range
- ANALOG MODULE AVAILABLE**  
Use our fast M6 Detectors with the APM and an oscilloscope for fast analog energy measurements
- FULL-SPEED USB 2.0 CONNECTION**  
Ensures high data rate transfer and fast operation
- USER-FRIENDLY SOFTWARE WITH MANY DIAGNOSTIC FEATURES**
  - Live Mode, Strip Chart, Histogram and Statistics displays
  - FFT display of pulse energy data for temporal diagnostics
  - Life Test Mode to automate laser testing

## AVAILABLE MODELS

- M6-6-Si 6 mm Ø, Silicon Sensor (0.35-1.1  $\mu\text{m}$ )
- M6-6-Si-L 6 mm Ø, Silicon Sensor (0.35-1.1  $\mu\text{m}$ ), Low Noise Level
- M6-6-In 6 mm Ø, InGaAs Sensor (1.0-1.6  $\mu\text{m}$ )
- M6-6-In-L 6 mm Ø, InGaAs Sensor (1.0-1.6  $\mu\text{m}$ ), Low Noise Level
- M6-6-PY 6 mm Ø, Pyroelectric Sensor with Metallic Coating (0.35-2.5  $\mu\text{m}$ )
- M6-12.5-PY 12.5 mm Ø, Pyroelectric Sensor with Metallic Coating (0.35-2.5  $\mu\text{m}$ )

All M6 heads need to be used with the Mach 6 Energy Meter

## ACCESSORIES



Stand with Delrin Post  
(Model Number: 200428)



Additional 9V Power Supply  
(Model Number: 200960)



USB Cable  
(Model Number: 202373)



APM Analog Power Supply  
(Model Number: 201848)



M5-UC-QED  
Relative Measurements in UV



Pelican Carrying Case

## SEE ALSO

TECHNICAL DRAWINGS **168**

COMPATIBLE MODULES

MACH 6 

APM

LIST OF ALL ACCESSORIES **184**

APPLICATION NOTES:

PULSE-TO PULSE MEASUREMENTS AT 130 KHZ [201923](#)

MEASUREMENT LIMITS USING JOULEMETERS [201932](#)

Watch the demonstration video available on our website at [www.gentec-eo.com](http://www.gentec-eo.com)

## MACH 6



## SPECIFICATIONS

MACH 6	M6-6-Si	M6-6-Si-L	M6-6-In	M6-6-In-L	M6-6-PY	M6-12,5-PY
<b>MAX ENERGY</b>	200 µJ	2 µJ	200 µJ	2 µJ	20 mJ	200 mJ
<b>MAX AVERAGE POWER</b>	5 W	5 W	5 W	5 W	5 W	25 W
<b>MAX REP RATE</b>	200 000 Hz	200 000 Hz	200 000 Hz	200 000 Hz	200 000 Hz	200 000 Hz
<b>EFFECTIVE APERTURE</b>	6 mm Ø	6 mm Ø	6 mm Ø	6 mm Ø	6 mm Ø	12.5 mm Ø
<b>MEASUREMENT CAPABILITY</b>	With Mach 6	With Mach 6	With Mach 6	With Mach 6	With Mach 6	With Mach 6
Spectral Range	0.35 - 1.1 µm	0.35 - 1.1 µm	1.0 - 1.6 µm	1.0 - 1.6 µm	0.35 - 2.5 µm	0.35 - 2.5 µm
Max Measurable Energy <sup>a</sup>	200 µJ	2 µJ	200 µJ	2 µJ	20 mJ	200 mJ
Noise Equivalent Energy	2 nJ	20 pJ	2 nJ	20 pJ	0.2 µJ	2 µJ
Rise Time (0-100%)	150 ns	150 ns	150 ns	150 ns	150 ns	150 ns
Max Repetition Rate	200 000 Hz	200 000 Hz	200 000 Hz	200 000 Hz	200 000 Hz	200 000 Hz
Max Pulse Width	100 nsec	100 nsec	100 nsec	100 nsec	100 nsec	100 nsec
Calibration Uncertainty	± 4%	± 4%	± 4%	± 4%	± 4%	± 4%
Repeatability	± 1%	± 1%	± 1%	± 1%	± 1%	± 1%
<b>DAMAGE THRESHOLDS</b>						
Max Avg Power (60 seconds)	5 W	5 W	5 W	5 W	5 W	25 W
Max Probe Energy (@ 1064 nm)	200 µJ	2 µJ	200 µJ	2 µJ	20 mJ	200 mJ
<b>PHYSICAL CHARACTERISTICS</b>						
Effective Aperture	6 mm Ø	6 mm Ø	6 mm Ø	6 mm Ø	6 mm Ø	12.5 mm Ø
Sensor	Silicon	Silicon	InGaAs	InGaAs	Pyroelectric	Pyroelectric
Absorber	WA	WA	WA	WA	WA	WA
Dimensions	38.1 Ø x 58.4D mm	38.1 Ø x 58.4D mm	38.1 Ø x 58.4D mm	38.1 Ø x 58.4D mm	38.1 Ø x 58.4D mm	76H x 111W x 76D
Weight (Head only)	150 g	150 g	150 g	150 g	150 g	N/A
<b>ORDERING INFORMATION</b>						
Product Name	M6-6-Si	M6-6-Si-L	M6-6-In	M6-6-In-L	M6-6-PY	M6-12.5-PY
Product Number	202115	202116	202117	202118	202119	202120
Module	Mach 6: 202090					

Specifications are subject to change without notice

a. Maximum pulse energy reading will vary with wavelength and probe voltage responsivity (Rv). For more details, please read Application Note 121D-201932 and contact us at [info@gentec-eo.com](mailto:info@gentec-eo.com)

# MACH 6

MONITORS

ENERGY DETECTORS

POWER DETECTORS

HIGH POWER SOLUTIONS

PHOTO DETECTORS

THZ DETECTORS

OEM DETECTORS

SPECIAL PRODUCTS

BEAM DIAGNOSTICS



MACH 6  
(Front View)



MACH 6  
(Rear View)



## MACH 6 JOULEMETER

Measure every pulse at up to 200 kHz with MACH 6. Measure with 12-bit digital accuracy and capture up to 4 million pulses in real time. Our MACH 6 Joulemeter is the only instrument in the world that performs at this speed, and with this precision. It is designed to support our full complement of fast energy probes that include Silicon, InGaAs and Pyroelectric Detectors. Measure from pJ to mJ and from 0.35 to 2.5  $\mu\text{m}$ . Using the M6-Si detector and the M5-UC-QED accessory, you can make relative measurements at 266 nm.

## SPECIFICATIONS & FEATURES

MACH 6	
Compatible Detector Heads	M6
Maximum Repetition Rate	200 000 Hz
Analog Output	0-3 V
External Trigger (TTL)	Optically Coupled
Internal Trigger	2-20 %
Trigger Delay (User-Selectable)	38-3825 ns
Computer Input Connector	USB2.0
Product Number	202090

## INSTRUMENT CONTROL SCREEN

Our powerful LabView Application Software includes many unique control and diagnostic features. The Instrument Control Screen, shown on the left, is used to set up the operation of the MACH 6, including range, trigger, wavelength, and more. In addition, it is used to set a pulse batch size and to ARM the instrument, which starts the data collection. It also gives you access to features like "Autoset", "Call Live Mode", "Run Life Test", "Save Instrument Setup" and the like. These features can be accessed by clicking directly on the feature or pushing the associated function key.



## LIVE MODE DISPLAY

The Live mode can be accessed from the Instrument Control Screen, or by simply pressing the "F4" function key on your PC. This mode of operation is intended to act like your typical slower Digital Joulemeter, as it samples the laser pulses at a 10 Hz rate. It provides you with an energy strip chart, live energy reading, statistics and repetition rate. It is a very useful mode when setting up the Mach 6 with your laser. You can select "Auto Set", where the instrument runs through the ranges and trigger levels until it finds the correct range, or set them manually. When setup is complete, you will exit this screen and return to the "Control" screen where you will select a Batch Size, Arm the instrument and start taking pulse energy data.

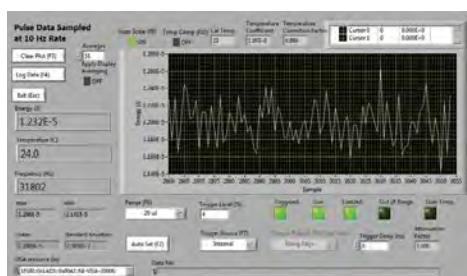

# MACH 6



## STRIP CHART

The Strip Chart Display provides a quick graphical look at the pulse data batch just collected. The data can be displayed in full scale or in auto scale mode. You can also zoom-in on a portion of the data, like shown in the screen on the left. An NDO.3 filter has been dropped through the beam and you can see the effects on the pulse data collected. You can fit trend and min/max lines to the data. Just below the chart, you will find a complete set of statistics for the batch. At the top of this screen you will see tabs that will take you to the Histogram, Statistics, and FFT (Fast Fourier Transform) displays.



## HISTOGRAM

Interested in viewing the statistical distribution of the pulse energy data set? The Histogram screen does this for you and fits a “best Gaussian curve” to the data. It displays complete statistical calculations along the bottom of the graph, along with pulse frequency. Just below the statistics, you will find instrument controls, like range and trigger. You are also given the ability to adjust trigger delay and hold off as needed.



## STATISTICS

The Statistics Display offers a very complete set of useful energy readings and calculated statistics. These include: minimum, maximum, average (mean), standard deviation, spread and variation. Some other very handy features include: windows displaying, Average Frequency, Pulse Jitter, Pulses Below Trigger and Pulses Below Threshold (a level set by you). In the screen on the left, you can see that there were 12 pulses below an energy threshold of 3 μW, and 147 missing pulses (or pulses below trigger).



## LIFE TEST MODE

Would you like to run a life test on your high repetition rate pulsed laser? How about a periodic test vs. an environmental change like temperature? We have included a great feature to accomplish this. In the Life Test screen, we give you the ability to select the statistics you want, a start time and date, a stop time and date, the number of pulses and a test interval. You simply identify a file, a place to put the data, and then click on start and walk away! When you come back, you have a data set that tracked the performance of your laser over time, temperature, shock, vibration or anything you chose.



MONITORS

ENERGY DETECTORS

POWER DETECTORS

HIGH POWER SOLUTIONS

PHOTO DETECTORS

THz DETECTORS

DEM DETECTORS

SPECIAL PRODUCTS

BEAM DIAGNOSTICS

# DISCRETE PYROS

MONITORS

ENERGY DETECTORS

POWER DETECTORS

HIGH POWER SOLUTIONS

PHOTO DETECTORS

THZ DETECTORS

OEM DETECTORS

SPECIAL PRODUCTS

BEAM DIAGNOSTICS



## KEY FEATURES

- BROAD SPECTRAL RESPONSE**  
From 0.1 to 1000  $\mu\text{m}$
- EASY TO INTEGRATE FORMAT**  
T05 and T08 packages make the QS detectors small and easy to integrate in an existing system
- LARGE AREA SENSORS**  
5 mm  $\varnothing$  and 9 mm  $\varnothing$  diameter pyroelectric sensors make optical alignment easier
- SEVERAL IR WINDOWS IN OPTION**
  - Quartz: 0.2 – 3.0  $\mu\text{m}$
  - Barium Fluoride: 0.2 – 17.5  $\mu\text{m}$
  - Sapphire: 0.1 – 7.0  $\mu\text{m}$
  - Silicon: 1.1 – 9.0  $\mu\text{m}$  and 50 – 1000  $\mu\text{m}$
  - AR Germanium: 8 – 14  $\mu\text{m}$

## AVAILABLE MODELS

5 families of products to choose from:

- QS-L Discrete Pyro Detectors, Low Noise Level
- QS-H Discrete Pyro Detectors, High Average Power
- QS-VL Hybrid Pyro Detectors, Voltage Mode, Low Noise Level
- QS-IF Hybrid Pyro Detectors, Current Mode, Fast Response
- QS-IL Hybrid Pyro Detectors, Current Mode, Low Noise Level

## ACCESSORIES



QS-I-TEST  
Evaluation Test Box (current)



QS-V-TEST  
Evaluation Test Box (voltage)



Permanent IR Windows  
(Various types available)



Pelican Carrying Case

## SEE ALSO

TECHNICAL DRAWINGS	<b>130</b>
ABSORPTION CURVES	<b>132</b>
LIST OF ALL ACCESSORIES	<b>184</b>
APPLICATION NOTES	
COMPENSATING CURRENT MODE AMPLIFICATION USING QS-I-TEST	<a href="#">201925</a>
HOW TO HANDLE SENSITIVE PYROELECTRIC DETECTORS	<a href="#">202181</a>
THERMAL SATURATION IN HYBRID PYROELECTRIC DETECTORS	<a href="#">201926</a>
HOW THEY WORK: QS-I-TEST & QS-V-TEST	<a href="#">201927</a>
HIGHEST PERFORMANCE WITH QS DETECTORS	<a href="#">201928</a>
QS DETECTORS PIN-OUTS & DESCRIPTIONS	<a href="#">201931</a>
QS-I-TEST SPECIFICATIONS	<a href="#">202187</a>

# QS-L

Discrete Pyro Detectors, Low Noise Level



Approved or in the process of being approved\*

## SPECIFICATIONS

	QS1-L	QS2-L	QS3-L	QS5-L	QS9-L
<b>CURRENT RESPONSIVITY</b>	1 $\mu\text{A/W}$	0.5 $\mu\text{A/W}$	0.5 $\mu\text{A/W}$	0.25 $\mu\text{A/W}$	0.25 $\mu\text{A/W}$
<b>EFFECTIVE APERTURE</b>	1 mm $\emptyset$	2 mm $\emptyset$	3 mm $\emptyset$	5 mm $\emptyset$	9 mm $\emptyset$
<b>PACKAGE</b>	T05	T05	T05	T05	T08
<b>MEASUREMENT CAPABILITY</b>					
Spectral Range	0.1 - 1000 $\mu\text{m}$	0.1 - 1000 $\mu\text{m}$	0.1 - 1000 $\mu\text{m}$	0.1 - 1000 $\mu\text{m}$	0.1 - 1000 $\mu\text{m}$
Max Average Power	50 mW	50 mW	50 mW	50 mW	50 mW
Capacitance (at 1000 Hz)	15 pF	22 pF	60 pF	90 pF	250 pF
Current Responsivity (at 630 nm)	1 $\mu\text{A/W}$	0.5 $\mu\text{A/W}$	0.5 $\mu\text{A/W}$	0.25 $\mu\text{A/W}$	0.25 $\mu\text{A/W}$
Thermal Frequency (3 dB)	3.5 Hz	1.6 Hz	0.8 Hz	0.5 Hz	0.25 Hz
Temperature Coefficient	0.2%/°C	0.2%/°C	0.2%/°C	0.2%/°C	0.2%/°C
<b>PHYSICAL CHARACTERISTICS</b>					
Effective Aperture	1 mm $\emptyset$	2 mm $\emptyset$	3 mm $\emptyset$	5 mm $\emptyset$	9 mm $\emptyset$
Package	T05	T05	T05	T05	T08
Sensor	Pyroelectric	Pyroelectric	Pyroelectric	Pyroelectric	Pyroelectric
Absorber	MT	MT	MT	MT	MT
Dimensions	8.3 $\emptyset$ x 6.4D mm	8.3 $\emptyset$ x 6.4D mm	8.3 $\emptyset$ x 6.4D mm	8.3 $\emptyset$ x 6.4D mm	13.6 $\emptyset$ x 6.4D mm
Weight	1.0 g	1.0 g	1.0 g	1.0 g	1.5 g
<b>ORDERING INFORMATION</b>					
Product Name	QS1-L	QS2-L	QS3-L	QS5-L	QS9-L
Product Number	201657	201659	201662	201664	201666

Specifications are subject to change without notice

# QS-H



Approved or in the process of being approved\*

Discrete Pyro Detectors, High Average Power

## SPECIFICATIONS

	QS1-H	QS2-H	QS3-H	QS5-H	QS9-H
<b>CURRENT RESPONSIVITY</b>	500 mW	500 mW	500 mW	500 mW	500 mW
<b>EFFECTIVE APERTURE</b>	1 mm Ø	2 mm Ø	3 mm Ø	5 mm Ø	9 mm Ø
<b>PACKAGE</b>	T05	T05	T05	T05	T08
<b>MEASUREMENT CAPABILITY</b>					
Spectral Range	0.1 - 1000 µm	0.1 - 1000 µm	0.1 - 1000 µm	0.1 - 1000 µm	0.1 - 1000 µm
Max Average Power	500 mW	500 mW	500 mW	500 mW	500 mW
Capacitance (at 1000 Hz)	3 pF	12 pF	30 pF	90 pF	250 pF
Current Responsivity (at 630 nm)	0.25 µA/W	0.25 µA/W	0.25 µA/W	0.25 µA/W	0.25 µA/W
Thermal Frequency (3 dB)	5 Hz	5 Hz	5 Hz	5 Hz	5 Hz
Temperature Coefficient	0.2%/°C	0.2%/°C	0.2%/°C	0.2%/°C	0.2%/°C
<b>PHYSICAL CHARACTERISTICS</b>					
Effective Aperture	1 mm Ø	2 mm Ø	3 mm Ø	5 mm Ø	9 mm Ø
Package	T05	T05	T05	T05	T08
Sensor	Pyroelectric	Pyroelectric	Pyroelectric	Pyroelectric	Pyroelectric
Absorber	MT	MT	MT	MT	MT
Dimensions	8.3Ø x 6.4D mm	8.3Ø x 6.4D mm	8.3Ø x 6.4D mm	8.3Ø x 6.4D mm	13.6Ø x 6.4D mm
Weight	1.0 g	1.0 g	1.0 g	1.0 g	1.5 g
<b>ORDERING INFORMATION</b>					
Product Name	QS1-H	QS2-H	QS3-H	QS5-H	QS9-H
Product Number	201658	201661	201663	201665	201667

Specifications are subject to change without notice

# QS-VL

Hybrid Pyro Detectors, Voltage Mode, Low Noise Level



Approved or in the process of being approved\*

## SPECIFICATIONS

	QS1-VL	QS2-VL	QS3-VL	QS5-VL	QS9-VL
<b>VOLTAGE RESPONSIVITY</b>	900 V/W	200 V/W	90 V/W	25 V/W	15 V/W
<b>CURRENT RESPONSIVITY</b>	1 $\mu$ A/W	0.5 $\mu$ A/W	0.5 $\mu$ A/W	0.25 $\mu$ A/W	0.25 $\mu$ A/W
<b>EFFECTIVE APERTURE</b>	1 mm $\emptyset$	2 mm $\emptyset$	3 mm $\emptyset$	5 mm $\emptyset$	9 mm $\emptyset$
<b>PACKAGE</b>	T05	T05	T05	T05	T08

### MEASUREMENT CAPABILITY

Spectral Range	0.1 - 1000 $\mu$ m	0.1 - 1000 $\mu$ m	0.1 - 1000 $\mu$ m	0.1 - 1000 $\mu$ m	0.1 - 1000 $\mu$ m
Max Average Power	50 mW	50 mW	50 mW	50 mW	50 mW
Noise Equivalent Power <sup>a</sup>	$3 \times 10^{-10}$ W/(Hz) <sup>1/2</sup>	$6 \times 10^{-10}$ W/(Hz) <sup>1/2</sup>	$1 \times 10^{-9}$ W/(Hz) <sup>1/2</sup>	$2 \times 10^{-9}$ W/(Hz) <sup>1/2</sup>	$5 \times 10^{-9}$ W/(Hz) <sup>1/2</sup>
Detectivity <sup>a</sup>	$2.9 \times 10^8$ cm(Hz) <sup>1/2</sup> /W	$3.0 \times 10^8$ cm(Hz) <sup>1/2</sup> /W	$2.7 \times 10^8$ cm(Hz) <sup>1/2</sup> /W	$2.2 \times 10^8$ cm(Hz) <sup>1/2</sup> /W	$1.6 \times 10^8$ cm(Hz) <sup>1/2</sup> /W
Capacitance (at 1000 Hz)	15 pF	22 pF	60 pF	90 pF	250 pF
Current Responsivity (at 630 nm)	1 $\mu$ A/W	0.5 $\mu$ A/W	0.5 $\mu$ A/W	0.25 $\mu$ A/W	0.25 $\mu$ A/W
Voltage Responsivity <sup>b</sup>	900 V/W	200 V/W	90 V/W	25 V/W	15 V/W
Thermal Frequency (3 dB)	3.5 Hz	1.6 Hz	0.8 Hz	0.5 Hz	2.5 Hz
Load Resistor	300 G $\Omega$	300 G $\Omega$	100 G $\Omega$	100 G $\Omega$	100 G $\Omega$
Supply Voltage	+9 to +15 V	+9 to +15 V	+9 to +15 V	+9 to +15 V	+9 to +15 V

### PHYSICAL CHARACTERISTICS

Effective Aperture	1 mm $\emptyset$	2 mm $\emptyset$	3 mm $\emptyset$	5 mm $\emptyset$	9 mm $\emptyset$
Package	T05	T05	T05	T05	T08
Sensor	Pyroelectric	Pyroelectric	Pyroelectric	Pyroelectric	Pyroelectric
Absorber	MT	MT	MT	MT	MT
Dimensions	8.3 $\emptyset$ x 6.4D mm	8.3 $\emptyset$ x 6.4D mm	8.3 $\emptyset$ x 6.4D mm	8.3 $\emptyset$ x 6.4D mm	13.6 $\emptyset$ x 6.4D mm
Weight	1.0 g	1.0 g	1.0 g	1.0 g	1.5 g

### ORDERING INFORMATION

Product Name	QS1-VL	QS2-VL	QS3-VL	QS5-VL	QS9-VL
Product Number	201673	201674	201676	201677	201678

Specifications are subject to change without notice

a. 630 nm, 15 Hz, 1 Hz Bandwidth

b. 630 nm, 15 Hz



## QS-V-TEST EVALUATION TEST BOX

QS-V-TEST	
Batteries	+9V
R <sub>i</sub> Resistors	$10^5 - 10^{10} \Omega$
C <sub>i</sub> Compensating	NO
Package	101.6H x 127W x 58.4D
Optical Mount	1/4-20 Threaded
Front Bezel	SM1 (1.035-40)
Product Number	201694

\* For details, contact your Gentec-EO representative

# QS-IF



Approved or in the process of being approved\*

Hybrid Pyro Detectors, Current Mode, Fast Response

## SPECIFICATIONS

	QS1-IF	QS2-IF	QS3-IF	QS5-IF	QS9-IF
<b>VOLTAGE RESPONSIVITY</b>	100 V/W	50 V/W	50 V/W	25 V/W	25 V/W
<b>CURRENT RESPONSIVITY</b>	1 $\mu$ A/W	0.5 $\mu$ A/W	0.5 $\mu$ A/W	0.25 $\mu$ A/W	0.25 $\mu$ A/W
<b>EFFECTIVE APERTURE</b>	1 mm $\emptyset$	2 mm $\emptyset$	3 mm $\emptyset$	5 mm $\emptyset$	9 mm $\emptyset$
<b>PACKAGE</b>	T05	T05	T05	T05	T08

### MEASUREMENT CAPABILITY

Spectral Range	0.1 - 1000 $\mu$ m	0.1 - 1000 $\mu$ m	0.1 - 1000 $\mu$ m	0.1 - 1000 $\mu$ m	0.1 - 1000 $\mu$ m
Max Average Power	50 mW	50 mW	50 mW	50 mW	50 mW
Noise Equivalent Power <sup>a</sup>	$5 \times 10^{-8}$ W/(Hz) <sup>1/2</sup>	$8 \times 10^{-8}$ W/(Hz) <sup>1/2</sup>	$8 \times 10^{-8}$ W/(Hz) <sup>1/2</sup>	$1.6 \times 10^{-7}$ W/(Hz) <sup>1/2</sup>	$1.6 \times 10^{-7}$ W/(Hz) <sup>1/2</sup>
Detectivity <sup>a</sup>	$1.8 \times 10^6$ cm(Hz) <sup>1/2</sup> /W	$2.2 \times 10^6$ cm(Hz) <sup>1/2</sup> /W	$3.3 \times 10^6$ cm(Hz) <sup>1/2</sup> /W	$2.8 \times 10^6$ cm(Hz) <sup>1/2</sup> /W	$5.0 \times 10^6$ cm(Hz) <sup>1/2</sup> /W
Capacitance (at 1000 Hz)	15 pF	22 pF	60 pF	90 pF	250 pF
Current Responsivity (at 630 nm)	1 $\mu$ A/W	0.5 $\mu$ A/W	0.5 $\mu$ A/W	0.25 $\mu$ A/W	0.25 $\mu$ A/W
Voltage Responsivity <sup>b</sup>	100 V/W	50 V/W	50 V/W	25 V/W	25 V/W
Thermal Frequency (3 dB)	3.5 Hz	1.6 Hz	0.8 Hz	0.5 Hz	0.25 Hz
Feedback Resistor	100 M $\Omega$	100 M $\Omega$	100 M $\Omega$	100 M $\Omega$	100 M $\Omega$
Supply Voltage	$\pm 12$ V	$\pm 12$ V	$\pm 12$ V	$\pm 12$ V	$\pm 12$ V

### PHYSICAL CHARACTERISTICS

Effective Aperture	1 mm $\emptyset$	2 mm $\emptyset$	3 mm $\emptyset$	5 mm $\emptyset$	9 mm $\emptyset$
Package	T05	T05	T05	T05	T08
Sensor	Pyroelectric	Pyroelectric	Pyroelectric	Pyroelectric	Pyroelectric
Absorber	MT	MT	MT	MT	MT
Dimensions	8.3 $\emptyset$ x 6.4D mm	8.3 $\emptyset$ x 6.4D mm	8.3 $\emptyset$ x 6.4D mm	8.3 $\emptyset$ x 6.4D mm	13.6 $\emptyset$ x 6.4D mm
Weight	1.0 g	1.0 g	1.0 g	1.0 g	1.5 g

### ORDERING INFORMATION

Product Name	QS1-IF	QS2-IF	QS3-IF	QS5-IF	QS9-IF
Product Number	201679	201680	201681	201682	201683

Specifications are subject to change without notice

a. 630 nm, 15 Hz, largeur de bande de 1 Hz

b. 630 nm, 15 Hz



## QS-I-TEST EVALUATION TEST BOX

QS-I-TEST	
Batteries	+9V/-9V
R <sub>i</sub> Resistors	10 <sup>5</sup> - 10 <sup>10</sup> $\Omega$
C <sub>i</sub> Compensating	OUI
Package	101,6H x 127L x 58,4P
Optical Mount	Filetage 1/4-20
Front Bezel	SM1 (1,035-40)
Product Number	201693

\* For details, contact your Gentec-EO representative

# QS-IL



Approved or in the process of being approved\*

Hybrid Pyro Detectors, Current Mode, Low Noise Level

## SPECIFICATIONS

	QS1-IL	QS2-IL	QS3-IL	QS5-IL	QS9-IL
<b>VOLTAGE RESPONSIVITY</b>	50 kV/W	25 kV/W	25 kV/W	13 kV/W	13 kV/W
<b>CURRENT RESPONSIVITY</b>	1 $\mu$ A/W	0.5 $\mu$ A/W	0.5 $\mu$ A/W	0.25 $\mu$ A/W	0.25 $\mu$ A/W
<b>EFFECTIVE APERTURE</b>	1 mm $\emptyset$	2 mm $\emptyset$	3 mm $\emptyset$	5 mm $\emptyset$	9 mm $\emptyset$
<b>PACKAGE</b>	T05	T05	T05	T05	T08

### MEASUREMENT CAPABILITY

Spectral Range	0.1 - 1000 $\mu$ m	0.1 - 1000 $\mu$ m	0.1 - 1000 $\mu$ m	0.1 - 1000 $\mu$ m	0.1 - 1000 $\mu$ m
Max Average Power	50 mW	50 mW	50 mW	50 mW	50 mW
Noise Equivalent Power <sup>a</sup>	$8 \times 10^{-10}$ W/(Hz) <sup>1/2</sup>	$2 \times 10^{-9}$ W/(Hz) <sup>1/2</sup>	$2 \times 10^{-9}$ W/(Hz) <sup>1/2</sup>	$6 \times 10^{-9}$ W/(Hz) <sup>1/2</sup>	$6 \times 10^{-9}$ W/(Hz) <sup>1/2</sup>
Detectivity <sup>a</sup>	$1.1 \times 10^8$ cm(Hz) <sup>1/2</sup> /W	$9.0 \times 10^7$ cm(Hz) <sup>1/2</sup> /W	$1.3 \times 10^8$ cm(Hz) <sup>1/2</sup> /W	$7.0 \times 10^7$ cm(Hz) <sup>1/2</sup> /W	$1.3 \times 10^8$ cm(Hz) <sup>1/2</sup> /W
Capacitance (at 1000 Hz)	15 pF	22 pF	60 pF	90 pF	250 pF
Current Responsivity (at 630 nm)	1 $\mu$ A/W	0.5 $\mu$ A/W	0.5 $\mu$ A/W	0.25 $\mu$ A/W	0.25 $\mu$ A/W
Voltage Responsivity <sup>b</sup>	50 kV/W	25 kV/W	25 kV/W	13 kV/W	13 kV/W
Thermal Frequency (3 dB)	3.5 Hz	1.6 Hz	0.8 Hz	0.5 Hz	0.25 Hz
Feedback Resistor	100 G $\Omega$	100 G $\Omega$	100 G $\Omega$	100 G $\Omega$	100 G $\Omega$
Supply Voltage	$\pm 5$ to $\pm 12$ V	$\pm 5$ to $\pm 12$ V	$\pm 5$ to $\pm 12$ V	$\pm 5$ to $\pm 12$ V	$\pm 5$ to $\pm 12$ V

### PHYSICAL CHARACTERISTICS

Effective Aperture	1 mm $\emptyset$	2 mm $\emptyset$	3 mm $\emptyset$	5 mm $\emptyset$	9 mm $\emptyset$
Package	T05	T05	T05	T05	T08
Sensor	Pyroelectric	Pyroelectric	Pyroelectric	Pyroelectric	Pyroelectric
Absorber	MT	MT	MT	MT	MT
Dimensions	8.3 $\emptyset$ x 6.4D mm	8.3 $\emptyset$ x 6.4D mm	8.3 $\emptyset$ x 6.4D mm	8.3 $\emptyset$ x 6.4D mm	13.6 $\emptyset$ x 6.4D mm
Weight	1.0 g	1.0 g	1.0 g	1.0 g	1.5 g

### ORDERING INFORMATION

Product Name	QS1-IL	QS2-IL	QS3-IL	QS5-IL	QS9-IL
Product Number	201684	201685	201686	201687	201688

Specifications are subject to change without notice

a. 630 nm, 15 Hz, 1 Hz Bandwidth

b. 630 nm, 15 Hz



## QS-I-TEST EVALUATION TEST BOX

QS-I-TEST	
Batteries	+9V/-9V
R, Resistors	$10^5$ - $10^{10}$ $\Omega$
C, Compensating	OUI
Package	101,6H x 127L x 58,4P
Optical Mount	Filetage 1/4-20
Front Bezel	SM1 (1,035-40)
Product Number	201693

\* For details, contact your Gentec-EO representative

# DISCRETE PYROS



## PYROELECTRIC THERMAL DETECTORS

Our pyroelectric detectors are a class of room temperature thermal detectors that produce a current output that is directly proportional to the rate of change of temperature when exposed to a source of radiation. They are best described by an AC current source, capacitor and resistor. Their current output is governed by the equation  $I = p(T) \cdot A \cdot dT/dt$ , where  $I$  is current,  $p(T)$  is the Pyro Coefficient,  $A$  is the area as defined by the front electrode, and  $dT/dt$  is the rate of temperature change of the pyro crystal. The advantages of a pyroelectric detector over other IR detectors are: room temperature operation, broad spectral response, high sensitivity ( $D^*$ ) and fast response (sub-nsec into  $50 \Omega$ ).

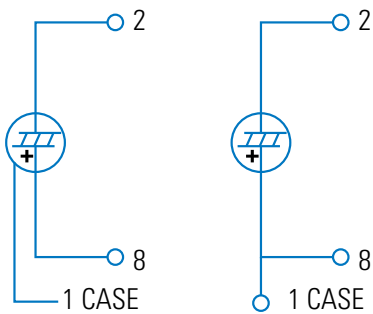

QS-L (left) and QS-H (right) Pin-Outs

## QS-L AND QS-H DISCRETE PYROS

Our passive Discrete Pyroelectric Detectors range from 1 to 9 mm in diameter and are provided in two configurations: high sensitivity or high average power. They present a pyroelectric detector element covered with our metallic coating (MT) and are packaged in a miniature TO-5 or TO-8 can. The diagram shown left identifies the Pin-out for both types of detectors. Our organic black coating (BL), increases the optical absorption and helps flatten the spectral response. We also offer a number of permanent IR Windows that can be added to the TO can. These discrete pyro detectors are ideal for pulsed laser applications.

## QS-VL VOLTAGE MODE HYBRID PYROS

Pyroelectric Detectors are high impedance ( $>10^{13} \Omega$ ) devices that require use in an impedance converting circuit when trying to achieve the highest sensitivity (high  $D^*$ ). Our QS-VL Series detectors include our pyroelectric element mated to an ultra-low noise FET in a source follower circuit. These are in turn packaged in a miniature TO-5 or TO-8 can. The equivalent circuit and Pin-out for this series are shown at the left. They are also available in sizes ranging from 1 to 9 mm diameter. These models are ideal for analytical instrumentation applications like Broadband IR Radiometers, Optical Pyrometer, and/or FTIR Spectrometers.

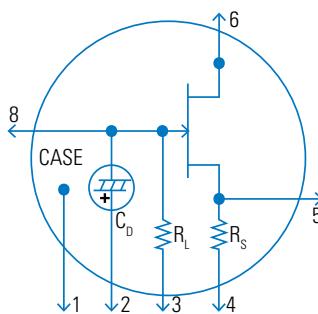

QS-VL Pin-Out

## QS-IF AND QS-IL CURRENT MODE HYBRID PYROS

These detectors offer high gain ( $>10^5$  V/W) and/or high bandwidth ( $>10$  MHz). In this configuration, the pyroelectric detector element is combined to a low noise operational amplifier. The QS-IL models are designed for high performance at low to medium frequencies, while the QS-IF models offer good performance at medium to high frequencies. These detectors are very easy to use. Simply supply the +/- 10 to 15 V to power the operational amplifier and add an external resistor, if required, to adjust the bandwidth and you are ready to measure pulsed, modulated or chopped sources, from nJ to mJ and nW to W. These detectors also make great candidates for any variety of broadband analytical instruments or laser measurement products.

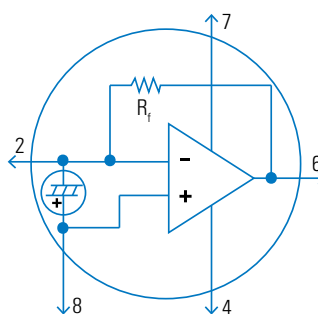

QS-IF and QS-IL Pin-Out

# DISCRETE PYROS

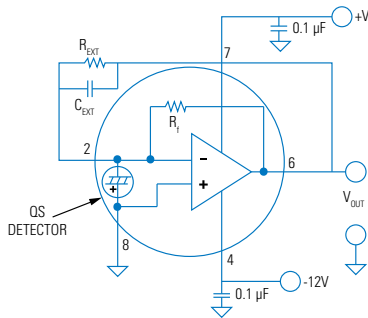

QS-VL and QS-IL Circuitry

## VOLTAGE OUTPUT VS. FREQUENCY

Our QS-VL and QS-IL Hybrid Detectors are designed to maximize voltage output at low frequencies and therefore include load and feedback resistors in the 100 GΩ to 300 GΩ range. They are also designed into 8-pin TO packages that allow the addition of an “external resistor” to lower the output and increase the bandwidth. The circuit diagram at the left shows a typical hook up for our QS5-IL detector (with our MT coating), using external resistors and capacitors. Our QS-IF series, on the other hand, are designed for high bandwidth applications and therefore include a smaller feedback resistor of 100 MΩ. For expert help on designing a detector circuit please contact us [info@gentec-eo.com](mailto:info@gentec-eo.com).

## OPERATION IN POWER MEASUREMENT MODE

When using our QS-IL Hybrid Detector to measure the Power (in Watts) of your CW or High Rep Rate source (Quasi-CW), you will need to employ an optical chopper. The diagram at the left shows the typical voltage output of a QS5-IL when used with our QS-I-TEST evaluation test box. Note that the voltage output is an approximate “square wave” whose rise and fall times are governed by the RC time constant of the circuit. The optical power is directly proportional to the peak voltage minus the baseline voltage. We calibrate these devices when operating in this mode.

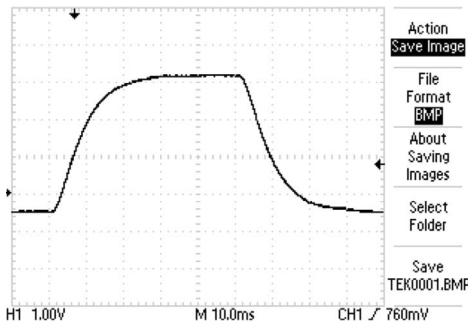

Typical QS-IL Voltage Output in Power Measurement Mode

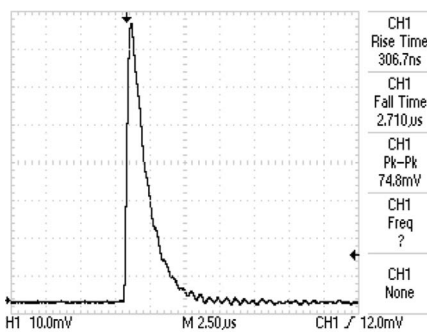

Typical QS-IL Voltage Output in Energy Measurement Mode

## OPERATION IN ENERGY MEASUREMENT MODE

Our Pyroelectric Detectors are an ideal choice when measuring the performance of your pulsed laser in the range of nJ to mJ, across the full spectrum! The scope trace at the left represents the typical output from a QS9-IL, when used with our QS-I-TEST set up as an integrating Joulemeter. Note the fast rise to a peak and then slower decay governed by the RC time constant selected for the integrating circuit. In this configuration you can measure absolute pulse energy, rep rate, and pulse-to-pulse stability. The maximum pulse width of your source is determined by the RC time constant you select and there is no limit as to how short the pulse can be!

## BROAD SPECTRAL RESPONSE

Unlike photoconductive and photovoltaic detectors, our Pyroelectric Thermal Detectors are not limited to a small part of the electromagnetic spectrum. They are truly broad spectrum detectors, sensitive from 0.1 μm to 3000 μm (EUV, FAR IR, and THz). Any and all radiation absorbed by our coatings or pyro crystal will result in a measurable signal. The two plots at the left show the relative spectral response of detectors with MT and BL coatings. Note that the well documented, NIST traceable calibrated portion of these curves runs from 0.25 μm to 15 μm. There are currently no traceable optical standards for measurements > 15 μm.

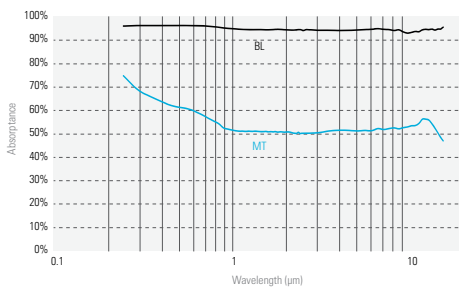

Absorption Curves of QS Pyroelectric Detectors

# QUAD

Position Sensing Power & Energy Detectors



QUAD-4Track Module

## FEATURES

- 1. MEASURE, TRACK AND ALIGN**  
With  $\mu\text{m}$  resolution in real time!
- 2. 4-CHANNEL DETECTORS**  
Unique pyroelectric QUADrant detector technology handles high peak power without saturation
- 3. FOR CW, PULSED AND HIGH REP RATE LASERS**
  - QUAD-E: Energy per pulse from  $\mu\text{J}$  to  $\text{mJ}$
  - QUAD-P: Powers from  $\mu\text{W}$  to  $\text{mW}$
- 4. FROM UV TO FIR AND THz**  
Broadband detectors cover the full spectrum, from UV to Sub-Millimeter wavelengths
- 5. LARGE AREA SENSORS**  
9 mm and 20 mm square detectors
- 6. FAST USB 2.0 CONNECTION**  
Ensures full speed tracking
- 7. INCLUDES APPLICATION SOFTWARE**  
Complete LabView Application Software included, with many features

## CONNECTIVITY



QUAD-9-MT-E  
(9 x 9 mm-For Energy)



QUAD-20-MT-E  
(20 x 20 mm-For Energy)



QUAD-9-MT-P  
(9 x 9 mm-For Power)



QUAD-20-MT-P  
(20 x 20 mm-For Power)

## ACCESSORIES



Stand with Delrin Post  
(Model Number: 200428)



Additional 9V Power Supply  
(Model Number: 200960)



USB Cable  
(Model Number: 202373)



SDC-500 Digital  
Optical Chopper (for -P)



Pelican Carrying Case

## SEE ALSO

TECHNICAL DRAWINGS	<b>130</b>
LIST OF ALL ACCESSORIES	<b>184</b>

### APPLICATION NOTES

LASER POSITION SENSING DETECTORS  
AND MONITOR [201930](#)

SDC-500 DIGITAL OPTICAL CHOPPER [202154](#)

Watch the demonstration video available on our website at [www.gentec-eo.com](http://www.gentec-eo.com)

# QUAD



## SPECIFICATIONS

	QUAD-9-MT-E / QUAD-9-MT-P	QUAD-20-MT-E / QUAD-20-MT-P		
<b>MAX ENERGY / AVG POWER</b>	20 mJ / 200 mW	20 mJ / 200 mW		
<b>MAX POSITION RESOLUTION</b>	1 $\mu\text{m}$ / 10 $\mu\text{m}$	1 $\mu\text{m}$ / 10 $\mu\text{m}$		
<b>EFFECTIVE APERTURE</b>	9 x 9 mm	20 x 20 mm		
<b>MEASUREMENT CAPABILITY</b>				
Spectral Range	0.1 - 3000 $\mu\text{m}$	0.1 - 3000 $\mu\text{m}$		
Min Beam Size <sup>a</sup>	$\geq 4.5$ mm $\emptyset$	$\geq 10$ mm $\emptyset$		
For -E (Energy sensors)				
Max Measurable Energy	20 mJ/Channel	20 mJ/Channel		
Noise Equivalent Energy	0.5 $\mu\text{J}$	1.0 $\mu\text{J}$		
Rise Time (0-100%)	150 $\mu\text{s}$	150 $\mu\text{s}$		
Max Repetition Rate	1000 Hz	1000 Hz		
Max Pulse Width	2.5 $\mu\text{sec}$	2.5 $\mu\text{sec}$		
Sensitivity	1000 V/J	1000 V/J		
For -P (Power sensors)				
Max Measurable Power	200 mW	200 mW		
Noise Equivalent Power	1 $\mu\text{W}$	2 $\mu\text{W}$		
Rise Time (0-100%)	< 0.02 s	< 0.02 s		
Max Chopping Frequency	50 Hz	50 Hz		
Sensitivity	2000 V/W	2000 V/W		
Calibration Uncertainty	$\pm 4\%$	$\pm 4\%$		
Minimum Position Resolution	-E: 1 $\mu\text{m}$	-E: 1 $\mu\text{m}$		
With QUAD-4Track Monitor	-P: 10 $\mu\text{m}$	-P: 10 $\mu\text{m}$		
<b>DAMAGE THRESHOLDS</b>				
Max Average Power Density (@ 1.064 $\mu\text{m}$ )	100 mW/cm <sup>2</sup>	100 mW/cm <sup>2</sup>		
Max Energy Density (@ 1.064 $\mu\text{m}$ 10 ns)	50 mJ/cm <sup>2</sup>	50 mJ/cm <sup>2</sup>		
<b>PHYSICAL CHARACTERISTICS</b>				
Effective Aperture	9 x 9 mm	20 x 20 mm		
Sensor	Pyroelectric	Pyroelectric		
Absorber	MT	MT		
Dimensions	63.5 $\emptyset$ X 40.6D mm	63.5 $\emptyset$ X 40.6D mm		
Weight	181 g	181 g		
<b>ORDERING INFORMATION</b>				
Product Name (Detectors)	QUAD-9-MT-E	QUAD-9-MT-P	QUAD-20-MT-E	QUAD-20-MT-P
Product Number	201774	201776	201775	201777
Product Name (Module)	QUAD-4Track			
Product Number	201517			

Specifications are subject to change without notice

a. For optimal performance.

\* For details, contact your Gentec-EO representative

# QUAD



QUAD-4Track  
(Front View)



QUAD-4Track  
(Rear View)



## QUAD-4TRACK

The QUAD-4Track is a Laser Position Sensing system designed to support our unique Pyroelectric Quadrant Detectors, QUAD-P and QUAD-E. It is a 4-channel microprocessor-based system that measures the voltage output of each QUAD element and does the math necessary to provide a measurement of the X and Y displacement of a laser beam or image. It is fast and can be used to track, align and/or measure movement in real time, with a resolution of just a few microns!

## SPECIFICATIONS & FEATURES

### QUAD-4TRACK

Number of Channels	4
Full Scale Ranges (4 Decades) (E / P)	
Joulemeter Mode (with QUAD-E)	20 $\mu$ J to 20 mJ
Radiometer Mode (with QUAD-P)	200 $\mu$ W to 200 mW
USB Connection to Computer	YES (USB 2.0 Full Speed)
Power Supply	9VDC
Power On Light	YES
Detector Input	DB-25 Connector
Detector Analog Output	BNC Connector (0-2 V)
Trigger Input (TTL)	BNC Connector with LED Indicator
Product Number	201517

## QUAD DETECTORS

Our large area Pyroelectric Quadrant Detectors provide unique advantages over other position sensing detectors like Silicon quads or lateral effect photodiodes. They are fast, handle high peak power of pulsed lasers without saturation and respond to lasers across the spectrum, from UV to Far IR and even THz. The QUAD-E is intended for use with pulsed sources at up to 1000 Hz, while the QUAD-P is designed for CW and High Repetition Rate (Quasi CW) sources. Both types of detectors can also be used as standalone units, in an analog mode, for incorporation into your own system application. We can provide a Lemo pigtail cable for this purpose.

## ANALOG OUTPUT

The analog output of the QUAD-4Track provides voltage that is directly proportional to the pulse energy or laser power irradiating each QUAD element. When the four voltage outputs are equal, the beam is centered on the QUAD detector. This provides a very useful tool when setting up our QUAD probes with your source for optical alignment.

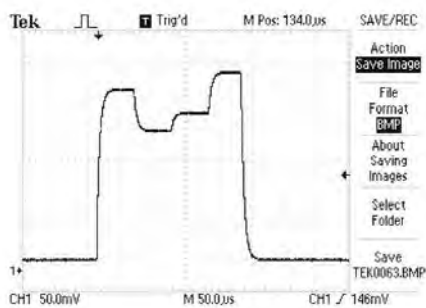

# QUAD



## MEASUREMENT SCREEN

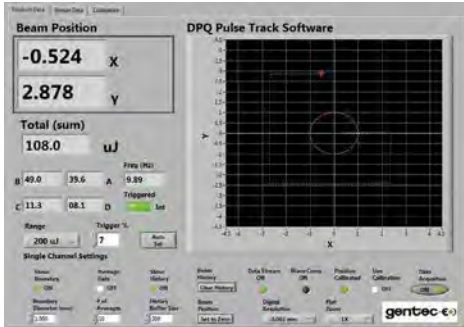

QUAD-4Track includes powerful, stand alone, LabView Software which is used to control the instrument, process the data, and display X and Y position. It also displays the energy or power of your source and repetition rate. The large graphic in this screen shows the position of the centroid of the beam and tracks its movement in real time. The software includes many handy features like: set boundary, zoom (2X to 128X), set resolution, data logging, and many more. The green line represents the tracking history.

## TRACKING THE BEAM OVER TIME

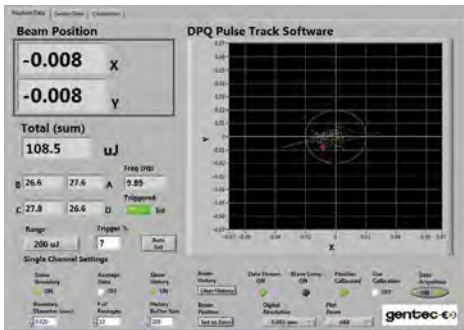

In the measurement screen shown on the left, we are tracking the beam stability of a pulsed Nd:YLF laser at 10 Hz. The resolution was set at 0.001 nm, the boundary is at 20 μm (red circle), and the zoom feature is at 64X. The total energy is 108.5 μJ, the final position of the laser is at -8 μm in X and -8 μm in Y. The green tracking line shows the movement of the laser about the zero position over a few hundred pulses.

## POSITION CALIBRATION SCREEN

Set Positions	Measured Positions	Corrected Positions	Coefficients
-2.00E+0	-4.14E+0	-2.00E+0	7.32E-3
-1.50E+0	-3.66E+0	-1.50E+0	3.14E-1
-1.00E+0	-2.77E+0	-9.99E-1	-4.03E-3
-5.00E-1	-1.51E+0	-5.01E-1	9.94E-3
0.00E+0	-1.86E-2	1.46E-3	6.40E-4
5.00E-1	1.50E+0	4.99E-1	-8.66E-4
1.00E+0	2.76E+0	1.00E+0	-2.17E-5
1.50E+0	3.62E+0	1.50E+0	5.12E-5
2.00E+0	4.11E+0	2.00E+0	

We've developed a unique position calibration routine which allows you to calibrate our QUAD-4Track system when working with a uniformly round laser beam. It requires the use of a micrometer-driven linear stage (1-axis only). As you can see from the calibration screen on the left, the procedure involves zeroing the instrument, moving the QUAD probe to nine discrete positions (+2.000 to -2.000 mm) and then capturing the QUAD readings. It then determines correction coefficients (last column) and applies them to the raw data to arrive at "corrected positions". The QUAD probe is now calibrated!

## DATA LOGGING

Time	Energy (uJ)	X	Y
54:01.9	100.3	-0.008	-0.023
54:05.9	100.3	-0.013	-0.024
54:09.9	100.4	-0.015	-0.02
54:13.9	100.4	0.04	0.025
54:17.9	100.4	0.029	-0.069
54:22.0	100.4	-0.376	-0.08
54:26.0	100.3	-0.041	-0.069
54:30.0	100.4	-0.036	-0.073

Another very handy feature is "data logging". This allows you to set up the QUAD-4Track to follow the displacement, energy and/or power of your laser over several minutes, hours or even days. Need to measure the "beam steering" of your laser as it warms up? This is how you do it! Need to measure the beam displacement vs laser repetition rate or energy level? Data logging will help you measure it!

MONITORS

ENERGY DETECTORS

POWER DETECTORS

HIGH POWER SOLUTIONS

PHOTO DETECTORS

THZ DETECTORS

OEM DETECTORS

SPECIAL PRODUCTS

BEAM DIAGNOSTICS

# CUSTOM PRODUCTS



After 40 years of experience in the Laser Beam Measurement business, we have developed many customized solutions, sometimes for very unusual applications! This section is only a small portion of the projects we have accomplished for our customers, so do not hesitate to contact us with any special need you may have. We are always striving to find the perfect solution for your application!

# CUSTOM PRODUCTS

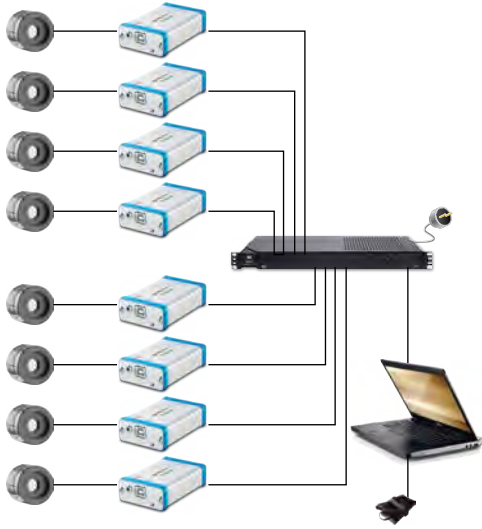

## OCTOLINK

OCTOLINK is our multichannel software that was specifically designed for the simultaneous measurement of a large set of power detectors. As its name indicates, OCTOLINK allows the measurement of up to 8 devices simultaneously, all on a combined control screen. Furthermore, this tool offers full flexibility on the functionalities, allowing to control, compare and collect data of multiple detectors in a simple but effective manner. The channels can be user-set, allowing a transparent integration in the existing systems. Pass-fail feature and complete data logging make OCTOLINK an ideal and inexpensive solution for long term power monitoring.

- MEASURE 8 DETECTORS SIMULTANEOUSLY
- USER-SETTABLE INTERFACE

## 6-ELEMENT DETECTOR BAR

Custom detector integration that monitors multiple lasers in a system. This detector bar included six independent power sensors, covered by protection windows with anti-reflective coating, presence sensors, on-board signal conditioning and acquisition to instantly measure power and communicate with the system through industrial serial protocol.

- 6 ELEMENTS ON ONE BOARD
- INSTANTANEOUS POWER MEASUREMENT OF ALL 6 ELEMENTS
- DETECTOR ELEMENTS PROTECTED BY WINDOWS WITH AR COATING

## 8-CHANNEL ARRAY FOR THZ TOMOGRAPHY

The 8 element Pyroelectric Array and electronics were designed for a Fiber Laser-based, multi-beam, THz Tomography project which was a joint venture between the Universities of Manchester, Southampton and Leeds in the UK.

The goal was to produce a high performance, low noise level, discrete array, capable of measuring 10 nW per channel in the 0.5 to 2 THz range.

- 8-CHANNEL PYROELECTRIC ARRAY
- 0.5 TO 2 THZ RANGE
- 10 nW PER CHANNEL

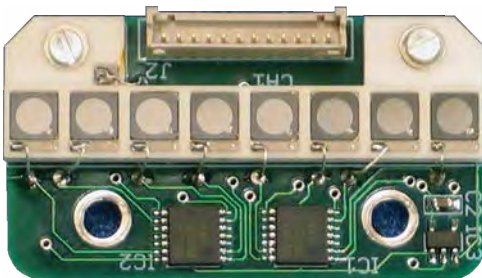

# CUSTOM PRODUCTS

MONITORS

ENERGY DETECTORS

POWER DETECTORS

HIGH POWER SOLUTIONS

PHOTO DETECTORS

THZ DETECTORS

OEM DETECTORS

SPECIAL PRODUCTS

BEAM DIAGNOSTICS



## OPTICAL TRAP DETECTORS

### Don't Lose Your Photons Anymore.

The TRAP detectors have the Highest Efficiency Detectors in the Photonics World with a Quantum efficiency (QE)  $\gg 99\%$ . They also present incredible spatial uniformity, better than  $0.02\%$ . Their high QE and low calibration uncertainty ( $< 0.5\%$ ) make them an excellent, standalone, calibration transfer standard. Heads are optimized for both CW or Pulsed Lasers and can be used for low divergence or collimated beams. Measure power from pW to mW when used with the TRAP-PREAMP amplifier that provides a direct digital readout.

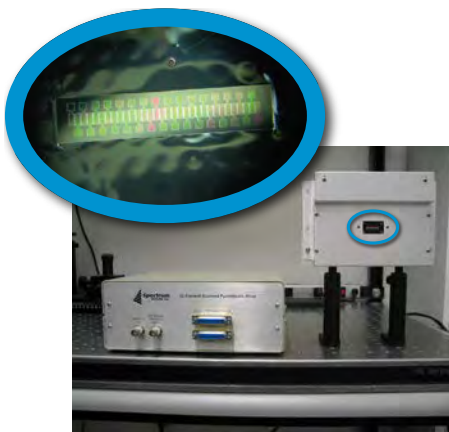

## 32-CHANNEL THZ PYROELECTRIC ARRAY

The SDX-1105 is a 32-element Pyroelectric Array combined to a 32-channel multiplexing electronics that was designed for a THz Spectrometer Application. The system was designed to be able to measure a few nanojoules of energy from a pulsed THz source in the 0.1 to 20 THz region. As the Pyroelectric detectors are based on a thermal effect, the same device can be used with pulsed lasers from the DUV to FIR. The detector elements of the array are 1 mm tall by 0.5 mm wide and spaced on 0.5 mm centers.

## TEMPERATURE-CONTROLLED POWER METERS

### Temperature Controlled Power Sensors and Controller:

Each head is composed of a low noise detector, thermistor, TE cooler and heat sink to compensate for any temperature change

### The Ultimate Choice in Measurement Stability:

Temperature control down to  $0.05^{\circ}\text{C}$  from  $20$  to  $30^{\circ}\text{C}$  gives a temperature coefficient  $< 0.01\%$ , thus a voltage output stable to  $0.01\%$

### 2 Sizes Available for the TP Sensors:

- TP5-BL: 5 mm  $\varnothing$  pyroelectric sensor with organic black coating
- TP9-BL: 9 mm  $\varnothing$  pyroelectric sensor with organic black coating



# CUSTOM PRODUCTS



## PULSE BURST ENERGY METER

This pulse burst energy meter was developed for Candela Corporation for a new 2-Color Medical Laser System that required measuring the power in multiple pulses and displaying total and sub-pulse energy and pulse width of a laser running in a burst mode.

It was designed to measure a single pulse or up to eight pulses in a burst. The spectral range was 0.5  $\mu\text{m}$  to 3.0  $\mu\text{m}$ .

- MEASURES INDIVIDUAL PULSE ENERGIES IN A PULSE BURST

## 10-CHANNEL ENERGY METER

This Energy Meter was designed for use with Mid-IR and Far-IR lasers and could be used in pairs to create a 10-Channel Digital Joulemeter. The energy sensors were based on fast Pyroelectric Detectors outfitted with KRS5 windows. The microprocessor instrument featured a full speed USB2.0 output, LabView application software and USB Drivers. It also included a multiplexed analog output for use with an oscilloscope that allowed viewing of the relative energy of each channel.

- COMBINES 10 ENERGY MEASUREMENTS IN ONE APPLICATION



## “HOLLOW” DETECTOR

This special calorimeter demonstrates the extent of Gentec-EO's customization capabilities. This product fulfills the requirements for the newest lasers for high energetic beam experimentation.

- High energy at low repetition rate for continuous measurement
- Femtosecond pulse
- Very large diameter with different shapes & sizes available
- Offers the flexibility to measure both power or energy
- Center hole option for let through an electron beam

- SHORT PULSES, HIGH ENERGIES
- VARIOUS SHAPES & SIZES



# CALORIMETERS



Photo courtesy of Lawrence Livermore National Laboratory

A Gentec-EO calorimeter is the only reliable solution available for the largest and highest energy laser beams. Through cooperation with several leading research facilities around the world, Gentec-EO has become the expert in manufacturing, calibrating and servicing calorimeters for use in high energy inertial confinement fusion calorimetric measurement.

# PRESENTATION



## STATE-OF-THE-ART

We work with a wide range of materials from surface coatings to the most robust volume absorbers to provide the best solution for your specific application.

- OUTSTANDING SIGNAL TO NOISE RATIOS
- HIGH SENSITIVITY
- VACUUM COMPATIBILITY
- ATTENTION TO DETAIL AND WORKMANSHIP

gained over 40 years of experience in thermal-based energy measurement make Gentec-EO the ideal choice for all your high energy measurement needs.

## ACCURATE

Using NIST traceable sources and proven calibration techniques, your Gentec-EO calorimeter is always the most accurate large aperture measurement device on the market.

With calibration uncertainties of  $\pm 3\%$ , and repeatabilities better than  $\pm 2\%$  for very large beams, Gentec-EO offers the very best solution for extreme energy measurement and for balancing in multi laser systems.



## CUSTOMIZED

We have designed calorimeters for 16 kJ beams. We have built them for beams as large as 420 x 427 mm in aperture size, to withstand pulse energy densities of more than 15 J/cm<sup>2</sup>.

We have also provided highly sensitive, large-aperture size calorimeters for beam energies as low as 50 mJ for the most delicate applications.

Our calorimeters span the band from 190 nm to 25 microns. Moreover, we are happy to push these limits even further. We work with a wide range of materials from surface coatings to the most robust volume absorbers to provide the best solution for your specific application.



# APPLICATIONS

## LASER FUSION EXPERIMENTS

Inertial confinement fusion (ICF) is a process where nuclear fusion reactions are initiated by heating and compressing a fuel target, typically in the form of a pellet that most often contains a mixture of deuterium and tritium. To compress and heat the fuel, energy is delivered to the outer layer of the target using high-energy beams of laser light.\* ICF is said to reproduce the energy generation process taking place in the core of the sun.

Several laser fusion projects are underway around the world right now, their main goal is to produce a clean, reliable and nearly unlimited source of energy. All these laser fusion experiments use very high energy lasers of several kJ per pulse for which a Gentec-EO calorimeter is the ONLY reliable measuring device available on the market. Over the years, we have been presented with increasingly large and energetic laser pulses to be measured and we have kept pace with the world's most demanding lasers.

\* Source: Wikipedia.

## LASER FUSION MECHANISM

Schematic of the stages of inertial confinement fusion using lasers. The blue arrows represent radiation; orange is blowoff; purple is inwardly transported thermal energy.

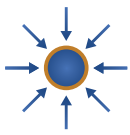

1.

Laser beams or laser-produced X-rays rapidly heat the surface of the fusion target, forming a surrounding plasma envelope.

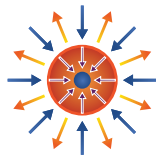

2.

Fuel is compressed by the rocket-like blowoff of the hot surface material.

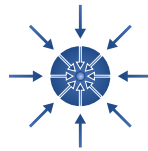

3.

During the final part of the capsule implosion, the fuel core reaches 20 times the density of lead and ignites at 100,000,000 °C.



4.

Thermonuclear burn spreads rapidly through the compressed fuel, yielding many times the input energy.

Typical pulse values for these lasers are in the range:

Aperture Sizes:  
Up to 420 x 427 mm

Energy Range:  
Up to 16 kJ

Pulse Widths:  
Nanoseconds

Wavelengths:  
From UV to NIR

## FEMTOSECOND LASERS

Femtosecond lasers are developing at a very fast pace. Some lasers now feature peak powers in the Petawatts ( $10^{15}$  W). Furthermore, the beam sizes can be fairly small, which results in peak power densities too high for a standard detector. Typically, pulse values for these lasers are in the range:

**Beam Sizes:** Up to 160 mm Ø

**Energy range:** 1 J to 100 J

**Pulse Widths:** Femto & picosecond

**Wavelengths:** UV to NIR

For these, a Gentec-EO calorimeter is the only reliable solution. Furthermore, it can sometimes be used in power meter mode.

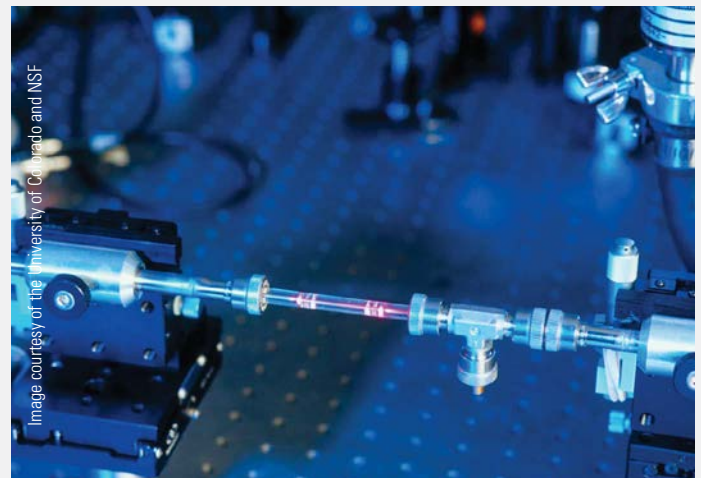

Image courtesy of the University of Colorado and NSF

# TECHNICAL ASPECTS

## EXAMPLES OF CUSTOM CALORIMETERS

MAIN SPECIFICATIONS	SPECTRAL RANGE	MINIMUM ENERGY	MAXIMUM ENERGY
<b>RECTANGULAR APERTURES</b>			
420 x 427 mm	1053 nm	500 J	16 000 J
420 x 427 mm	351/532/1053 nm	200 J	5 000 J
110 x 110 mm	351/532/1053 nm	1 J	50 J
400 x 400 mm	351/532/1053 nm	200 J	5 000 J
230 x 230 mm	532/1064 nm	100 J	1 500 J
<b>ROUND APERTURES</b>			
310 mm Ø	351 nm	20 J	500 J
310 mm Ø	0.35 - 1.1 µm	200 J	1 500 J
150 mm Ø	0.3 - 1.1 µm	1 J	500 J
50 mm Ø	0.19 - 10 µm	15 mJ	200 J
19 mm Ø	0.19 - 25 µm	1 mJ	2.3 J
17 mm Ø	0.19 - 10 µm	1 mJ	23 J

## MONITORING

### MONITOR



Dual Channel (up to 4 on request)  
Power & Energy PC-Based (USB or Ethernet)

### S-LINK & P-LINK

The P-LINK and S-LINK are PC-Based power and energy monitors. The S-LINK comes with 1 or 2 channels and the P-LINK with 1 or 4 channels. They are the perfect choice to be integrated into your system and used remotely. You have the choice between USB, RS-232 or Ethernet connection and both come with a complete acquisition software.

See pages **28 & 30**.

### ACQUISITION SOFTWARE

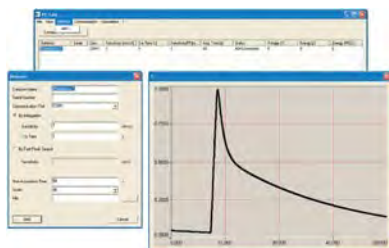

Can handle several calorimeters Saves Data to the PC Graphic Display

### PC-CALO

The PC-Calo is a user-friendly PC interface that reads and controls several channels simultaneously via a USB or Ethernet connection. It reads the voltage outputs of the S-LINK, saves the data in a spreadsheet, displays the data graphically and analyzes the measured energy. The parameters are entered separately and the data can be treated individually or simultaneously.

### REMOTE SYSTEM DIAGNOSTIC



Validation of the Calibration  
Verification of the Signal Response

### RSD

Do the on-site monitoring of your calorimeter using our special diagnostic tool. The verification is done remotely so you can control it from another location. The diagnostic includes the verification of the calorimeter's calibration and of the signal response and data acquisition.

# TECHNICAL DRAWINGS

All dimensions in mm

## M5/M6 (6 mm Ø)

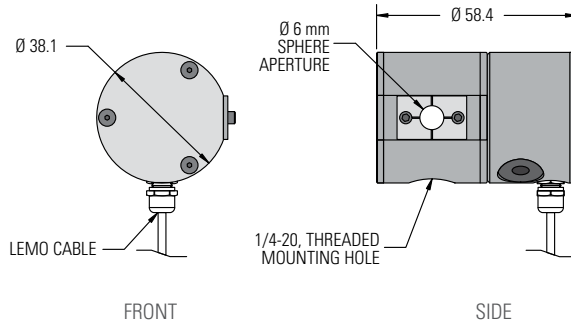

View

FRONT

SIDE

## M5/M6 (12,5 mm Ø)

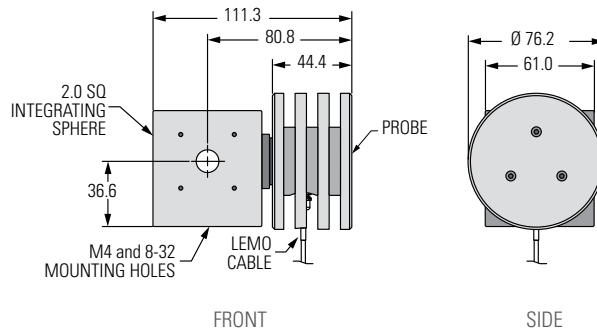

View

FRONT

SIDE

## QS (TO5-BASED)

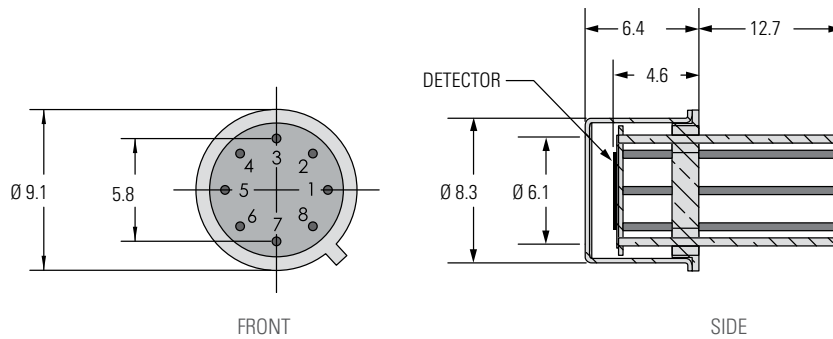

View

FRONT

SIDE

## QS (TO8-BASED)

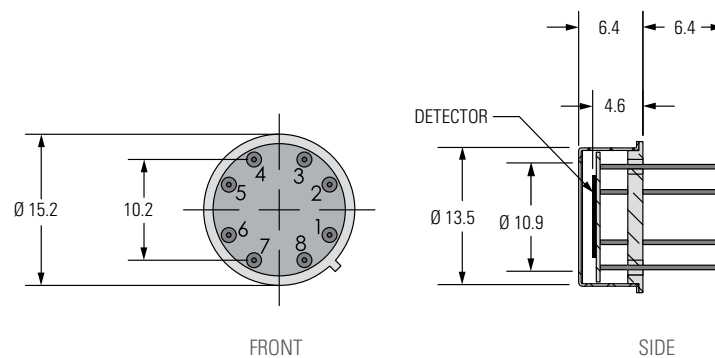

View

FRONT

SIDE

MONITORS  
ENERGY DETECTORS  
POWER DETECTORS  
HIGH POWER SOLUTIONS  
PHOTO DETECTORS  
THZ DETECTORS  
OEM DETECTORS  
SPECIAL PRODUCTS  
BEAM DIAGNOSTICS

# ABSORPTION CURVES

## QUAD

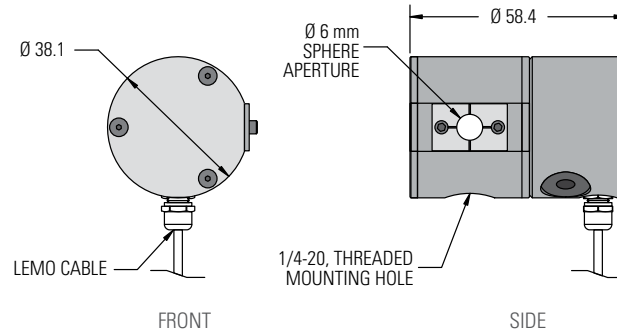

View

## TRAP

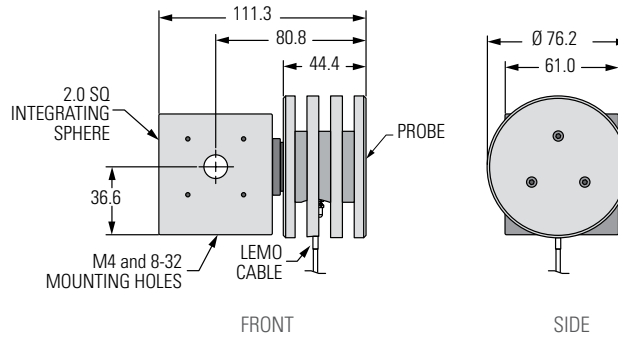

View

## M5/M6-Si & M5/M6-In

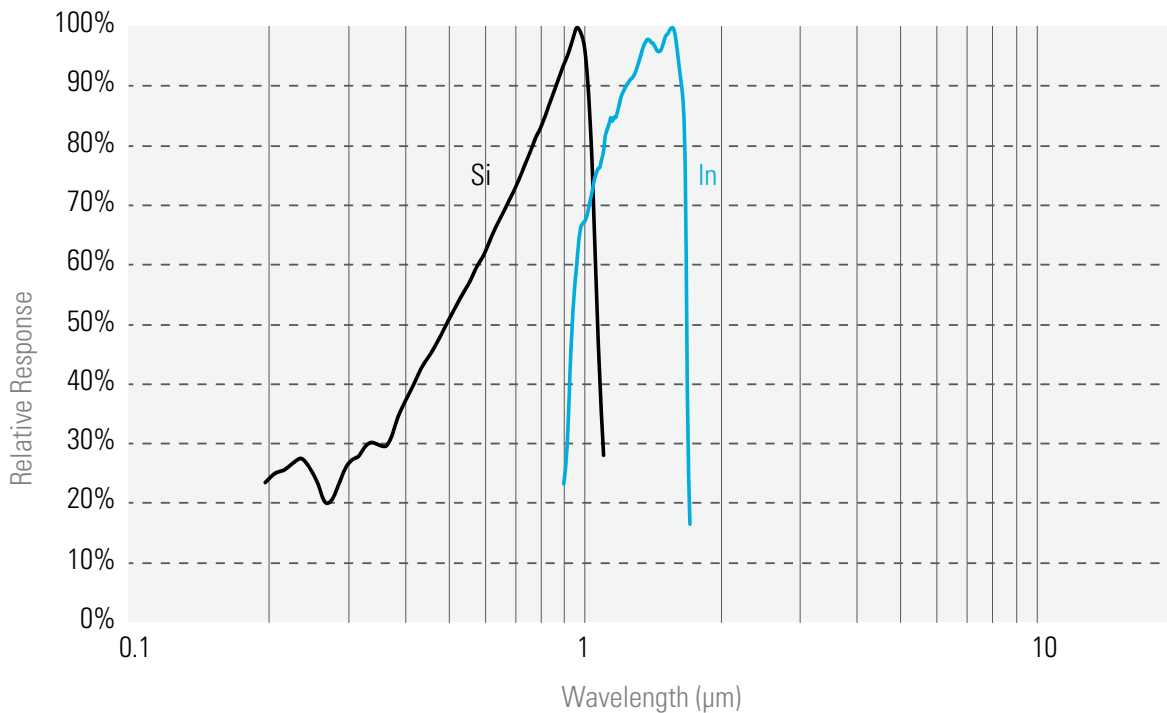

# CAMERAS

## PRESENTATION



### BEAM PROFILING CAMERAS

Profiling a laser beam is a convenient complement to the measurement of its power or energy because it provides very useful additional information, like spatial energy or intensity distribution, beam widths, centroid, ellipticity and orientation, that may help you determine if your laser-based systems are operating optimally.

The Beamage is the most cost-effective USB3.0 Beam Profiling Camera on the market. It is available for UV to IR wavelengths and in 2 sizes. It comes with an intuitive and complete software that features an array of useful tools and functions. Its calculations are ISO compliant.

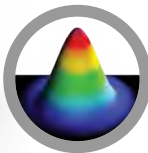

See page 172

## MAIN SPECIFICATIONS

	BEAMAGE-3.0	BEAMAGE-3.0-IR	BEAMAGE-4M
Wavelength Range			
Camera only	350 - 1150 nm	1495 - 1595 nm	350 - 1150 nm
With UG11-UV Filter	250 - 370 nm	---	250 - 370 nm
With B3-IR-Filter	1250 - 1350 nm	---	1250 - 1350 nm
Pixel Count	2.2 MPixels	2.2 MPixels	4.2 MPixels
H x V	2048 x 1088	2048 x 1088	2048 x 2048
Sensor Size	11.3 x 6.0 mm	11.3 x 6.0 mm	11.3 x 11.3 mm
Frame Rate (Full Frame)	8 fps	8 fps	6.2 fps



IF YOUR  
**LASER SPECIFICATIONS**  
**EXCEED THE LIMITS IN**  
TERMS OF

**WAVELENGTH**

**BEAM SIZE**

**LASER POWER**

YOU CAN MANAGE THEM WITH ACCESSORIES PRESENTED ON THE NEXT PAGE.

# ACCESSORIES

## PRESENTATION

### MANAGE THE WAVELENGTH

See page **178**

Since CMOS sensors are not sensitive to every frequency of the electromagnetic spectrum, we offer several wavelength management solutions to enhance the capabilities of the Beamage Beam Profiling Cameras.

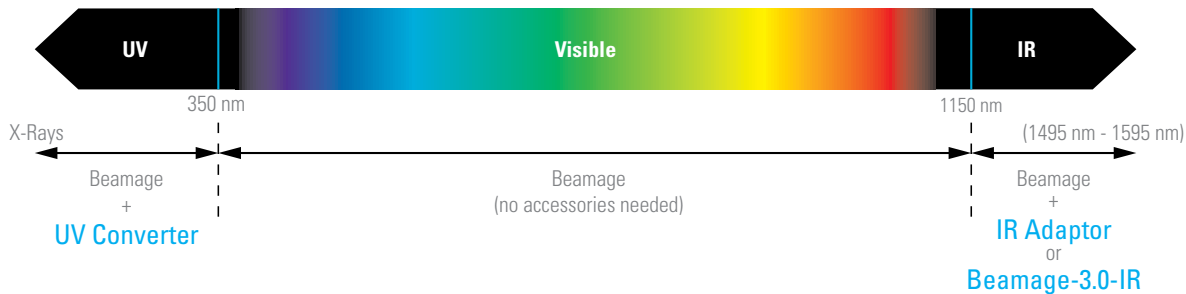

### MANAGE THE BEAM SIZE

See page **181**

A simple solution is offered to those who need to profile beams that are larger than the CMOS sensor (> 11.3 mm x 6.0 mm). This solution is a beam reducing optical component called Camera Lens. It works by indirectly imaging the reflection or transmission of the beam after it has passed through a diffusing element.

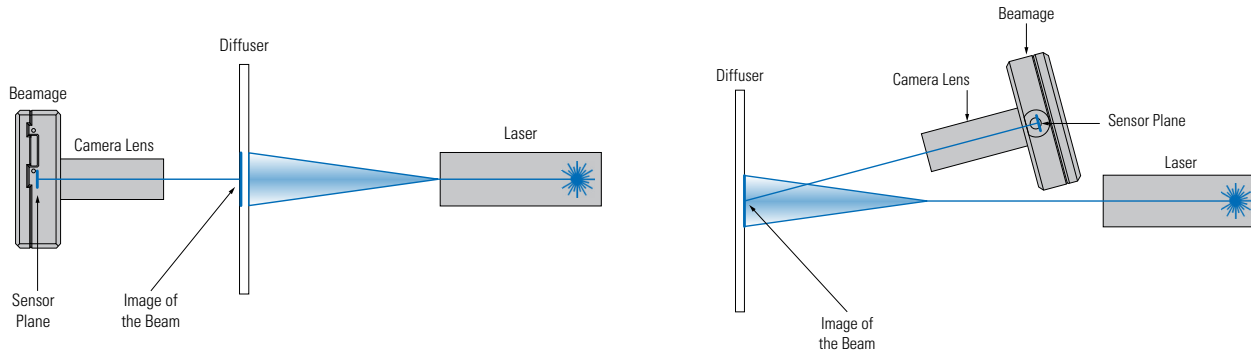

### MANAGE THE LASER POWER

See page **182**

CMOS sensors have low saturation levels as well as low damage thresholds. It is thus very important that you control your laser power to get the best measurement possible and avoid damaging the Beamage camera.

**UP TO 1 W**

<p><b>ND, UV and IR Filters</b></p> 	<p><b>Variable Attenuator</b></p> 
---	---

**1 W TO 40 W**

<p><b>Beam Splitter Cube</b></p> 	<p><b>Beam Sampler</b></p> 
---	--

# BEAMAGE

CMOS Beam Profiling Cameras

MONITORS

ENERGY DETECTORS

POWER DETECTORS

HIGH POWER SOLUTIONS

PHOTO DETECTORS

THZ DETECTORS

OEM DETECTORS

SPECIAL PRODUCTS

BEAM DIAGNOSTICS



## KEY FEATURES

- 1. USB 3.0 FOR THE FASTEST TRANSFER RATES**  
Up to 10X faster than regular USB 2.0 connections (also USB 2.0 compatible)
- 2. HIGH RESOLUTION**  
2.2 MPixels resolution gives accurate profile measurements of very small beams
- 3. LARGE AREA SENSORS**
  - 11.3 x 6.0 mm for the Beamage-3.0
  - 11.3 x 11.3 mm for the Beamage-4M, double the size of the Beamage-3.0!
- 4. AVAILABLE WITH IR COATING**  
Beamage-3.0-IR has a special Phosphor coating for IR wavelengths (1495-1595 nm)
- 5. ISO COMPLIANT**  
D4σ Definition of Diameter, Centroid, Ellipticity and Orientation are ISO 11146:2004 and 11146:2005 compliant
- 6. INTUITIVE SOFTWARE INTERFACE**  
Easy to navigate interface, with many displays and control features:
  - 2D, 3D and XY Displays
  - Background Subtraction Function
  - Unique “Animate” Function
  - Gaussian Fit
  - Semi-Log Graph
- 7. EXTERNAL TRIGGER**  
To synchronize the camera with a pulsed laser

## AVAILABLE MODELS



Beamage-3.0 et Beamage-3.0-IR  
(11.3 X 6.0 mm)



Beamage-4M  
(11.3 X 11.3 mm)

## MAIN FUNCTIONS



Beam Tracking



Filters



Divergence



Subtract Background



Animate



Normalize



Image Averaging



Trigger

## ACCESSORIES



Stand with Delrin Post  
(Model Number: 200428)



BDA-A-VAR, BDA-S-10-UV/IR  
Beam Splitters and Attenuators



Stackable ND Filters  
(0.5, 1.0, 2.0, 3.0, 4.0 & 5.0)



UV and IR Filters



UV Converters &  
IR Adaptors



Pelican Carrying Case

## SEE ALSO

- ACCESSORIES FOR BEAM DIAGNOSTICS **178**
- LIST OF REGULAR ACCESSORIES **184**

### APPLICATION NOTE

- HOW TO CHOOSE A UV CONVERTER **202182**

# BEAMAGE

## SPECIFICATIONS

	BEAMAGE-3.0	BEAMAGE-3.0-IR	<b>NEW</b> BEAMAGE-4M
<b>SENSOR TECHNOLOGY</b>	CMOS	CMOS (with Phosphor Coating)	CMOS
<b>EFFECTIVE APERTURE</b>	11.3 x 6.0 mm	11.3 x 6.0 mm	11.3 x 11.3 mm
<b>MEASUREMENT CAPABILITY</b>			
Wavelength Range			
Camera only	350 - 1150 nm	1495 - 1595 nm	350 - 1150 nm
With UG11-UV Filter	250 - 370 nm	---	250 - 370 nm
With B3-IR-FILTER	1250 - 1350 nm	---	1250 - 1350 nm
Pixel Count	2.2 MPixels	2.2 MPixels	4.2 MPixels
H x V	2048 x 1088	2048 x 1088	2048 x 2048
Pixel Dimension	5.5 x 5.5 $\mu$ m	5.5 x 5.5 $\mu$ m	5.5 x 5.5 $\mu$ m
Minimum Measurable Beam	55 $\mu$ m	70 $\mu$ m <sup>b</sup>	55 $\mu$ m
Shutter Type	Global	Global	Global
Frame Rate	---	---	6.2 fps @ 4.2 MPixels (Full Frame)
	8 fps @ 2.2 MPixels (Full Frame)	8 fps @ 2.2 MPixels (Full Frame)	11.4 fps @ 2.2 MPixels (Full Frame)
	15 fps @ 1.1 MPixels (2048 x 544)	15 fps @ 1.1 MPixels (2048 x 544)	18.6 fps @ 1.1 MPixels (2048 x 544)
	32 fps @ 0.066 MPixels (256 x 256)	32 fps @ 0.066 MPixels (256 x 256)	32 fps @ 0.066 MPixels (256 x 256)
RMS Noise	1000:1 (60 dB)	1000:1 (60 dB)	1000:1 (60 dB)
ADC Level (User Setable)	12 bit (default) / 10 bit (option)	12 bit (default) / 10 bit (option)	12 bit (default) / 10 bit (option)
<b>DAMAGE THRESHOLDS <sup>a</sup></b>			
Maximum Average Power	1 W		
Saturation Level (1064 nm)	CW: 10 W/cm <sup>2</sup> ; Pulsed: 300 $\mu$ J/cm <sup>2</sup>		
<b>SOFTWARE</b>			
Displays	2D, 3D, XY and Beam Tracking		
Display Features	2D: Print Screen, Reset View, Show/Hide Beam Diameter 3D: Print Screen, Reset View, Top View XY: Save Data, Zoom, Gaussian Fit, Semi-Log, Show/Hide Cursor, Show/Hide FWHM, Show/Hide 1/e <sup>2</sup> Beam Tracking: Save Data, Print Screen, Reset View, Zoom		
Beam Diameter Definitions	D4 $\sigma$ (ISO compliant) 1/e <sup>2</sup> along crosshairs (13.5%) FWHM along crosshairs (50%) 86% effective diameter (D86)		
Buffer Controls	Open File, Save Current Data, Save All Data, Previous/Next Image, Clear Buffer, Animate		
Printing and Reports	Full Report in Print Ready Format (2D, 3D, XY, Measures, Parameters) Print Screen in BMP format (2D and 3D)		
<b>PHYSICAL CHARACTERISTICS</b>			
Sensor Size	11.3 x 6.0 mm	11.3 x 6.0 mm	11.3 x 11.3 mm
Sensor Area	0.67 cm <sup>2</sup>	0.67 cm <sup>2</sup>	1.28 cm <sup>2</sup>
Dimensions (not including filter)	61H x 81.1W x 19.7D mm		
Weight (head only)	138 g		
<b>ORDERING INFORMATION</b>			
Product Name	Beamage-3.0	Beamage-3.0-IR	Beamage-4M
Product Number	201939	202360	202880

Specifications are subject to change without notice

a. With ND4 filter

b. Minimum measurable beam is larger because of the Point Spread Function (PSF) of the Phosphor coating.

# BEAMAGE

## INTUITIVE SOFTWARE INTERFACE

### Capture Controls:

Start/Stop,  
Subtract Background

Buffer Controls:  
View Data Offline

Data  
Computation

File Controls:  
Save and Open Data

Startup Configuration:  
Save and Load Settings

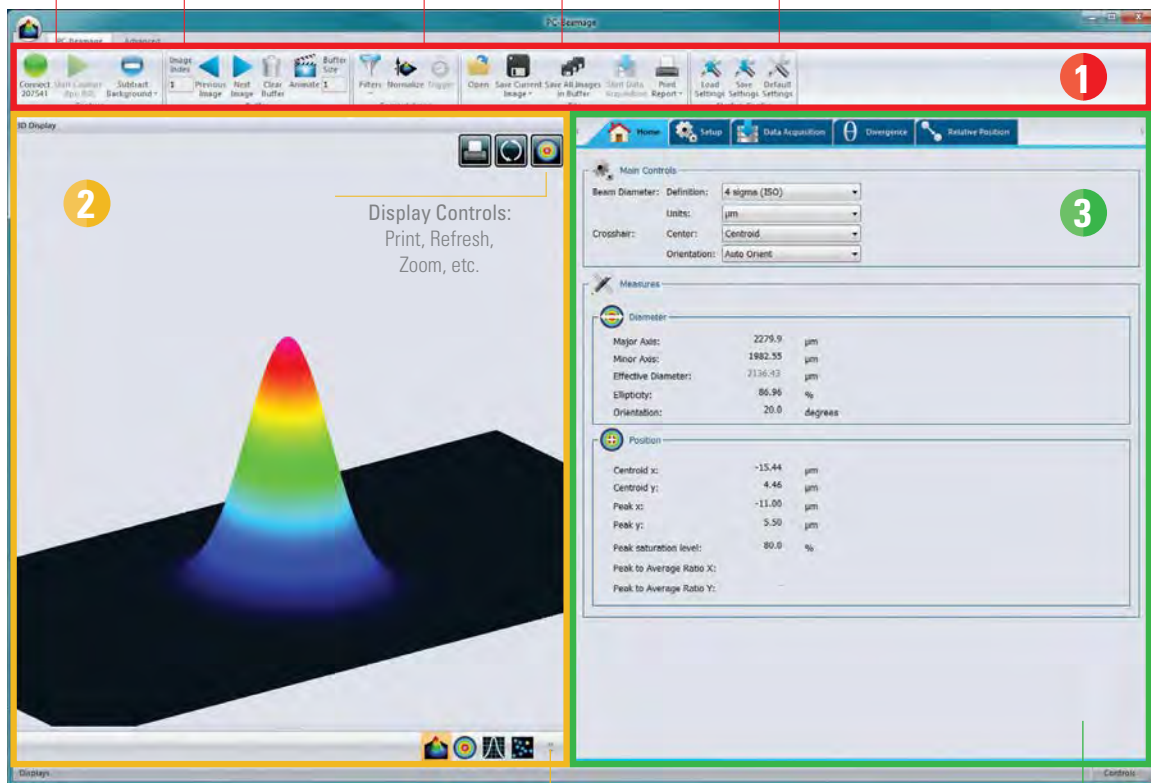

Displays:  
3D, 2D, XY Graphs and Beam Tracking

Home, Setup and Acquisition Tabs:  
Set your capture parameters and get the resulting measures

## 1 MAIN CONTROLS

The upper part of the software includes all the main controls in a ribbon format. These controls are grouped by family: Capture Controls, File Controls, Buffer Controls, M2 Controls and Data Computations. The last includes very useful filters and a normalizing function.

## 2 DISPLAYS

The left-hand side of the software is the display panel. Four displays are available: 3D, 2D, XY (cross-sectional graphs along the crosshairs) and Beam Tracking. The desired display is selected by clicking on the corresponding icon at the bottom of the panel. Print screen controls are available for the 3D, 2D and Beam Tracking displays. They allow the user to save an image of the current view in BMP format.

## 3 HOME AND SETUP TABS

The right-hand side of the software contains the Home, Setup and Data Acquisition tabs. The Home tab allows the user to select the main controls for his measurements (Beam Diameter Definition, Crosshair Center and Orientation) and displays the resulting measurements below. The Setup tab allows the user to set the measurement parameters (Exposure Time, Image Orientation and Averaging, Active Area, etc.) and the Data Acquisition tab allows the user to save measurements or measurements and full images, to enter the Sampling Rates and a Total Duration for the Acquisition. More tabs with advanced controls are available when clicking on the Show/Hide Options button in the Computations panel.

# BEAMAGE

## 3D, 2D AND XY DISPLAYS

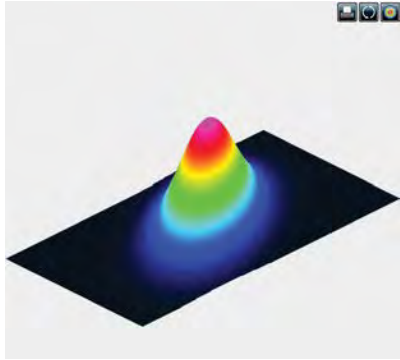

### 3D DISPLAY

The 3D display shows the actual shape of the beam. It is possible to easily zoom, pan and rotate the image. The very useful Reset button allows to put the data back in its original configuration. This display also features a Print Screen button to save the latest image in BMP format.

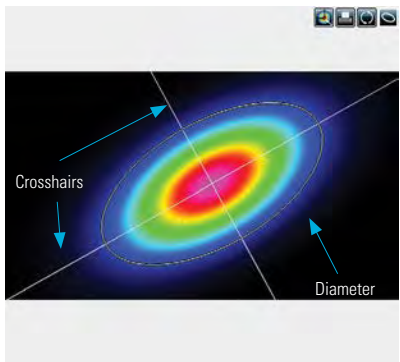

### 2D DISPLAY

The 2D display features the crosshairs (set to the major and minor axis or along specified angles) and the measured diameters of the beam. These diameters vary with the chosen definition (4-sigma, FWHM,  $1/e^2$ , etc.) and the display can be turned ON or OFF. The Print Screen button allows to save a picture of the current screen in BMP format.

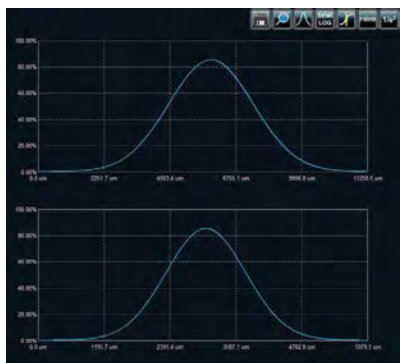

### XY DISPLAY

The XY display plots cross-sectional graphs of the beam along the crosshairs. This display features many useful tools like zoom, cursor, and FWHM and  $1/e^2$  level bars. It is also possible to display the graphs in semi-log format to enhance the details in the low intensity parts of the beam.

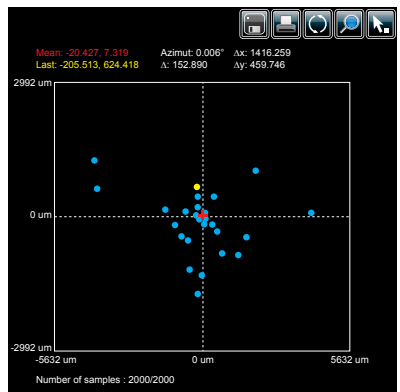
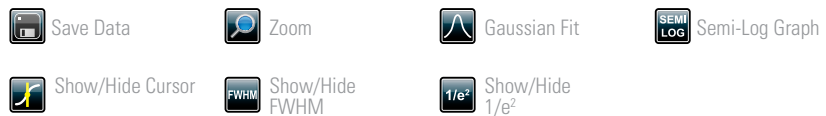

### BEAM TRACKING DISPLAY

The Beam Tracking Display allows the user to visualize the variation of the beam's centroid position on the sensor. This display shows the latest calculated position as well as the previous ones, until the user resets the view. The display also shows the mean position of all computed values and gives information regarding position stability for both X and Y axes. This tool is great to monitor the beam pointing stability over time.

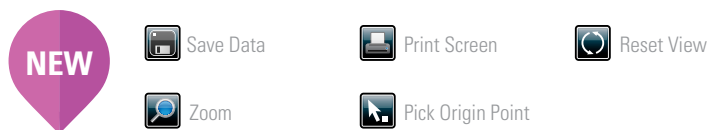

# BEAMAGE

## MAIN FUNCTIONS

MONITORS

ENERGY DETECTORS

POWER DETECTORS

HIGH POWER SOLUTIONS

PHOTO DETECTORS

THZ DETECTORS

OEM DETECTORS

SPECIAL PRODUCTS

BEAM DIAGNOSTICS

### FILTERS



Filter out the noise in your beam profile by using one of the filter functions. The Beamage has both smoothing and despeckle filters. The Smoothing filter is a soft noise reduction method whereas the Despeckle filter is a much more aggressive spatial filter that is designed to remove speckles and noisy signals from very poor quality beam profiles. Instead of performing a 3x3 pixel smoothing filter with a relative weight of 20% for the central pixel and 10% for the others, the software performs a 9x9 pixels simple averaging, with all pixels having the same relative weight (1/81). The filter can be found in the Filters menu of the main controls.

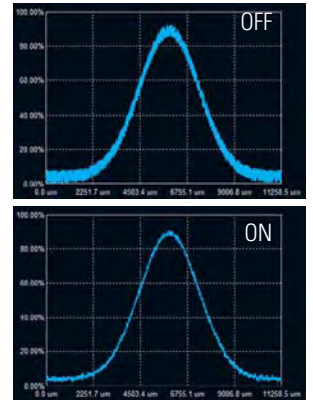

### DIVERGENCE



The Divergence of a beam is defined as the increase in beam radius with propagation from the optical aperture. For most applications, a lower-divergence beam is preferable. Using the new Divergence tab in the PC-Beamage application, this parameter can now be computed for both mains axes (X, Y) according to the ISO 11146-1:2005 and 11146-2:2005 standards. A focal lens with a known focal length is required for the measurement of the divergence.

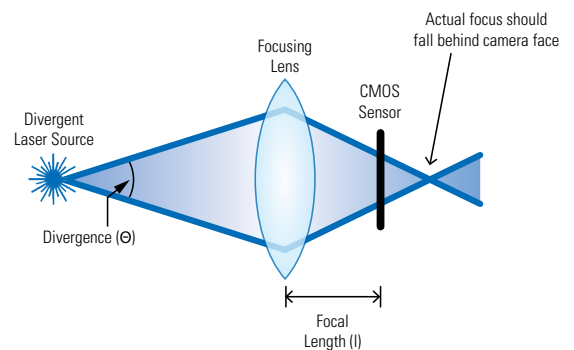

### ACQUISITION



In the Acquisition tab, the user can define a total duration for the acquisition and can specify a name and a path for his saved files. The user can either choose to save measurements only or both measurements and full images. It is possible to save the data shown in the measure tab in a \*.TXT file, which includes a header that displays the custom acquisition settings above the data. Each line corresponds to a single frame. This file can be opened in a spreadsheet software such as Microsoft Excel. It is also possible to save the images associated with the measurements from the \*.TXT logging file. Each image will be individually saved in a native \*.BMG file. For measurements, it is possible to choose a sampling rate for the saved data. Similarly, for the full images, one can manually set a temporal interval at which the software will save the data. With these tools, the user will be able to store only the information that is useful to his work.

### RELATIVE POSITION



In the "Relative Position" tab, the "Setup" section allows the user to select the parameter that will be considered as the origin position (0,0). "Centroid" (center of energy) and "Peak" (highest measured value) are the options. The "User Define" option allows the user to manually enter origin position values for both axes. It is also possible to position the origin by simply clicking with the mouse in the display. Once the origin position is determined by the user, the software calculates the difference between the coordinates of this new position and the latest computed one. The results are displayed in the "Measures" section. It is possible to save the data in the acquisition file if desired.

# BEAMAGE

## MAIN FUNCTIONS

### SUBTRACT BACKGROUND



The background subtraction function is a necessary tool to have an accurate measurement and to abide by the ISO 11146-3:2004 standards. By taking 10 images and averaging them pixel by pixel to compute the average background map, contamination of all images can be avoided with the help of environment noise subtraction.

### ANIMATE



Give life to your measures with the animate function. With as much as 32 images temporarily saved in the buffer, simply pressing the animation button will create a movie with any display (2D, 3D and XY). This allows to visualize the beam while working offline and to have a recalculation process if the beam diameter definition or crosshair parameters are changed.

### MULTIPLE CAMERAS



It is possible to use multiple Beamage cameras on one computer simultaneously. By running multiple PC-Beamage instances and selecting the desired camera for each one, the user will be able to stream multiple cameras simultaneously, thus effectively monitoring all the beams and easily switching from one to another.

### NORMALIZE



The normalize function spreads the intensity over the full range (0% to 100%). This is especially useful with low level signals or to enhance the variations in the beam.

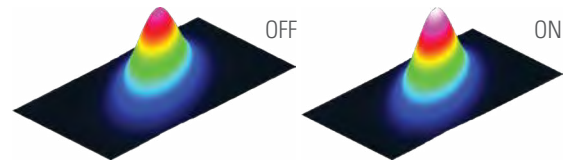

### TRIGGER



For the case of pulsed laser sources, the trigger function will be useful to synchronize the system's capture rate with the source's repetition rate, especially when this one is low (<16 Hz). To be achieved, a TTL (0-5 V) or other (1.1-24 V) trigger signal can be connected to the Beamage camera via a BNC or SMA plug.

### IMAGE AVERAGING



The image averaging function uses a temporal filter that captures 2, 5 or as much as 10 images of the beam to create a single time-averaged image with them. This process will smooth the beam fluctuations that can occur over time when working with unstable laser sources.

### ACTIVE AREA (ROI)



Increase the data transfer rate by reducing the area of the sensor that is scanned. This tool is perfect for small beams that don't need the full sensor area.



### PIXEL ADDRESSING



Increase the data transfer rate by using larger pixels or by reducing the number of pixels. This is great for large beams that don't need the full resolution.

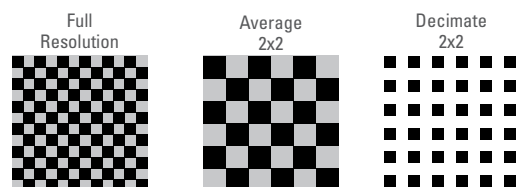

# WAVELENGTH MANAGEMENT

## UV CONVERTERS

UV Converters take advantage of a phenomenon called fluorescence to extend the performance range of the Beamage beam profiling camera to ultraviolet wavelengths. A fluorescent crystal located at the entrance of the converter absorbs UV wavelengths and reemits longer wavelengths (in the visible spectrum), which are less energetic and detected by the CMOS sensor.

### MAIN CHARACTERISTIC

- Transforms wavelengths contained between X-Rays and 400 nm to visible and near-IR wavelengths.
- Images larger beams due to the magnification properties of the optics.
- Built with an iris at the output port for a control of the exposure on the CMOS sensor.
- Removable extension tube that is easily fixed onto the entrance port of the Beamage camera.
- Ready to use within minutes



### SPECIFICATIONS

MODEL	BSF12C12N	BSF12C23N	BSF12P12N	BSF12P23N	BSF12R12N	BSF12R23N	BSF12G12N	BSF12G23N
Input Aperture Ø	12 mm	12 mm	12 mm	12 mm	12 mm	12 mm	12 mm	12 mm
Closest Standard Optical Camera Format	1/2"	2/3"	1/2"	2/3"	1/2"	2/3"	1/2"	2/3"
Main Tube Length (L)	60 mm	60 mm	60 mm	60 mm	60 mm	60 mm	60 mm	60 mm
Extension Tube Length (D)	24.3 mm	29.2 mm	24.3 mm	29.2 mm	24.3 mm	29.2 mm	24.3 mm	29.2 mm
Overall Length (OAL)	102.8 mm	109.7 mm	102.8 mm	109.7 mm	102.8 mm	109.7 mm	102.8 mm	109.7 mm
Max Input Beam Size	7.2 x 9.6 mm	7.2 x 9.6 mm	7.2 x 9.6 mm	7.2 x 9.6 mm	7.2 x 9.6 mm	7.2 x 9.6 mm	7.2 x 9.6 mm	7.2 x 9.6 mm
Max Beam Size on CMOS	4.2 x 5.6 mm	6.0 x 8.0 mm	4.2 x 5.6 mm	6.0 x 8.0 mm	4.2 x 5.6 mm	6.0 x 8.0 mm	4.2 x 5.6 mm	6.0 x 8.0 mm
Magnification	1.7	1.2	1.7	1.2	1.7	1.2	1.7	1.2
Crystal Type	C	C	P	P	R	R	G	G
Wavelength Range	110 - 225nm	110 - 225 nm	110 - 350 nm	110 - 350 nm	110 - 535 nm	110 - 535 nm	X-ray - 400 nm	X-ray - 400 nm
Relative Response	193 nm 248 nm 308 nm	22 0.17 0.03	48 15 1	48 15 1	100 8 0.18	100 8 0.18	480 480 112	480 480 112
Saturation Level	193 nm 248 nm 308 nm	400 mJ/cm <sup>2</sup> N/A N/A	400 mJ/cm <sup>2</sup> N/A N/A	30 mJ/cm <sup>2</sup> 30 mJ/cm <sup>2</sup> 50 mJ/cm <sup>2</sup>	30 mJ/cm <sup>2</sup> 30 mJ/cm <sup>2</sup> 50 mJ/cm <sup>2</sup>	50 mJ/cm <sup>2</sup> 400 mJ/cm <sup>2</sup> 400 mJ/cm <sup>2</sup>	50 mJ/cm <sup>2</sup> 400 mJ/cm <sup>2</sup> 400 mJ/cm <sup>2</sup>	10 mJ/cm <sup>2</sup> 10 mJ/cm <sup>2</sup> 50 mJ/cm <sup>2</sup>
Decay Time		3 - 5 µs	3 - 5 µs	5 µs	5 µs	3000 µs	3000 µs	0.5 µs
Max Repetition Rate		30 - 20 kHz	30 - 20 kHz	20 kHz	20 kHz	30 Hz	30 Hz	200 kHz
Product Number		202314	202315	202318	202319	202320	202323	202316

MODEL	BSF23C12N	BSF23C23N	BSF23P12N	BSF23P23N	BSF23R12N	BSF23R23N	BSF23G12N	BSF23G23N
Input Aperture Ø	23 mm	23 mm	23 mm	23 mm	23 mm	23 mm	23 mm	23 mm
Closest Standard Optical Camera Format	1/2"	2/3"	1/2"	2/3"	1/2"	2/3"	1/2"	2/3"
Main Tube Length (L)	76.3 mm	76.3 mm	76.3 mm	76.3 mm	76.3 mm	76.3 mm	76.3 mm	76.3 mm
Extension Tube Length (D)	27.4 mm	30 mm	27.4 mm	30 mm	27.4 mm	30 mm	27.4 mm	30 mm
Overall Length (OAL)	118.2 mm	124.8 mm	118.2 mm	124.8 mm	118.2 mm	124.8 mm	118.2 mm	124.8 mm
Max Input Beam Size	13.8 x 18.4 mm	12.5 x 18.4 mm	13.8 x 18.4 mm	12.5 x 18.4 mm	13.8 x 18.4 mm	12.5 x 18.4 mm	13.8 x 18.4 mm	12.5 x 18.4 mm
Max Beam Size on CMOS	4.6 x 6.1 mm	6.0 x 8.8 mm	4.6 x 6.1 mm	6.0 x 8.8 mm	4.6 x 6.1 mm	6.0 x 8.8 mm	4.6 x 6.1 mm	6.0 x 8.8 mm
Magnification	3	2.1	3	2.1	3	2.1	3	2.1
Crystal Type	C	C	P	P	R	R	G	G
Wavelength Range	110 - 225 nm	110 - 225 nm	110 - 350 nm	110 - 350 nm	110 - 535 nm	110 - 535 nm	X-ray - 400 nm	X-ray - 400 nm
Relative Response	193 nm 248 nm 308 nm	22 0.17 0.03	48 15 1	48 15 1	100 8 0.18	100 8 0.18	480 480 112	480 480 112
Saturation Level	193 nm 248 nm 308 nm	400 mJ/cm <sup>2</sup> N/A N/A	400 mJ/cm <sup>2</sup> N/A N/A	30 mJ/cm <sup>2</sup> 30 mJ/cm <sup>2</sup> 50 mJ/cm <sup>2</sup>	30 mJ/cm <sup>2</sup> 30 mJ/cm <sup>2</sup> 50 mJ/cm <sup>2</sup>	50 mJ/cm <sup>2</sup> 400 mJ/cm <sup>2</sup> 400 mJ/cm <sup>2</sup>	50 mJ/cm <sup>2</sup> 400 mJ/cm <sup>2</sup> 400 mJ/cm <sup>2</sup>	10 mJ/cm <sup>2</sup> 10 mJ/cm <sup>2</sup> 50 mJ/cm <sup>2</sup>
Decay Time		3 - 5 µs	3 - 5 µs	5 µs	5 µs	3000 µs	3000 µs	0.5 µs
Max Repetition Rate		30 - 20 kHz	30 - 20 kHz	20 kHz	20 kHz	30 Hz	30 Hz	200 kHz
Product Number		202324	202325	202328	202329	202330	202331	202326

A complete procedure on how to choose the appropriate UV Converter (UV Converter Application Note) is available on our website at [www.gentec-eo.com](http://www.gentec-eo.com).

# WAVELENGTH MANAGEMENT

## IR ADAPTOR

Typically, a CMOS silicon sensor is operating at its full potential when imaging lasers with wavelengths between 350 nm and 1150 nm\*. If you want to extend the performance range of your Beamage beam profiling camera to the near-IR telecom wavelengths band, you can use the IR Adaptor. This ideal solution takes advantage of a multi-photon absorption process to extend the sensitivity range of the camera sensor to a portion of the near-IR spectrum (1495 nm – 1595 nm).

### MAIN CHARACTERISTICS

- Converts wavelengths between 1495 nm and 1595 nm to shorter wavelengths between 950 nm and 1075 nm.
- Images larger beams due to the convergent properties of the optics (3.29X).
- Built with a high quality coated anti-reflection input window that allows wavelength conversion with low distortion and maximum image resolution.
- Removable and easily C-mounted onto the entrance port of the camera.
- Ready to use within minutes.



### SPECIFICATIONS

MODEL	IR ADAPTOR
Active Area	27.5 mm Ø
IR Spectral Range	1495 nm – 1595 nm
Peak IR Sensitivity	1510 nm and 1540 nm
Converted Wavelengths	950 nm – 1075 nm
Pixel Multiplication Factor	3.29
Minimum Beam Size	230 µm
Maximum Beam Size	19 mm
Maximum Resolution	12 lp/mm over active area 40 lp/mm at sensor focal plane
Distortion	-1.0% barrel distortion (inverted image)
Linearity	Non-Linear, IR converted output $\propto$ IR input intensity $^{1.41}$
Spectral Transmission	360 nm – 2000 nm @ F30.8
Damage Threshold	1 W/cm <sup>2</sup>
Dimensions	46 mm Ø x 97 mm L
Operating Temperature	-10°C to +40°C
Weight	210 g
Product Number	201061

### EXCITATION SPECTRUM

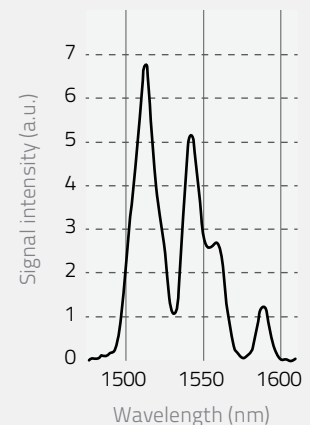

\* The Beamage-3.0 is also offered with an optional phosphor coated CMOS sensor (Beamage-3.0-IR), which is sensitive to wavelengths between 1495 nm and 1595 nm. See page 179 for more details.

# WAVELENGTH MANAGEMENT

## UV BANDPASS FILTER

We also offer a color glass filter specially designed for the UV spectrum. Depending on the wavelength, the UG11-UV filter transmits 20% to 70% of the input beam power. It is particularly useful for applications with wavelengths contained between 250 nm and 370 nm. Other wavelengths are blocked by the filter. The UG11-UV is SM1 threaded and comes with a SM1 to C-mount adaptor.

MODEL	UG11-UV
Spectral Range	280 nm – 370 nm
Diameter	25 mm Ø
Clear Aperture	80% of area
Dimensional Tolerance	+0.0/-0.2 mm
Thickness	3 mm
Thickness Tolerance	+0.0/-0.2 mm
Parallelism	< 3 arcmin
Surface Flatness	< $\lambda/4$
Maximum Power	1 W
Surface Quality	40-20 Scratch-Dig
Damage Threshold	30 W/cm <sup>2</sup> (typical)
Product Number	202602

\* Data specified at 633 nm

### SPECTRAL TRANSMISSION

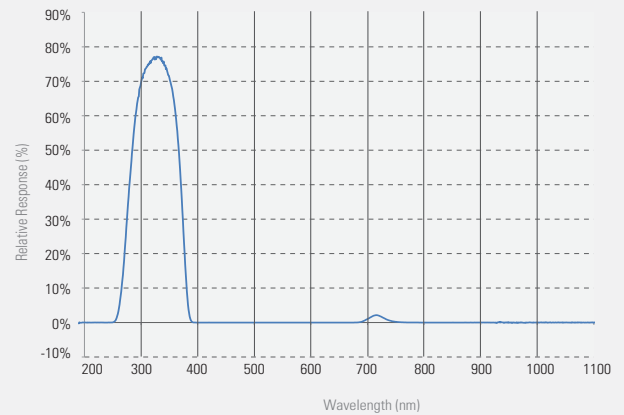

## IR FILTER

The B3-IR-FILTER is a color glass filter specifically designed for IR applications. Acting as a low-pass filter, the B3-IR-FILTER cuts all the wavelengths below 1250 nm and only lets the IR wavelengths pass. It transmits approximately 70% of the incident light. The B3-IR-FILTER is SM1 threaded and comes with a SM1 to C-mount adaptor so you can mount it on the Beamage camera.

MODEL	B3-IR-FILTER
Spectral Range	1250 – 1350 nm
Diameter	25 mm Ø
Clear Aperture	80% of area
Dimensional Tolerance	+0.0/-0.2 mm
Thickness	6.3 mm max
Parallelism	< 3 arcmin
Surface Flatness	< $\lambda/4$
Maximum Power	1 W
Surface Quality	80-50 Scratch-Dig
Damage Threshold	30 W/cm <sup>2</sup> (Typical)
Product Number	202855

### SPECTRAL TRANSMISSION

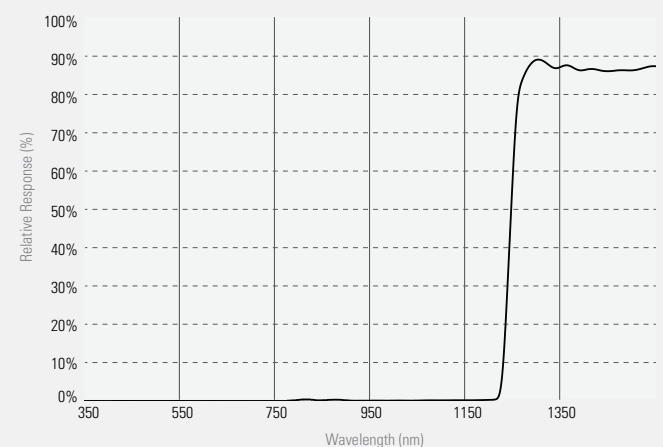

MONITORS

ENERGY DETECTORS

POWER DETECTORS

HIGH POWER SOLUTIONS

PHOTO DETECTORS

THZ DETECTORS

OEM DETECTORS

SPECIAL PRODUCTS

BEAM DIAGNOSTICS

# BEAM SIZE MANAGEMENT

## CAMERA LENSES

Camera lenses work by indirectly imaging on the sensor the reflection or the transmission of a beam that previously went through a diffusing material such as glass (see diagrams below).

It is necessary to use a Camera Lens to image beams that are larger than the CMOS sensor (11.3 mm X 6.0 mm) of the Beamage beam profiling camera.

A Camera Lens can be directly C-mounted onto the aperture of the Beamage camera.

## SPECIFICATIONS

MODEL	CL-25	CL-50
Focal Length	25 mm	50 mm
Maximum Beam Size	2000 mm X 2000 mm (not a limiting factor)	2000 mm X 2000 mm (not a limiting factor)
Maximum Measurable Intensity / Energy	Very high because of indirect mechanism	Very high because of indirect mechanism
Inverted Image	Yes	Yes
Beam Distortion	Setup, lens aberration and speckles from diffusing glass	Setup, lens aberration and speckles from diffusing glass
Diffusing Material Needed	Yes	Yes
Magnification Calibration Needed	Yes	Yes
Possibility of Wavelength Conversion	Yes	Yes
Optical Filter Needed	Rarely to never	Rarely to never
Removable	Yes	Yes
Product Number	202343	202344



To determine which lens better fits your requirements, refer to the table below.

PRODUCT	PRODUCT NUMBER	FOCAL LENGTH	HORIZONTAL FOV	FOV AT 1 m	MINIMUM WORKING DISTANCE
CL-25	202343	25 mm	14°	245 mm	0.5 m
CL-50	202344	50 mm	7°	120 mm	1 m

To calculate linear FOV (Field of View) at distances other than 1 m, simply multiply the value found in the table by the distance in meters.

## IMAGING A TRANSMITTED BEAM

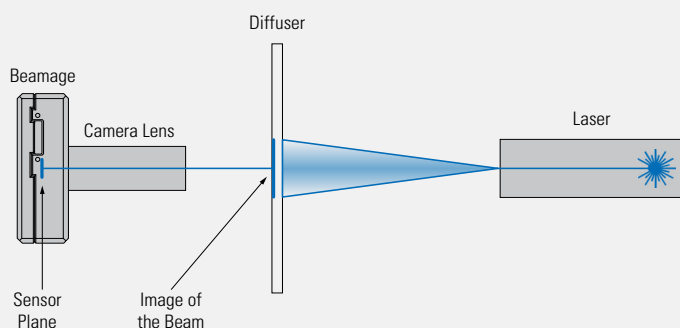

## IMAGING A REFLECTED BEAM

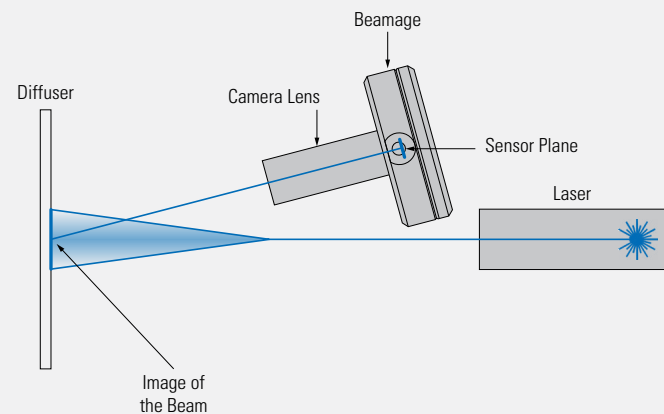

# POWER MANAGEMENT

## NEUTRAL DENSITY (ND) FILTERS - UP TO 1 W

We offer various SM1 threaded absorptive ND (Neutral Density) filters that can be fixed directly on the aperture of the Beamage camera via a SM1 to C-mount adaptor. Subsequent filters can be stacked directly on each other. These filters reduce the intensity of all wavelengths without affecting the wavefront of the beam or distorting the image. Sets of 3 filters or 6 filters as well as individual filters are available. An empty SM1 threaded filter holder is also available for those who would like to use their own ND filters with their camera. It holds 25 mm wide filters.

Each filter and each holder comes with a SM1 to C-mount adaptor.

### MAIN SPECIFICATIONS

MODEL	ND0.5 TO ND5.0
Spectral Range	400 nm – 1150 nm
Filter Diameter	25 mm Ø
Clear Aperture	22.5 mm Ø (90% of diameter)
Dimensional Tolerance	+0.0/-0.25 mm
Optical Density Tolerance	±5%
Parallelism	< 10 arcsec
Transmitted Wavefront Error	< $\lambda/10$ at 633 nm
Surface Flatness	< $\lambda/4$
Surface Quality	40-20 Scratch-Dig
Maximum Power	1 W
Damage Thresholds	100 W/cm <sup>2</sup> or 3 J/cm <sup>2</sup>

\* Data specified at 633 nm

### SPECTRAL TRANSMISSION OF ALL FILTERS

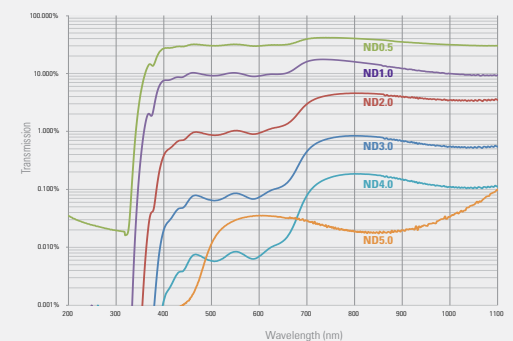

### OVERVIEW OF THE MODELS

MODEL	P/N	EQUIVALENT ATTENUATION	TRANSMITTANCE @ 633 nm	SUBSTRATE	MODEL	P/N	EQUIVALENT ATTENUATION	TRANSMITTANCE @ 633 nm	SUBSTRATE
ND0.5	201094	(1/3,16)	~32%	NG4	NDSET-6 (Set of all 6 filters)	202605	See left	See above	See left
ND1.0	201045	(1/10)	~10%	NG4	NDSET-3 (Set of 3 filters (ND1, ND2, ND3))	202606	See left	See above	See left
ND2.0	201046	(1/100)	~1%	NG9	ND-H (ND filter holder)	Call	---	---	---
ND3.0	201047	(1/1000)	~0.1%	NG9					
ND4.0	202600	(1/10 000)	~0.01%	NG9					
ND5.0	202601	(1/100 000)	~0.001%	NG9					

## VARIABLE ATTENUATOR - UP TO 1 W

The BDA-A-VAR is an easy to use variable attenuator equipped with 4 wheels, each one containing 3 filters and 1 empty space at fixed positions. The filters have transmission factors ranging from 100% to 0.003%. With 256 possible configurations, this variable attenuator offers almost continuous attenuation from 0 db to 93 dB. The BDA-A-VAR has M6 holes on 3 sides for mounting versatility and has C-mount threads on both ends for connection with the Beamage via a male to male C-Mount connecting tube (sold separately).

### SPECIFICATIONS

MODEL	BDA-A-VAR
Maximum Attenuation	93 dB (0.00000005%)
Minimum Attenuation	0 dB (0%)
Maximum Power Density	1 W/cm <sup>2</sup>
Maximum Energy Density	100 mJ/cm <sup>2</sup>
Wavelength Range	350 nm – 2200 nm
Clear Aperture	18 mm Ø
Angle Between Filters	4° (Suppresses unwanted interference fringes)
Mounting Capabilities	M6 holes on 3 sides, C-mount threads on both ends
Product Number	201116



# POWER MANAGEMENT

## BEAM SAMPLER - UP TO 40 W

The BDA-S-1000-40W-VIS/IR beam sampler uses Fresnel reflection on two orthogonal wedges to pick off a small fraction of the input beam. Within the 400 nm – 2500 nm range, it provides a fixed  $10^3$  (30 dB) attenuation that weakly depends on the wavelength. The incoming beam polarization state and irradiance are preserved. The wavefront distortion is negligible and the laser output power stability is not affected. This beam sampler has four ports: “Input”, “Sampled Beam”, “Residual Beam” and “Port 4”. It can be connected to the Beamage via a male to male C-mount adaptor (sold with the Beam Sampler) and can be easily combined with the BDA-A-VAR variable attenuator via a male to male C-mount connecting tube (sold separately).

## SPECIFICATIONS

MODEL	BDA-S-1000-40W-VIS/IR
Spectral Range	400 nm – 2500 nm
Average Attenuation	$10^3$ (30 dB)
Maximum Power Range	40 W
Aperture Diameter	17.5 mm
Max Beam Diameter	15 mm
Optical Wedges Material	UV Fused Silica
Refractive Index ( $\lambda = 532$ nm)	1.4607
Refractive Index ( $\lambda = 1064$ nm)	1.4496
Sampled Beam Lateral Shift	15 mm
Sampled Beam Deviation	$90^\circ$
Residual Beam Deviation	$5^\circ$
Product Number	202345



## BEAM SPLITTER CUBE - UP TO 40 W

- The BDA-S-10-UV/IR beam splitter cube provides attenuation and beam sampling for high power laser diagnostics. It uses the front surface of an uncoated mirror and reflects 3% to 10% of the input laser beam.
- There is no back reflection, no unwanted interference fringes, and the image of the beam is virtually undistorted.
- It can take power densities up to 2 GW/cm<sup>2</sup>.
- It is C-mount threaded. It can be connected directly to the Beamage or the BDA-A-VAR variable attenuator with compatible connecting tubes and can be mounted onto a post via its M6 holes.

## SPECIFICATIONS

MODEL	BDA-S-10-UV/IR
Reflection	3% to 10% (polarization dependent)
Spectral Range	190 nm – 2200 nm
Clear Aperture	19 mm
Damage Threshold (Power)	2 GW/cm <sup>2</sup>
Damage Threshold (Energy)	50 J/cm <sup>2</sup>
Wedge	30 arcmin
Surface Flatness	$\lambda/10$
Surface Quality	10-5 Scratch-Dig
Product Number	202604



# ACCESSORIES

## POWER SUPPLIES & BATTERIES



MODEL	DESCRIPTION	PART NUMBER
FAN-12V-US	Power Supply, 12V (US), for fan-Cooled detectors	200130B
FAN-12V-EU	Power Supply, 12V (Europe), for fan-Cooled detectors	200130C
FAN-12V-UK	Power Supply, 12V (UK), for fan-Cooled detectors	200130G
MON-9V-US	Power Supply, 9V (US). For monitors and modules.	200960B
MON-9V-EU	Power Supply, 9V (Europe). For monitors and modules.	200960C
MON-9V-UK	Power Supply, 9V (UK). For monitors and modules.	200960G
MON-BAT	Battery Pack for: MAESTRO, SOLO 2.	201013
PE-BAT	Battery Pack for: SOLO PE.	200083
UPG-12V-US	Power Supply, 12V-6.66A, for UP55G (US)	201103B
UPG-12V-EU	Power Supply, 12V-6.66A, for UP55G (Europe)	201103C
UPG-12V-UK	Power Supply, 12V-6.66A, for UP55G (UK)	201103G

## ADAPTORS & CABLES



MODEL	DESCRIPTION	PART NUMBER
DB-15-ADAPTOR	DB-15 to DB-15 Replacement Adaptor	Call
DB15-BNC	DB15 to BNC Adaptor for XLE4, QE12, QE25, QE50, QE65, QE95.	200036
EXT-4	Extension Cable (4 m)	Call
EXT-15	Extension Cable (15 m)	Call
EXT-20	Extension Cable (20 m)	Call
EXT-25	Extension Cable (25 m)	Call
PLK-RS232	RS-232 Cable for P-LINK (RS-232)	202375
MON-RS232	RS-232 Cable for : SOLO 2 and SOLO X (RS-232)	200925
MON-USB	USB Cable for : P-LINK, S-LINK, M-LINK, Mach 5, T-Rad and QUAD-4Track	202373
MAE-USB	USB Cable for : MAESTRO (also used for Beamage, SOLO PE, SOLO X)	202372
MAE-RS232	RS-232 Cable for MAESTRO	201860

## FIBER OPTIC ACCESSORIES



MODEL	DESCRIPTION	PART NUMBER
FOA-19	Fiber Optic Adaptor (19 mm threaded) for UP19K-H Series.	200180
FOA-25	Fiber Optic Adaptor (25 mm threaded) for UP25 Series.	200261
FOA-50	Fiber Optic Adaptor (50 mm threaded) for UP50-55 Series.	200183
FOA-COVER12	Fiber Optic Adaptor Cover for UP12E. 12 mm fiber adaptor cover for UP12E series.	202365
FOA-COVER50	Fiber Optic Adaptor Cover for UP55. Reduces aperture from 55 to 50 mm.	202366
FOA-CYL50	Fiber Optic Adaptor: 50 mm Conical Cylinder for UP50 series.	200052
FOA-FULL-FC	Fiber Optic Adaptor FC with full cover. For: XLP12, -B heads (except THZ) PH and STEP.	202367
FOA-FULL-SMA	Fiber Optic Adaptor SMA with full cover. For: XLP12, -B heads (except THZ) PH and STEP.	202368
FOA-FULL-ST	Fiber Optic Adaptor ST with full cover. For: XLP12, -B heads (except THZ) PH and STEP.	202369
FOC-FC	Fiber Optic Connector FC. For UP Series.	200867
FOC-SC	Fiber Optic Connector SC. For UP Series.	200182
FOC-SMA	Fiber Optic Connector SMA. For UP Series.	200868
FOC-PLUG	Fiber Optic Connector, PLUG to close port of fiber cylinder. For UP50-55 Series.	202370

# ACCESSORIES

## POUCHES AND CASES



MODEL	DESCRIPTION	PART NUMBER
MON-POUCH	Padded protection pouch with velcro flap. For MAESTRO, TUNER, UNO, P-LINK, M-LINK, and S-LINK	200128
MON-WALL	Wall Support for : SOLO 2, TUNER, UNO.	201241
PEL-1450	Pelican Carrying Case (Model 1450). 15 x 11 x 6 in.	Call
PEL-1500	Pelican Carrying Case (Model 1500). 17 x 12 x 7 in.	Call
PEL-1550	Pelican Carrying Case (Model 1550). 19 x 15 x 8 in.	Call

## STANDS & HOLDERS



MODEL	DESCRIPTION	PART NUMBER
HBS-MOUNT	1in Mount for HBS.	202371
STAND-D-233	Stand with 2 x 3in Base, 3in Cylinder, Delrin Post, 1/4-20 & 8-32 for : QE-B, QE12, QE25, QE50, QE65-S, QE95-S, Mach 5, UM-B, STEP, PH-B, PH, PE-B, TRAP, THZ-I-BNC, THZ-B, Beamage, QUAD.	200428
STAND-D-443	Stand with 4 x 4in Base, 3in Cylinder, Delrin Post, 1/4-20 & 8-32 for : QE65-H, QE95-H	201284
STAND-S-233	Stand, 2 x 3in Base, 3in Cylinder, Steel Post, 8-32 & 1/4-20 for : XLP12, UP12, UP17, UP19, THZ-D, HBS Mount.	200160
STAND-S-443	Stand, 4 x 4in Base, 3in Cylinder, Steel Post, 8-32 & 1/4-20 for : UP25, UP50, UP55, UP60.	200234
STAND-S-443-C	Stand, 4 x 4in Base, 3in Cylinder, 3in Steel Post, 8-32 & 1/4-20, with slip-on post collar for : UP55G, UP60G, FLASH, FLASH-IPL, HP and Beamage-M <sup>2</sup> .	201102

## WINDOWS & FILTERS



MODEL	DESCRIPTION	PART NUMBER
IR-FILTER	IR-FILTER for XLP12.	
M5-UC-QED	Special Attenuator for M5 ultrafast pyroelectric probes. Allows relative measurements in UV.	Call
QED-12	QE12 Attenuator.	201200
QED-25	QE25 Attenuator.	201199
QED-50	QE50 Attenuator.	201198
QED-65	QE65 Attenuator.	201282
QED-95	QE95 Attenuator.	201323
THZ-WC-13	Winston Cone Accessory for THZ-B Series Terahertz Detectors.	
OD1	OD1 attenuator for PH Series	201082
OD2	OD2 attenuator for PH Series	202374
Various Windows	Interchangeable or Permanent Windows (Barium, Quartz, Germanium, Sapphire, Silicon, Zinc)	Call

## MISCELLANEOUS



MODEL	DESCRIPTION	PART NUMBER
APM	Analog Power Module, to interface -B heads with oscilloscopes or lock-in amplifiers.	201848
BL	Organic Black (BL) Coating for QS pyroelectric detectors (not for QS-THZ).	Call
DIGS-1	Integrating Sphere, 1 in Ø, SM1 Thread. For PE-B heads.	
EXT-PCB	External PCB for UD Disks.	
QS-I-TEST	Evaluation Test Box for QS Detectors (in current mode).	201693
QS-V-TEST	Evaluation Test Box for QS detectors (in voltage mode).	201694
SDC-500	SDC-500 Digital Optical Chopper.	202171
SM1A7	Alignment Crosshair. For -I and -B heads (except THZ) and STEP.	
SM1A8	IR Alignment Aide. For -I and -B heads (except THZ) and STEP.	
UP19K-COVER	Threaded cover for UP19 Series detectors	202377
UP19K-TUBE	Isolation Tube for UP19K	202376

## DISTRIBUTORS

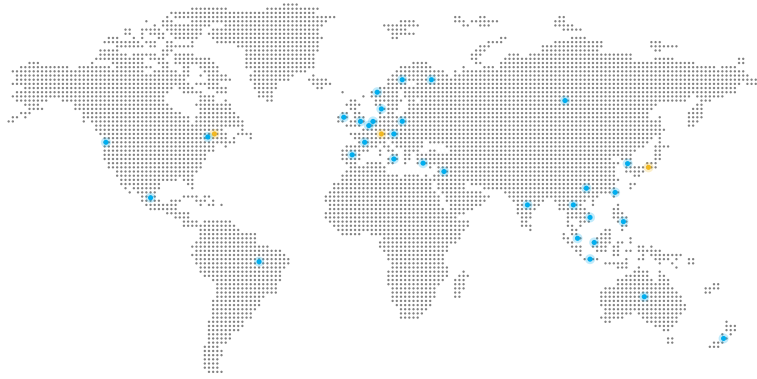

NORTH AMERICA  
EUROPE  
ASIA  
AUSTRALIA

## AUSTRALIA &amp; NEW ZEALAND

WEB  
PAGE

Lastek Pty Ltd	Mr. Alex Stanco	T +61 8 8443 8668	alex.stanco@lastek.com.au	
----------------	-----------------	-------------------	---------------------------	--

## CANADA ● ●

Gentec Electro-Optics, Inc	Mrs. Charlotte Fontaine	T 418-651-8003 ext. 310	cfontaine@gentec-eo.com	
----------------------------	-------------------------	-------------------------	-------------------------	--

## CHINA

Zugo Photonics (Beijing Branch)	Mr. Tom Gong	T +86 01 082 896 052	tom.gong@zugophotonics.com	
Zugo Photonics (Shenzhen Branch)	Mr. Leo Cai	T +86 02 162 562 268	leo.cai@zugophotonics.com	
Zugo Photonics (Shanghai Branch)	Mr. Leo Cai	T +86 02 162 562 268	leo.cai@zugophotonics.com	

## FRANCE

Laser Components France	Mrs. Elvynne Egrot	T +33 (0) 1 39 59 52 25	e.egrot@lasercomponents.fr	
-------------------------	--------------------	-------------------------	----------------------------	--

## GERMANY &amp; AUSTRIA ●

Laser Components GmbH	Mrs. Nadine Kujath	T +49 8142 2864 701	n.kujath@lasercomponents.com	
-----------------------	--------------------	---------------------	------------------------------	--

## GREECE &amp; CYPRUS

Optronics Technologies S.A.	Mrs. Nina Christodoulia	T +30 210 9837121	nchristodoulia@optronics.gr	
-----------------------------	-------------------------	-------------------	-----------------------------	--

## INDIA

Dynotech Instruments	Mr. Sudhir Sharma	T +91 11 2561 2270	sales@dynotech.in	
----------------------	-------------------	--------------------	-------------------	--

## ISRAEL

Lahat Technologies Ltd.	Mrs. Yamit Gurman	T +972 9 764 6212	yamit.gurman@lahat.co.il	
-------------------------	-------------------	-------------------	--------------------------	--

## ITALY

Acal BFi Italy Srl	Mr. Alessandro Zito	T +39 02 535 83206	alessandro.zito@acalbfi.it	
--------------------	---------------------	--------------------	----------------------------	--

## JAPAN ●

Indeco Inc.	Mr. Daisuke Sato	T +81 3 3818 4011	sato@indec.jp	
Kantum Electronics Co., LTD	Mr. Hitoshi Tsukada	T +81 45 345 0002	tsukada@kantum.co.jp	
Phototechnica Corporation	Mr. Nobuhiko Takamatsu	T +81 4 8871 0067	voc@phototechnica.co.jp	

## KOREA

QBIC Laser System	Mr. Chang Kon Kim	T +82 32 325 4544	ckkim@qbiclaser.com	
-------------------	-------------------	-------------------	---------------------	--

## MALAYSIA

Zugo Photonics Sdn Bhd	Mr. Eddy Looi	T +60 380 236 969	eddy.looi@zugophotonics.com	
------------------------	---------------	-------------------	-----------------------------	--

## DISTRIBUTORS



## NETHERLANDS, BELGIUM &amp; LUXEMBOURG

WEB  
PAGE

Acal Bfi Netherlands B.V.	Mr. Rob Satink	T +31 (0)40 250 7400	rob.satink@acalbfi.nl	
---------------------------	----------------	----------------------	-----------------------	--

## POLAND

Lasotronix	Mr. Darek Demarczyk	T +48 500 100 131	dd@lasotronix.pl	
------------	---------------------	-------------------	------------------	--

## RUSSIAN FEDERATION

Eurolase	Mr. Aleksandr Khudobenko	T +7 (499) 124 28 89	eurolase@eurolase.ru	
----------	--------------------------	----------------------	----------------------	--

## SCANDINAVIA

Laser Components Nordic AB	Mr. Mikael Winters	T +46 (0)31 703 71 73	m.winters@lasercomponents.se	
----------------------------	--------------------	-----------------------	------------------------------	--

## SINGAPORE

Zugo Photonics Pte Ltd	Mr. Kelvin Choong	T +65 68 440 055	kelvin.choong@zugophotonics.com	
------------------------	-------------------	------------------	---------------------------------	--

## SOUTH AND CENTRAL AMERICA &amp; MEXICO

Laser-Blvd	Mr. Eduardo Parker	T 408-503-6458	latinamerica@gentec-eo.com	
------------	--------------------	----------------	----------------------------	--

## SPAIN AND PORTUGAL

Alava Ingenieros	Mr. Antonio Castelo	T +34 91 567 97 63	acastelo@alava-ing.es	
------------------	---------------------	--------------------	-----------------------	--

## SWITZERLAND

GMP SA	Mr. Babak Bayani	T +41 79 905 89 90	babak.bayani@gmp.ch	
--------	------------------	--------------------	---------------------	--

GMP SA - Büro Zürich	Mr. Stefano Okretic	T +41 44 825 34 00	stefano.okretic@gmp.ch	
----------------------	---------------------	--------------------	------------------------	--

## TAIWAN

ONSET Electro-Optics Co. Ltd.	Mr. Frank Hsu	T +886 2 8919 1688	frank@onset-eo.com	
-------------------------------	---------------	--------------------	--------------------	--

## THAILAND

Zugo Photonics Co Ltd	Mr. Wanchai Eakoraphan	T +66 26 402 955	wanchai@zugophotonics.com	
-----------------------	------------------------	------------------	---------------------------	--

## UK &amp; IRELAND

Laser Lines Ltd.	Mrs. Kim Akram	T +44 1 295 672 500	kima@laserlines.co.uk	
------------------	----------------	---------------------	-----------------------	--

## UNITED STATES - EAST COAST

Gentec Electro-Optics, Inc.	Mrs. Charlotte Fontaine	T 418-651-8003 ext. 310	cfontaine@gentec-eo.com	
-----------------------------	-------------------------	-------------------------	-------------------------	--

## UNITED STATES - WEST COAST

Gentec-EO USA, Inc.	Mr. Burt Mooney	T 503-697-1870	bmooney@gentec-eo.com	
---------------------	-----------------	----------------	-----------------------	--

Countries with a calibration center

Countries with a Gentec-EO office



## CALIBRATION AND REPAIR SERVICE

All Gentec-EO products receive an NIST traceable calibration and are shipped with a Calibration Certificate to prove it. The certificate tells you the sensitivity of your power or energy head, the ambient calibration conditions, and a list of all the NIST traceable standards and instruments used in the calibration.

The actual need for recalibration depends on use and environmental conditions. Under typical operating conditions and laser exposures annual recalibration is the industry standard recommended by calibration experts such as NIST. Our highly professional service department is happy to recalibrate or repair your instrument any time you need it. In every case, you will get the same accurate calibration and detailed certificate as when your instrument was new. In addition, we do an incoming calibration test to let you know how the device was performing before service. We will help you meet any ISO and quality requirements. Here is how to send an RMA request:



### BY PHONE

Mr. Nicolas Litalien  
1-418-651-8003 ext. 302



### BY E-MAIL

Mr. Nicolas Litalien  
[service@gentec-eo.com](mailto:service@gentec-eo.com)



### USING OUR ONLINE RMA FORM

Go to <http://gentec-eo.com/support>  
Fill out the online form and click "SUBMIT MY REQUEST"

IN ALL CASES, PLEASE PREPARE THE FOLLOWING INFORMATION BEFORE CONTACTING US:

- Model Name(s)
- Serial Number(s)
- If a repair is needed, please provide a description of the problem

## WARRANTY

Annual recalibration is an industry standard that is recommended to ensure the most accurate measurements all the time. Now you can turn that into a Lifetime Warranty for Gentec-EO joulemeters or wattmeters. As long as the purchaser has returned the product once a year, every year, since purchase, they will get routine repairs for no additional charge. Your cost is just the modest calibration fee for your product. The only condition is that it must not have been subject to unauthorized service or damaged by misuse, including laser exposure outside of our published specifications. You always have parts, labor and recalibration service for no charge if service is necessary the first year after purchasing any of our products. Why stop there when you can protect your investment for the life of the product? Take advantage of our Lifetime Warranty.



WWW.GENTEC-EO.COM

# LEADER IN LASER BEAM MEASUREMENT **SINCE 1972**

## CANADA

445 St-Jean-Baptiste, Suite 160  
Quebec, QC, G2E 5N7, Canada

**T** (418) 651-8003

**F** (418) 651-1174

1 (888) 5GENTEC (Canada and USA only)

info@gentec-eo.com

## UNITED STATES

5825 Jean Road Center  
Lake Oswego, OR, 97035, USA

**T** (503) 697-1870

**F** (503) 697-0633

1 (888) 5GENTEC (Canada and USA only)

info@gentec-eo.com

## CALIBRATION CENTERS

- 445 St-Jean-Baptiste, Suite 160  
Quebec, QC, G2E 5N7, Canada
- Werner von Siemens Str. 15  
82140 Olching, Germany
- 1-11-14, Kasuga, Bunkyo-ku,  
Tokyo 112-0003, Japan