

CXTILT

HIGH ACCURACY, DIGITAL SERIES

- ▼ Digital Roll and Pitch Output
- ▼ RS-232 Interface
- ▼ Programmable Resolution and Settling Time

Applications

- ▼ Platform Leveling
- ▼ Precision Tilt Measurements
- ▼ Geo-mechanical Leveling
- ▼ Lab Instrumentation



CXTILT02E

The CXTILT02E inclinometer offers outstanding resolution, dynamic response and accuracy. The CXTILT02E measures the tilt angle of an object with respect to the horizontal in a static environment. To measure tilt, also called roll and pitch, the sensor makes use of two micro-machined accelerometers, one oriented along the X-axis and one along the Y-axis.

The CXTILT02E is a "smart" sensor with an embedded micro-controller, and A/D converter. The combination of sensing elements and digital electronics yields a system requiring no user calibration. The sensor's resolution and settling time are programmable, allowing the CXTILT02E to be customized for various applications.

CXTILT02EC

The CXTILT02EC provides superior performance in more demanding measurement applications, where high accuracy must be maintained over a wide temperature range of -40 to +85°C. The CXTILT02EC employs Crossbow's Softsensor® calibration and an on board temperature sensor to internally compensate for temperature-induced drift.

LINEARIZED

The CXTILT02EC is also characterized by very high linearity and designed specifically for use in construction environments. This extremely high linearity is achieved through Crossbow's proprietary Softsensor® linearization calibration.

tilt sensors

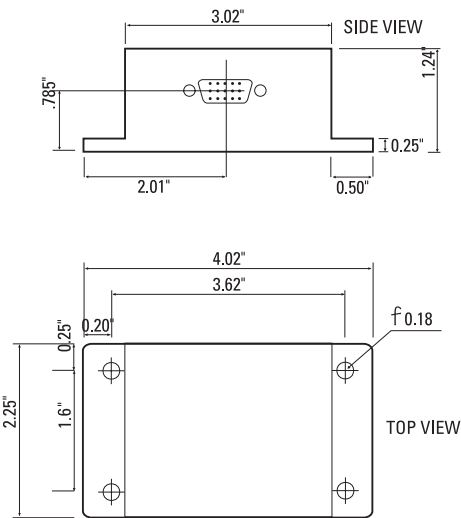

Aluminum Package

Specifications	CXTILT02E	CXTILT02EC	Remarks
Performance			
Accuracy (°)	± 0.4	± 0.2	at ± 20° (at 25°C)
Angular Range (°)	± 75	± 75	From horizontal
Angular Drift w/Temp (°)	1.5	0.7	Up to ± 20° Tilt
Angular Resolution (°)	See Table 1	See Table 1	
Settling Time (s)	See Table 1	See Table 1	
Null Angular Offset (°)	< 0.5	< 0.5	Actual value provided w/sensor
Non-Linearity (± 45°) (%)	< 11	< 0.3	Measured at 25° C
Transverse Sensitivity (%)	1	1	Typical
Environment			
Temperature Range (°C)	0 to +70	-40 to +85	
Electrical			
RS-232 Interface (Baud)	9600	9600	
Supply Voltage (Volts DC)	8-30	8-30	
Supply Current (mA)	60	60	
Physical			
Size	4.02 x 2.26 x 1.24" (10.21 x 5.74 x 3.15 cm)		
Weight	5.9 oz (166 gm) 5.9 oz (166 gm)		

Specifications subject to change without notice

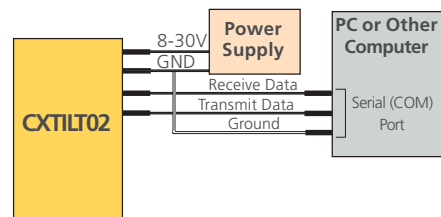

Typical CXTILT02 Configuration

Pin	Function
4	Transmit Data
3	Receive Data
1	GND
11	Input Power

Pin Diagram

Filter	Fc(Hz)	Tc(s)	Typical Resolution (°)
0	none	none	0.320
1	12.5	0.025	0.101
2	9.9	0.029	0.091
3	5.0	0.042	0.064
4	2.5	0.074	0.045
5*	1.2	0.14	0.032
6	0.64	0.26	0.023
7	0.33	0.52	0.016
8	0.17	1.03	0.012
9	0.09	2.05	0.009

Note
Filter 0 implies no digital IIR filter, but there is a 50 Hz ± 30 Hz single pole response from the MEMS sensor
*Default setting

Table 1. CXTILT02 Programmable Filter Settings

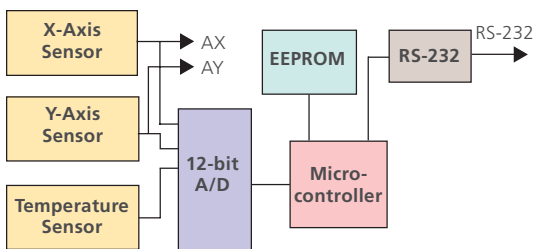

Block Diagram of CXTILT02



tilt sensors

Ordering Information

Model	Description	Angular Range	Temperature Range
CXTILT02E	Enhanced	± 75°	0 to +70°C
CXTILT02EC	Enhanced & Compensated	± 75°	-40 to +85°C

CALL FACTORY FOR OTHER CONFIGURATIONS

Application Information

CXTILT02 CONFIGURATION & CALIBRATION



Command	Function Description/Response
R	Reset. Resets the CXTILT firmware to default settings. An ASCII 'H' (72) is sent in response.
G	Get Angle Data Packet. The CXTILT returns its current angular position. The data is in a 6 byte packet defined in Table 3.
N<0-9>	Set Resolution Level. A 2 byte command sequence that configures the CXTILT's internal digital filter. The second byte, an integer of value 0-9, sets the level of filtering.
C	Continuous Mode: Transfers packet continuously at maximum rate.
S	Stop Continuous Mode.

Table 2. CXTILT02 Serial Commands

Configuration

The CXTILT02 digital inclinometers transfer data and are configured by sending commands via the serial RS-232 link. Commands consist of single and multiple byte instructions sent from the host to the CXTILT02 (see Table 2).

The CXTILT02 responds by sending single byte and multiple byte packets back to the host. When sending successive commands (e.g., polling the CXTILT02 for angular information), it is recommended that the controlling software waits for a complete response from the CXTILT02 before issuing new commands. Table 3 lists the contents of each data packet.



Angular Resolution

The angular noise limits the resolution or granularity in which small angular changes can be detected. The angular noise is dependent on the measurement bandwidth. The measurement bandwidth is the set of frequencies to which the tilt sensor responds. Decreasing the measurement bandwidth increases the resolution. At the same time, however, decreases in measurement bandwidth also increase the settling time of the sensor. If the measurement bandwidth is set too low, the tilt sensor may take an unacceptably long time to settle to its final value. The CXTILT02 is unique in its ability to provide high resolution and short settling time. The CXTILT02 is factory configured to the default resolution and settling time shown in Table 1. The CXTILT02 is also unique in its ability to be user configured for different measurement bandwidths (and hence resolution and settling time). The sensor is configured via the RS-232 interface.

Table 1 shows the resolution and settling time for various values of resolution level. Note that the CXTILT02 returns to the default resolution level (5) upon power-up and must be re-configured as required.

Contents of Data Packet		
Byte	Description	Note: Angles are represented as two's complement 16 bit numbers. +90°
0	Header (always 255)	
1	Pitch MSB (0-255)	corresponds to 32,767. -90°
2	Pitch LSB (0-255)	corresponds to -32,768. The 16-bit
3	Roll MSB (0-255)	signed angle can be obtained by this
4	Roll LSB (0-255)	simple 'C' expression: (int) Roll LSB +
5	Checksum (8-bit sum of bytes 1-4)	(int) 256 * Roll MSB

Table 3

Calibration

The CXTILT02 is factory calibrated and, in most circumstances, requires no on-site calibration by the user. The sensor's scale factor and offset are calibrated at the factory, and this information is stored in the system EEPROM. The limitations in absolute accuracy are errors in alignment induced during mounting, accuracy limitations in the factory calibration jig, and long term drifts in the electronic components. When better than 0.5° of "absolute" accuracy is required, the sensor should be leveled on-site. Also, if the part has been placed in storage for an extended time period or exposed to temperature extremes, calibration for absolute level is recommended. The onsite procedure is to simply place the CXTILT02 on a known level surface and read the angular value it is reporting. The sensor should in theory read 0.00, but the sensor might report a slight offset. Record this offset and subtract it from all of the readings reported by the CXTILT02. This procedure delivers the best absolute accuracy performance.

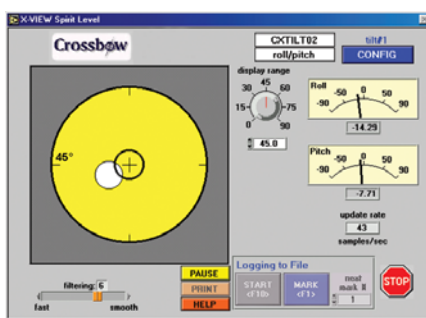

Figure 1. Development Software

Development Software

Crossbow development software ACCEL-VIEW is available with the CXTILT02 for use with PCs running Microsoft® Windows®. The software demonstrates the functionality of the CXTILT02. It is a convenient way to get started with system development, evaluate the performance of the CXTILT02 sensor, and use the CXTILT02 in straightforward leveling applications. The software is shipped on a CDROM. Figure 1 and 2 show screen shots of the display.



Customizations

Custom packages for the CXTILT02 are available for OEM customers. Please contact the factory for more information.

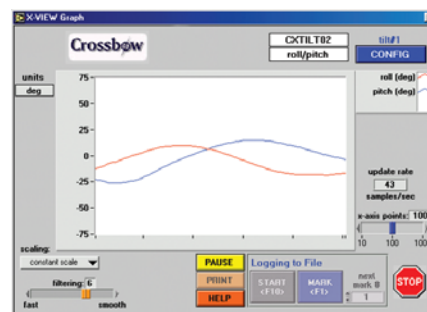

Figure 2. Development Software

tilt sensors