



Vaisala Weather Transmitter WXT520



Quality weather data you can afford

Vaisala Weather Transmitter WXT520

Access to Real Time Weather Data



Features/Benefits

- Measures 6 most essential weather parameters
- Accurate and stable
- Low power consumption - works also with solar panels
- Compact, light-weight
- Easy to install
- No moving parts
- Vaisala Configuration Tool for pc
- USB connection
- IP66 housing with mounting kit
- Applications: weather stations, dense networks, harbors, marinas

The Vaisala Weather Transmitter WXT520.

Six-in-one

With the world becoming increasingly sensitive to weather and climate, it is important to measure the weather accurately. The Vaisala Weather Transmitter WXT520 offers the solution to measure barometric pressure, humidity, precipitation, temperature, and wind speed and direction - all with one instrument!

Applications

Compact and lightweight, the WXT520 is suitable for weather stations, dense networks, buildings, golf courses, marinas, harbors, and hotels - almost anywhere where real time weather data is needed. Accurate and reliable data provided to you early enough can increase safety to life and property.

How does WXT520 do it?

To measure wind speed and direction, the WXT520 has the Vaisala WINDCAP® sensor that uses ultrasound to determine horizontal wind speed and direction. The array of three equally spaced transducers on a horizontal plane is a Vaisala specific

design, which ensures accurate wind measurement from any horizontal wind direction without blind angles and corrupted readings.

Barometric pressure, temperature, and humidity measurements are combined in the PTU module using capacitive measurement for each parameter. It is easy to change the module without any contact with the sensors.

Precipitation measurement is based on the Vaisala RAINCAP® sensor. For details, please see the next page.

Heating

The wind and rain sensors can be equipped with heating, which improves the availability of correct measurement data at all times. Heating also reduces moisture and ice forming on the surface of the transducers.

The heating circuit is independent of the operational power. The WXT520 has an automatic control circuit that switches the heating on at low

temperatures, well before the freezing point.

Powered by the sun

As the power consumption of the WXT520 is very low, it can use solar panels as an energy source. Not only does this save energy, but also allows you to use the WXT520 in remote areas where electricity is not available.



Heating at work in a WXT520.

Measuring acoustic precipitation

For business or pleasure, you can measure precipitation with the WXT520. The measurement is based on the unique Vaisala RAINCAP® Sensor, which detects the impact of individual rain drops. The signals exerting from the impacts are proportional to the volume of the drops. Hence, the signal from each drop can be converted directly to the accumulated rainfall.

Compared to traditional precipitation gauges, the Vaisala RAINCAP® Sensor gives more detailed information on precipitation. The WXT520 measures accumulated rainfall, rain intensity and duration of the rain — all in real time. This measurement method allows for the elimination of flooding, clogging, wetting, and evaporation losses in rain measurement.

The Vaisala RAINCAP® Sensor is the only maintenance-free precipitation sensor on the market.

Installation and maintenance

The WXT520 is always delivered pre-configured from the factory. To change the factory settings, you can use the Vaisala Configuration Tool based on Microsoft Windows®.

The WXT520 is easy to install with its one-bolt mounting method.

The WXT520 can be mounted either on top of a pole mast or on to a cross arm. For facilitating the installation to the pole mast and eliminating the risk of misalignment during use, an optional mounting kit is available. With the mounting kit the north alignment needs to be performed only once.

The WXT520 housing with the mounting kit is water resistant and classified as IP66.



A WXT520 in the rain chamber in Vaisala.



A WXT520 being installed at the top of the 72-meter tower at the Olympic Stadium in Helsinki, Finland.

Technical Data

Wind

Speed	
range	0 ... 60 m/s
response time	250 ms
accuracy	
0 ... 35 m/S	±0.3 m/s or ±3%, whichever is greater
35 m/s ... 60 m/s	±5%
output resolution	0.1 m/s (km/h, mph, knots)
Direction	
azimuth	0 ... 360°
response time	250 ms
accuracy	±3°
output resolution	1°

Liquid precipitation

Rainfall	
	cumulative accumulation after the latest automatic or manual reset
output resolution	0.01 mm (0.001 inches)
accuracy	5%*
Rainfall duration	
	counting each ten-second increment whenever water droplet is detected
output resolution	10 s
intensity	one-minute running average in ten-second steps
range	0 ... 200 mm/h (broader range with reduced accuracy)
output resolution	0.1 hits/h (0.01 inches/h)
Hail	
	cumulative amount of hits against the collecting surface
output resolution	0.1 hits/cm ² (0.01 hits/in ²), hits
Hail duration	
	counting each ten-second increment whenever hailstone is detected
output resolution	10 s
Hail intensity	
	one-minute running average in ten-second steps
output resolution	0.1 hits/cm ² h (0.01 hits/in ² h), hits/h

* Due to the nature of the phenomenon, deviations caused by spatial variations may exist in precipitation readings, especially in a short time scale. The accuracy specification does not include possible wind induced errors.

Air temperature

Range	-52 ... +60 °C (-60 ... +140 °F)
Accuracy for sensor at +20 °C	±0.3 °C (±0.5 °F)
Accuracy over temperature range (see graph below)	

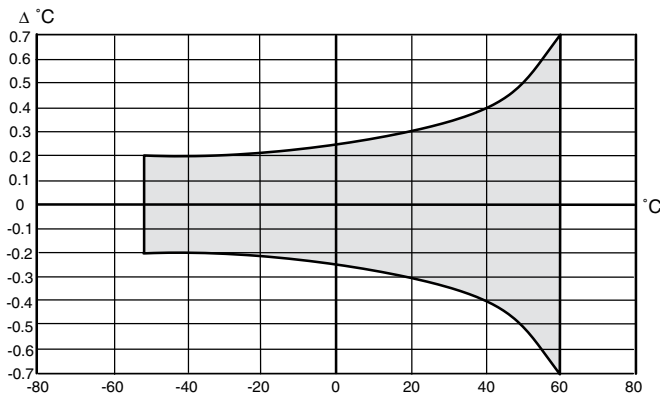

Barometric pressure

range	600 ... 1100 hPa
accuracy	±0.5 hPa at 0 ... +30 °C (+32 ... +86 °F) ±1 hPa at -52 ... +60 °C (-60 ... +140 °F)
output resolution	0.1 hPa, 10 hPa, 0.0001 bar, 0.1 mmHg, 0.01 inHg

Relative humidity

Range	0 ... 100 %RH
Accuracy	±3 %RH within 0 ... 90 %RH ±5 %RH within 90 ... 100 %RH
Output resolution	0.1 %RH

General

Operating temperature	-52 ... +60 °C (-60 ... +140 °F)
Storage temperature	-60 ... +70 °C (-76 ... +158 °F)
Input voltage	5 ... 32 VDC
Typical power consumption	3 mA at 12 VDC (with defaults)
Heating voltage	DC, AC, full wave rectified AC
Serial data interface	SDI-12, RS-232, RS-485, USB connection
Housing	IP65
Housing with mounting kit	IP66

Electromagnetic compatibility

Complies with EMC standard EN61326-1; Industrial Environment	
IEC standards	IEC 60945/61000-4-4 IEC 60945/61000-4-2

Dimensions

Dimension in mm (inches)

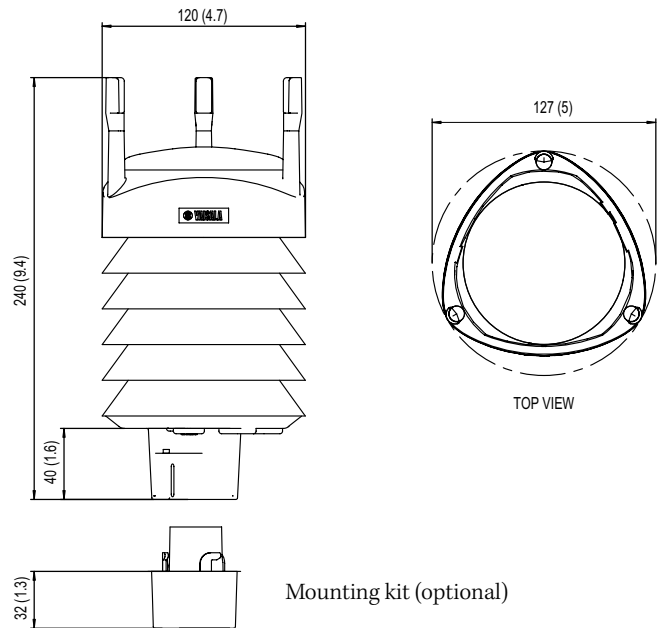

BAROCAP®, HUMICAP®, RAINCAP®, THERMOCAP® and WINDCAP® are registered trademarks of Vaisala. Specifications subject to change without prior notice. © Vaisala Oyj

