



PHOTOMETRIC AND RADIOMETRIC PROBES WITH OUTPUT SIGNAL IN mV OR NORMALIZED 4÷20mA OR 0÷10Vdc OUTPUT

Photo-radiometric probes with output signal in mV or standard output 4÷20mA or 0÷10Vdc. The probes of the series LP...03 for outdoor use allow to measure photometric and radiometric quantities such as: illuminance (lux), irradiance (W/m²) in the near ultraviolet spectral region VIS-NIR, UVA, UVB, and the photon flow across the PAR region (400nm...700nm). The probes with mV output do not require any power supply. The output signal is obtained from a resistance that short-circuits the terminal of the photodiode. The ratio of generated photocurrent to incident light power is converted into a Difference of Potential that can be read by a voltmeter. Once the DDP (Difference of Potential) is known, the measured value can be calculated through the calibration factor. All probes are individually calibrated and the calibration factor is also shown on the probe housing. The probes with normalized output current 4÷20mA or voltage 0÷10Vdc require external power supply. The probe LP UVB 03 is available only with standard output voltage 0÷5Vdc and requires external power supply. All probes of the series LP...03 are equipped with diffuser for cosine correction and protection dome.

M12 male 4-pole connector.

Cables with female connectors and with 2, 5 or 10m length available on request. On request female connector cable 2, 5 or 10 m long.

LP PHOT 03

The probe LP PHOT 03 measures illuminance (lux), defined as the ratio between the luminous flux (lumen) passing through a surface and the surface area (m²). The spectral response curve of a photometric probe is similar to the human eye curve, known as standard photopic curve V(λ). The difference in spectral response between LP PHOT 03 and the standard photopic curve V(λ) is calculated by means of the error f1. Calibration is carried out by comparison with a reference luxmeter, calibrated by a Primary Metrological Laboratory. The Calibration Procedure complies with the CEI publication No.69 "Methods of characterizing illuminance meters and luminance meters: Performance, characteristics and specifications, 1987".

The photometric measurement probe is designed for outdoor readings. CIE photopic filter. Cosine correction filter and K5 glass dome. The heating option allows you to operate at low temperatures with good results. Output, according to the chosen configuration, mV or normalized output 4÷20mA or 0÷10Vdc.

TECHNICAL SPECIFICATIONS:

Typical sensitivity:	0.5 ÷ 1.5 mV/(klux)
Spectral range:	V(λ) (see figure)
Calibration uncertainty:	< 4%
f ₁ (agreement with the standard curve V(λ)):	<6%
f ₂ (Cosine response)	<3%
f ₃ (linearity)	<1%
Measuring range:	0-200 klux
Viewing angle:	2π sr
Operating temperature:	-40°C ÷ +60°C heated version -20°C ÷ +60°C standard version
Impedance:	0.5 ÷ 1.0 KΩ non-normalized version
Version with normalized output 4÷20mA:	4mA = 0 klux, 20mA = 150 klux
Version with normalized output 0÷10Vdc	0V = 0 klux, 10V = 150klux
Power supply:	10...30Vdc for version with normalized output 4÷20mA 15...30Vdc for version with normalized output 0÷10Vdc

Typical spectral response curve of LP PHOT 03:

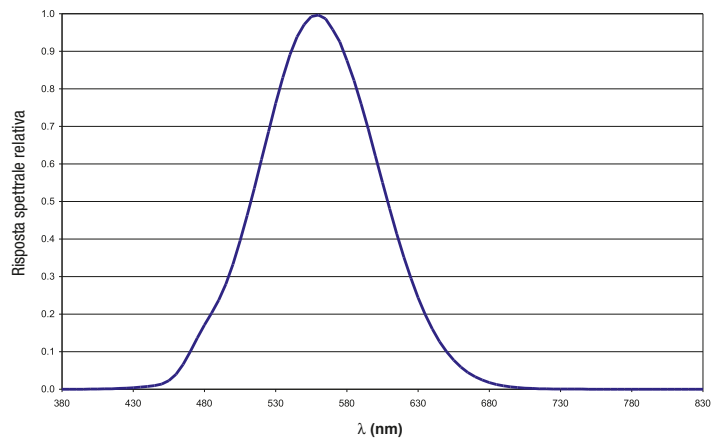

PURCHASING CODE

LP PHOT 03: Photometric probe for the measurement of illuminance, complete with K5 dome, flying female 4-pole connector, calibration report. **Cable with female connector has to be ordered separately.** Cables: CPM12 AA 4...with cable length 2, 5 or 10 meters.

LP PHOT	<input type="checkbox"/>	03 = mV per klux 03BL = mV per klux, base with levelling device 03BLAC = mV per klux, base with levelling device output 4÷20 mA 03BLAV = mV per klux, base with levelling device output 0÷10 mA
---------	--------------------------	--

CABLE:	<input type="checkbox"/>	2 = length 2m 5 = length 5m 10 = length 10m
--------	--------------------------	---

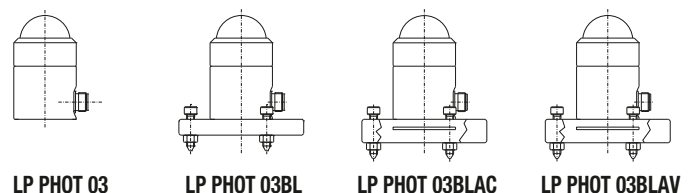

WIRING DIAGRAM
4-pole wire CPM12AA4...

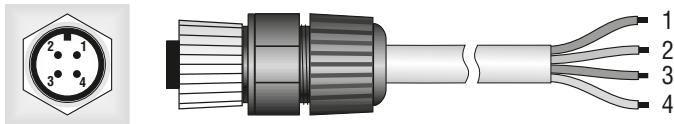

Fixed 4-pole plug M12 Flying 4-pole M12 socket

LPPHOT 03, LP PHOT 03BL

Connector	Function	Color
1	Positive (+)	Red
2	Negative (-)	Blue
3	Not connected	White
4	Shield	Black

LP PHOT 03BLAV

Connector	Function	Color
1	(+) V out	Red
2	(-) V out and (-) Vdc	Blue
3	(+) Vdc	White
4	Shield	Black

LP PHOT 03BLAC

Connector	Function	Color
1	Positive (+), (+) Vdc	Red
2	Negative (-), (-) Vdc	Blue
3	Not connected	White
4	Shield	Black

LP RAD 03

LP RAD 03 probe measures irradiance (W/m^2) defined as the ratio between the radiant flux (W) passing through a surface and the surface area (m^2) in the VIS-NIR (400nm-1050nm) spectral range. The probe is designed for **outdoor** readings. Cosine correction filter and K5 glass dome. Output, according to the chosen configuration, in μV per $\mu W/cm^2$ or $4 \div 20mA$ or $0 \div 10Vdc$ normalized output.

Technical specifications

Typical sensitivity: $1 \div 2.5 \mu V/(\mu W/cm^2)$
 Spectral range: $400nm \div 1050nm$
 Calibration uncertainty: $<5\%$
 f_2 (cosine response): $<3\%$
 f_3 (linearity): $<1\%$
 Operating temperature: $-40^\circ C \div +60^\circ C$ heated version
 $-20^\circ C \div +60^\circ C$ standard version
 Impedance: $0.5 \div 1.0 K\Omega$ non-normalized version
 Version with normalized output $4 \div 20mA$: $4mA = 0 W/m^2$, $20mA = 2000 W/m^2$
 Version with normalized output $0 \div 10Vdc$: $0V = 0 W/m^2$, $10V = 2000 W/m^2$
 Output impedance: $0.5 \div 1.0 K\Omega$ non-normalized version
 Power supply: $10 \dots 30Vdc$ for version with normalized output $4 \div 20mA$
 $15 \dots 30Vdc$ for version with normalized output $0 \div 10Vdc$

Typical spectral response curve **LP RAD 03**

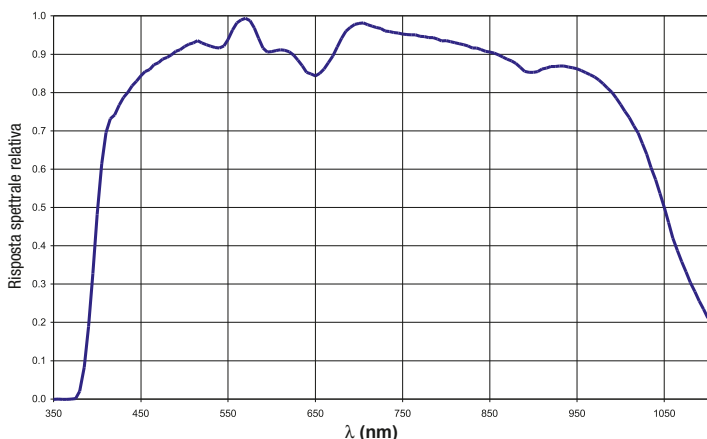

PURCHASING CODE

LP RAD 03: Radiometric probe for the measurement of irradiance, complete with K5 dome, flying 4-pole. Cable with female connector has to be ordered separately
 Cables: **CPM12 AA 4** with cable length 2, 5 or 10 meters.

LP RAD	03 = μV per $\mu W/cm^2$
	03BL = $\mu V/(\mu W/cm^2)$, base with levelling device
	03BLAC = $\mu V/(\mu W/cm^2)$, base with levelling device output $4 \div 20 mA$
	03BLAV = $\mu V/(\mu W/cm^2)$, base with levelling device output $0 \div 10 mA$

CABLE:

CPM12 AA 4	2 = length 2m
	5 = length 5m
	10 = length 10m

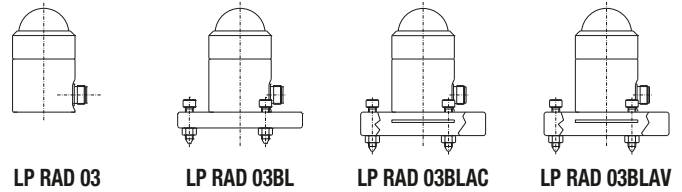

WIRING DIAGRAM
4-pole wire CPM12AA4...

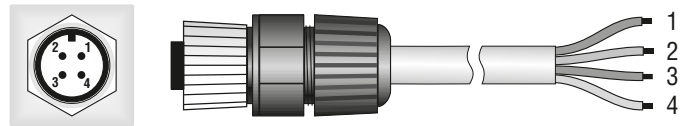

Fixed 4-pole plug M12 Flying 4-pole M12 socket

LP RAD 03, LP RAD 03BL

Connector	Function	Color
1	Positive (+)	Red
2	Negative (-)	Blue
3	Not connected	White
4	Shield	Black

LP RAD 03BLAV

Connector	Function	Color
1	(+) V out	Red
2	(-) V out and (-) Vdc	Blue
3	(+) Vdc	White
4	Shield	Black

LP RAD 03BLAC

Connector	Function	Color
1	Positive (+)	Red
2	Negative (-)	Blue
3	Not connected	White
4	Shield	Black

LP PAR 03

The probe LP PAR 03 measures the ratio between the number of photons that strike a surface in one second, in the 400nm-700nm spectral range and the surface area (m^2). This quantity is defined as PAR: Photo-synthetically Active Radiation. The probe calibration is carried out by using an halogen lamp, with a known spectral irradiance in a specific spectral range. Temperature slightly affects the probe spectral response. The probe is designed for **outdoor** readings. Cosine correction filter and K5 glass dome. Output, according to the chosen configuration, in μV per $\mu mol m^{-2}s^{-1}$ or normalized outputs $4 \div 20mA$ or $0 \div 10Vdc$.

Environmental Analysis

TECHNICAL SPECIFICATIONS

Typical sensitivity:	1 ÷ 2.5 $\mu\text{V}/(\mu\text{mol}/(\text{m}^2\text{s}^{-1}))$
Typical spectral range:	400 nm ÷ 700 nm
Calibration uncertainty:	<5%
f_2 (cosine response):	<3%
f_3 (linearity):	<1%
Operating temperature:	-40°C ÷ +60°C heated version -20°C ÷ +60°C standard version
Impedance:	0.5 ÷ 1.0 K Ω non-normalized version
Version with normalized output 4 ÷ 20mA:	4mA = 0 $\mu\text{mol}/(\text{m}^2\text{s}^{-1})$, 20mA = 5000 $\mu\text{mol}/(\text{m}^2\text{s}^{-1})$
Version with normalized output 0 ÷ 10Vdc:	0V = $\mu\text{mol}/(\text{m}^2\text{s}^{-1})$, 10V = 5000 $\mu\text{mol}/(\text{m}^2\text{s}^{-1})$
Power supply:	10...30Vdc for version with normalized output 4 ÷ 20mA 15...30Vdc for version with normalized output 0 ÷ 10Vdc

Typical spectral response curve LP PAR 03:

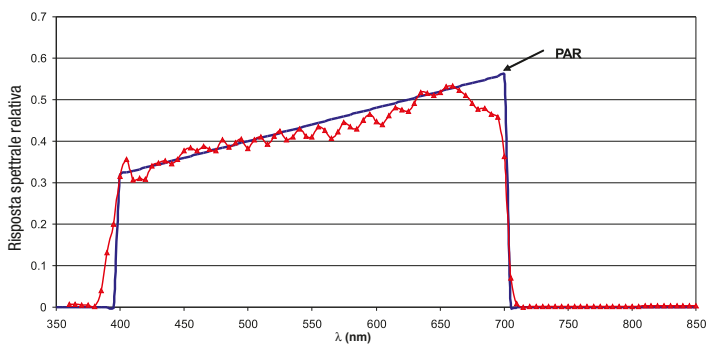

PURCHASING CODE

LP PAR 03 Radiometric probe for the measurement of the Photon flux in the PAR action spectra, complete with K5 dome, flying 4-pole connector. **Cable with female connector has to be ordered separately.** Cables: **CPM12 AA 4** ... with cable length 2, 5 or 10 meters.

LP PAR	<input type="checkbox"/>	03 = μV per $\mu\text{mol m}^{-2}\text{s}^{-1}$ 03BL = μV per $\mu\text{mol m}^{-2}\text{s}^{-1}$, base with levelling device 03BLAC = μV per $\mu\text{mol m}^{-2}\text{s}^{-1}$, base with levelling device output 4 ÷ 20 mA 03BLAV = μV per $\mu\text{mol m}^{-2}\text{s}^{-1}$, base with levelling device output 0 ÷ 10 mA
--------	--------------------------	---

CABLE:	<input type="checkbox"/>	CPM12 AA4	<input type="checkbox"/>	2 = length 2m 5 = length 5m 10 = length 10m
--------	--------------------------	------------------	--------------------------	--

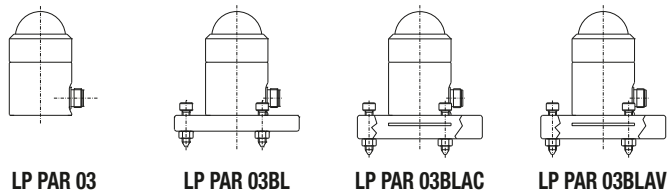

WIRING DIAGRAM 4-pole wire CPM12AA4...

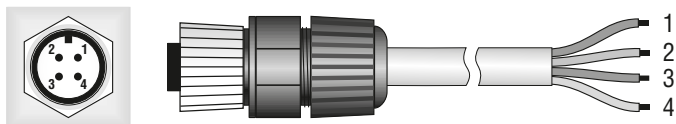

Fixed 4-pole plug M12 Flying 4-pole M12 socket

LP PAR 03, LP PAR 03BL

Connector	Function	Color
1	Positive (+)	Red
2	Negative (-)	Blue
3	Not connected	White
4	Shield	Black

LP PAR 03BLAV

Connector	Function	Color
1	(+) V out	Red
2	(-) Vout and (-) Vdc	Blue
3	(+) Vdc	White
4	Shield	Black

LP PAR 03BLAC

Connector	Function	Color
1	Positive (+)	Red
2	Negative (-)	Blue
3	Not connected	White
4	Shield	Black

LP UVA 03

The LP UVA 03 probe measures irradiance (W/m^2) defined as the ratio between the radiant flux (W) passing through a surface and the surface area (m^2) in the UVA (315 nm – 400 nm) spectral range. Thanks to a new type of photodiode, LP UVA 03 is blind to visible and infrared light.

Probe calibration is carried out by using a 365 nm line of a Xe-Hg, filtered through a special interferential filter. Measurement is carried out by comparison with the primary standards, assigned to Delta Ohm Metrological Laboratory. The probe is designed for **outdoor** readings.

Cosine correction filter and K5 glass dome.

Output, according to the chosen configuration, in μV per $\mu\text{W}/\text{cm}^2$ or 4 ÷ 20mA or 0 ÷ 10Vdc normalized output.

TECHNICAL SPECIFICATIONS

Typical sensitivity:	70 ÷ 200 $\mu\text{V}/(\text{W}/\text{cm}^2)$
Measuring range:	327 ÷ 384nm (1/2) 312 ÷ 393nm (1/10) 305 ÷ 400nm (1/100) Peak: 365nm
Calibration uncertainty:	<6%
f_2 (cosine response):	<6%
f_3 (linearity):	<1%
Operating temperature:	-40°C ÷ +60°C heated version -20°C ÷ +60°C standard version
Impedance:	0.5 ÷ 1.0 K Ω non-normalized version
Version with normalized output 4 ÷ 20mA:	4mA = 0 W/m^2 20mA = 200 W/m^2
Version with standard output 0 ÷ 10Vdc :	0V = 0 W/m^2 10V = 200 W/m^2

Power supply: 10...30Vdc for version with normalized output 4 ÷ 20mA
15...30Vdc for version with normalized output 0 ÷ 10Vdc

Typical spectral response curve LP UVA 03:

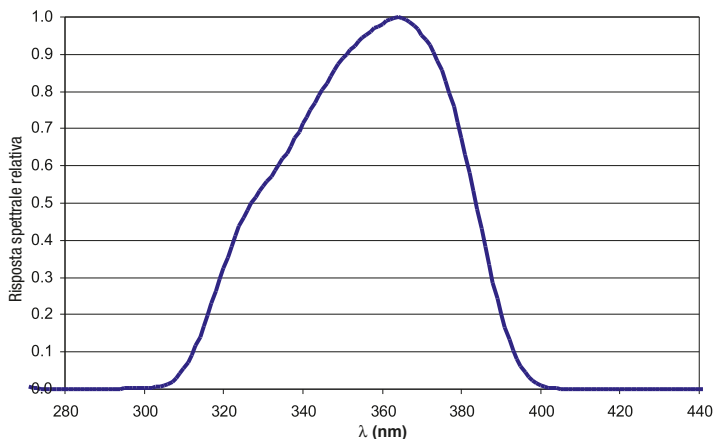

PURCHASING CODE

LP UVA 03: Radiometric probe for the measurement of the UVA irradiance, complete with K5 dome, flying 4-pole connector. **Cable with female connector has to be ordered separately.** Cables: **CPM12 AA** ...with cable length 2, 5 or 10 meters.

LP UVA **03** = μV per $\mu\text{W}/\text{cm}^2$
03BL = μV per $\mu\text{W}/\text{cm}^2$, base with levelling device
03BLAC = μV per $\mu\text{W}/\text{cm}^2$, base with levelling device output 4÷20 mA
03BLAV = μV per $\mu\text{W}/\text{cm}^2$, base with levelling device output 0÷10 mA

CABLE:
CPM12 AA4 **2** = length 2m
5 = length 5m
10 = length 10m

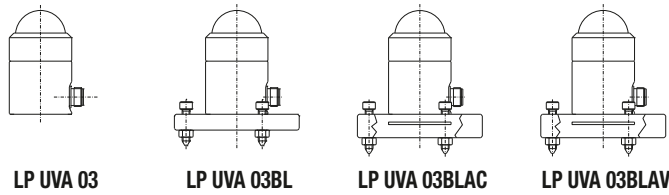

WIRING DIAGRAM
4-pole wire CPM12AA4...

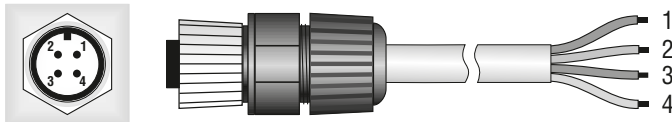

Fixed 4-pole plug M12 Flying 4-pole M12 socket

LP UVA 03, LP UVA 03BL

Connector	Function	Color
1	Positive (+)	Red
2	Negative (-)	Blue
3	Not connected	White
4	Shield	Black

LP UVA 03BLAV

Connector	Function	Color
1	(+) V out	Red
2	(-) Vout and (-) Vdc	Blue
3	(+) Vdc	White
4	Shield	Black

LP UVA 03BLAC

Connector	Function	Color
1	Positive (+)	Red
2	Negative (-)	Blue
3	Not connected	White
4	Shield	Black

LP UVB 03BLAVR:

The LP UVB 03BLAVR probe measures global irradiance (W/m^2) defined as the ratio between the radiant flux (W) passing through a surface and the surface area (m^2) in the UVB (280 nm ÷ 315 nm) spectral region. In particular, the spectral sensitivity is focused at 365nm, with a bandwidth (FWHM) of 5nm.

The global irradiance is the result of the sum of direct solar irradiance and of diffused irradiance

incident on a planar surface. In the UVB spectral region, unlike in the visible portion where the direct component prevails over the direct component, the light is strongly diffused by the atmosphere and thus the two components are equivalent, therefore is very important that the instrument is capable of measuring accurately both the components.

The probe is designed for **outdoor** readings.

Cosine correction filter and Quartz dome.

Standard output 0÷5Vdc.

TECHNICAL SPECIFICATIONS

Typical sensitivity: $\approx 6\text{V}/(\text{W}/\text{m}^2)$
 Typical spectral range: 301nm ÷ 306nm (1/2)
 295 ÷ 308.5nm (1/10)
 290 ÷ 311.5nm (1/100)
 Peak at 304nm
 Calibration uncertainty: <6%
 f_2 (cosine response): <6%
 f_3 (linearity): <1%

Typical spectral response curve **LP 03BLAV**

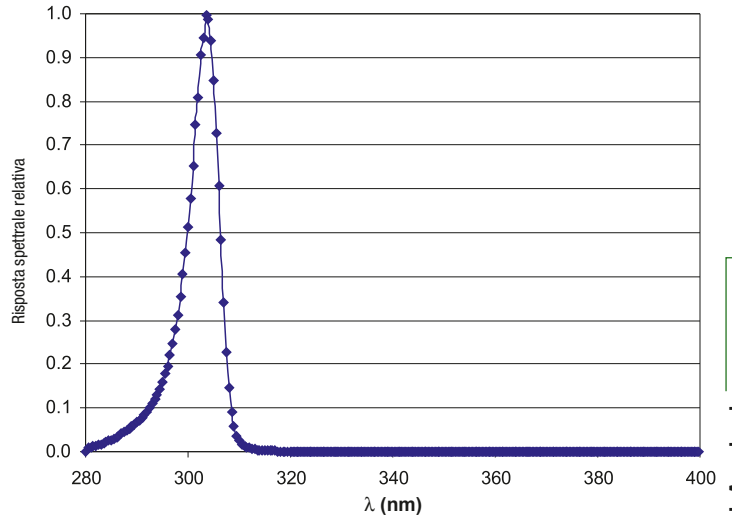

PURCHASING CODE

LP UVB 03BLAVR: Radiometric probe for the measurement of the UVB irradiance, complete with Quartz dome, flying 8-pole connector, calibration report. Cable with female connector has to be ordered separately. Cables: **CPM12 AA8** ..., with cable lengths 2, 5 or 10 meters.

LP UVB **03BLAVR** = 0÷5 V, complete with levelling device and heater

CABLE:
CPM12 AA8 **2** = length 2m
5 = length 5m
10 = length 10m

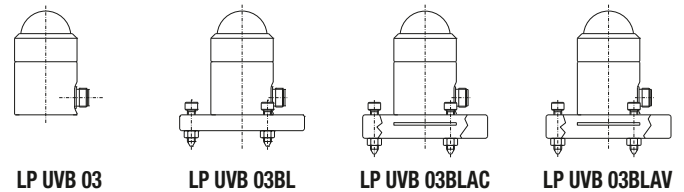

WIRING DIAGRAM
8-pole wire CPM12AA8...

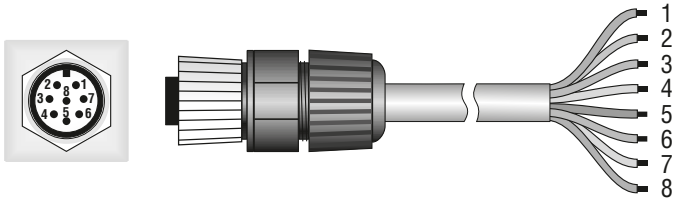

Fixed 8-pole plug M12 Flying 8-pole M12 socket

LP UVB 03BLAVR, LP UVB 03BLAVR

Connector	Function	Color
1	Signal GND	Red
2	V out UV (+)	Blue
3	Not connected	
4	Shield	Braid
5	Power GND	Brown
6	V out Temp. (+)	White
7	Housing	Black
8	Power 7-30Vdc	Green

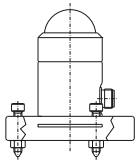

LP UVB 03BLAV

LP UVB 03BLAV CONNECTION DIAGRAMS

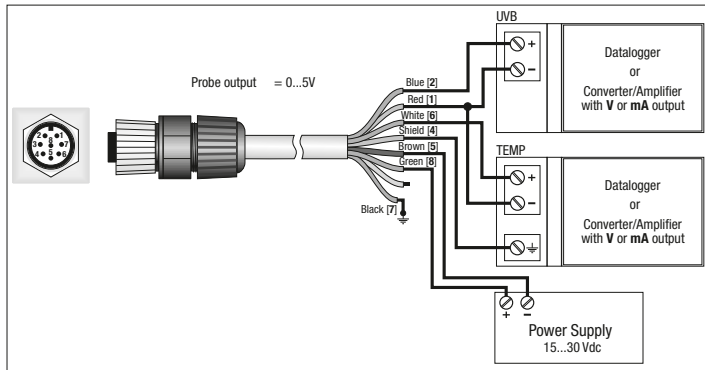

ACCESSORIES

- CPM12 AA8.2:** 8-pole cable. Length 2m. 8-pole M12 connector on one end, open wires on the other side.
- CPM12 AA8.5:** 8-pole cable. Length 5m. 8-pole M12 connector on one end, open wires on the other side.
- CPM12 AA8.10:** 8-pole cable. Length 10m. 8-pole M12 connector on one end, open wires on the other side.

Configurable amplifiers and converters

- HD978TR3:** Configurable signal converter amplifier with 4÷20mA (20÷4mA) output. Input measuring range -10..+60mV. **Default setting 0÷20mV.** Two DIN module (35mm) for rail attachment. Minimum measuring range 2mV. **Configurable with HD 778 TCAL.**
- HD978TR4:** Configurable signal converter amplifier with 0÷10 (10÷0Vdc) output. Input measuring range -10..+60mV. **Default setting 0÷20mV.** Two DIN module (35mm) for rail attachment. Minimum measuring range 2mV. **Configurable with HD 778 TCAL.**
- HD978TR5:** Configurable signal converter amplifier with 4÷20mA (20÷4mA) output. Input measuring range -10..+60mV. **Default setting 0÷20mV.** Minimum measuring range 2mV. **Configurable with HD 778 TCAL. For wall mounting.**
- HD978TR6:** Configurable signal converter amplifier with 0÷10 (10÷0Vdc) output. Input measuring range -10..+60mV. **Default setting 0÷20mV.** Minimum measuring range 2mV. **Configurable with HD 778 TCAL. For wall mounting.**
- HD 778 TCAL:** Power generator in the range -60mv...+60mV, **regulated by PC through RS232C serial port. DeltaLog-7** software to configure type K, J, T and N thermocouple transmitters and HD978TR3, HD978TR4, HD978TR5 and HD974TR6 converters.

LP RAD 03 BLAC



LP RAD 03 BL



LP RAD 03