

# HMP50 Miniature Humidity and Temperature Probe for OEM Applications



*The HMP50 features good measurement performance in a small, rugged and simple probe.*

## Features/Benefits

- Miniature-size humidity transmitter
- Very low power consumption
- Short power-up time
- Measurement range 0 ... 98 %RH and -10 ... +60 °C (+14 ... +140 °F)
- Cable detachable with standard M8 quick connector
- Rugged metal housing
- Interchangeable Vaisala INTERCAP® Sensor
- Optional outputs and cable lengths

The Vaisala INTERCAP® Humidity and Temperature Probe HMP50 is a simple and cost effective humidity transmitter suitable for volume applications or integration into other manufacturers' equipment.

The HMP50 is ideal for a variety of applications such as

- glove boxes
- greenhouses
- fermentation chambers
- data loggers

### Installation flexibility

The probe cable has a screw-on quick connector for ease of installation. Two different cable lengths are available, and customers can also use any M8 series cable of their choice.

### Low current consumption

Because of its very low current consumption and short power-up time, the HMP50 is well suitable for battery-powered applications.

### Several outputs available

The temperature measurement is optional. Three standard voltage outputs are available.

For the RH-only model, a current interface output is available. It can be used to build a 4 ... 20 mA loop-powered current output with external components (the optional current converter kit).

### Rugged design

The aluminum body of the HMP50 is IP65-classified. The sensor is protected by a membrane filter and plastic grid, or optionally a stainless steel filter.

### No need for recalibration

The Vaisala INTERCAP® Sensor is interchangeable. Instead of recalibrating the instrument, the user can easily replace the sensor.

# Technical Data

## Performance

### Relative humidity

Measurement range	0 ... 98 %RH
Typical accuracy at +20 °C (+68 °F)	
0 ... 90 %RH	±3 %RH
90 ... 98 %RH	±5 %RH
Stability	±2 %RH over 2 years
Temperature dependence	

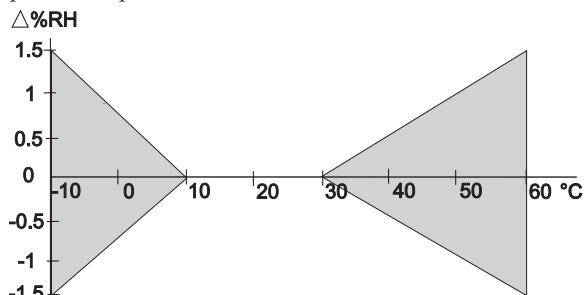

Sensor

Vaisala INTERCAP®

### Temperature (optional)

Measurement range	-10 ... +60 °C (+14 ... +140 °F)
Typical accuracy at +20 °C	±0.6 °C (±1.1 °F)
Accuracy over temperature range	

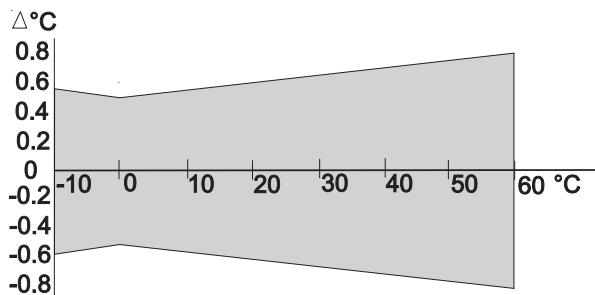

Sensor

Pt 1000 IEC 751 class B

## Operating environment

Environmental temperature	
operating	-10 ... +60 °C (+14 ... +140 °F)
storage	-40 ... +60 °C (-40 ... +140 °F)
Environmental relative humidity	
operating	0 ... 100%RH
Electromagnetic compatibility	Complies with EMC standard EN61326-1, Generic Environment

## Inputs and outputs

Operating voltage	7 ... 28VDC
for 0 ... 5 VDC output model	8 ... 28 VDC
Current consumption	2 mA typical
Settling time at power-up	150 ms
Outputs	0 ... 1 VDC
(equals 0 ... 100% RH	0 ... 2.5 VDC
and	0 ... 5 VDC
-10 ... +60 °C)	
current interface	
External loads	
0 ... 1/0 ... 2.5V	R <sub>L</sub> min 10kohm
0 ... 5	R <sub>L</sub> min 50kohm

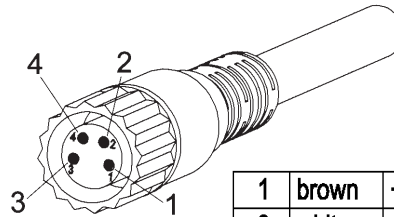

1	brown	+VDC 7... 28 VDC
2	white	+ 0...1/2.5/5 V 0...100 %
3	blue	- VDC
4	black	0...1/2.5/5 V -40...+60 °C

Circuit diagram for 4 ... 20 mA loop-powered current output with current interface.

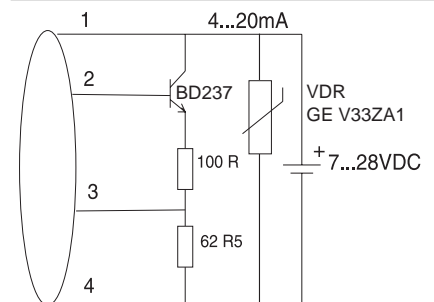

## Mechanics

Materials	
body	chrome coated aluminium
grid/filter	chrome coated ABS plastic
cable	polyurethane
Housing classifications	IP65
Body thread	M12x1 / 10 mm
Grid thread	M11x1 / 5 mm
Cable connector	4-pin M8 (IEC 60947-5-2)
Cable lengths	0.3 and 3 m
Weight	25 g (with 0.3 m cable)

## Options and accessories

Vaisala INTERCAP® sensor	15778HM
Vaisala INTERCAP® sensor with membrane	15872HM
Sensor protection	
plastic grid	DRW010522
membrane filter	DRW010525
stainless steel sintered filter	HM46670SP
Current output converter kit	26182HM
Plastic M12 installation nuts, pair	18350SP
Connection cable M8	
0.3 m	HMP50Z032
3 m	HMP50Z300

## Dimensions

Dimensions in mm (inches)

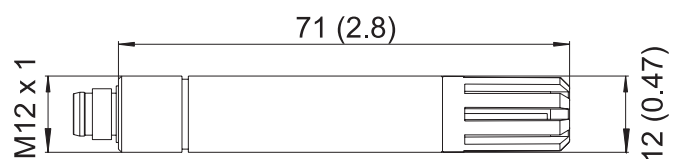

INTERCAP® is a registered trademark of Vaisala.  
Specifications subject to change without prior notice.  
©Vaisala Oyj

